

# magicolor<sup>®</sup> 330

## *Service Manual*

November 2000  
1750049-001B

MINOLTA  
QMS

## **Trademarks**

The following are trademarks or registered trademarks of their respective owners. Other product names mentioned in this manual may also be trademarks or registered trademarks of their respective owners. Registered trademarks are registered in the United States Patent and Trademark Office; some trademarks may also be registered in other countries. QMS, magicolor, and the MINOLTA-QMS logo are registered trademarks of MINOLTA-QMS, Inc. Minolta is a trademark of Minolta Co., Ltd.

## **Copyright Notice**

This manual is Copyrighted © 2000 by MINOLTA-QMS, Inc., One Magnum Pass, Mobile, AL 36618. All Rights Reserved. This manual may not be copied in whole or in part, nor transferred to any other media or language, without the express written permission of MINOLTA-QMS, Inc.

## **Modifications**

Changes or modifications to this equipment not expressly approved by MINOLTA-QMS may void the user's right to operate the equipment.

## **CANADIAN NOTICE**

This digital apparatus does not exceed the Class B limits for radio noise emissions from digital apparatus set out in the Radio interference regulations of the Canadian Department of Communications.

## **AVIS CANADIEN**

Cet appareil numérique est conforme aux limites émission de bruits radioélectriques pour les appareils de classe B stipulés dans le règlement sur le brouillage radioélectrique du Ministère des Communications du Canada.

## **EUROPEAN NOTICE**

This equipment has been tested and determined to be compliant with VDE requirements for a Class B device.

## **HINWEIS**

Hiermit wird bescheinigt, dass der Laserdrucker, in bereinstimmung mit den Bestimmungen der Vfg 104ß 984 funkenstört ist. Der Deutschen Bundespost wurde das Inverkehrbringen dieses Gerätes angezeigt und die Berechtigung zur Überprüfung der Serie auf Einhaltung der Bestimmungen eingeräumt.

# FEDERAL COMMUNICATIONS COMMISSION NOTICE

This equipment has been tested and found to comply with the limits set for a Class B digital device, as stated in Part 15 of the FCC rules. These limits are designed to provide reasonable protection against harmful interference in a commercial installation. This equipment generates, uses, and can radiate radio frequency energy. If not installed and used in accordance with the instructions provided, this equipment may cause disruptive interference to nearby radio and television communications. Even if the equipment is installed according to the instructions, there is no guarantee that interference will not occur in a particular installation. If this equipment does cause disruptive interference to nearby radio and television reception, switch the equipment off to determine if it is the true cause of the interference. If the equipment is the cause of the interference, the user should try to minimize the interference by using one or more of the following actions:

- Either re-orient or relocate the radio/television receiving antenna.
- Increase the separation between the equipment and the radio/television receiver.
- Connect the equipment to an AC outlet that is not on the same circuit as the radio/television receiver.
- If the previous solutions fail to bring results, you should consult either your equipment dealer or an experienced radio/television technician.

For more information on interference, refer to the Federal Communications Commission's booklet "How to Identify and Resolve Radio-TV Interference Problems". This booklet is available from the U.S. Government Printing Office, Washington D.C. 20402, Stock No. 004-000-00345-4.

## CLASS 1 LASER PRODUCT

This Laser Printer is certified to comply with the Class 1 laser product performance standards as set by the U.S. Department of Health and Human Services. This class of laser product has an enclosed laser system that keeps all laser energy safely inside the fully assembled and closed printer.

The laser and output of the laser scanning unit produce a beam that, if viewed, could cause serious eye damage. Service procedures must be followed exactly as written. Use of controls, adjustments, or procedures other than those specified in this manual may result in exposure to hazardous laser radiation.

### Service Section

1. Introduction .....	1-1
2. The FIP Flowchart .....	2-1
3. Primary FIPs: Error Messages .....	3-1
4. Primary FIPs: Printer Performance Problems .....	4-1
5. Primary FIPs: Image Quality Problems .....	5-1
6. Secondary FIPs .....	6-1
7. Getting Connected to Engine Diagnostics .....	7-1
8. Accessing Life Counters from Engine EEPROM .....	8-1
9. Removal and Replacement Procedures .....	9-1
10. Locating P/J Connectors .....	10-1
11. Parts List .....	11-1

### Technical Reference Section

12. Wiring Diagrams and Signal Information .....	12-1
13. Printer Specifications .....	13-1

Blank Page

## Section 1. Introduction

### Symbols Used in This Manual

Various symbols are used throughout this manual to either provide additional information on a specific topic, or to warn of possible danger present during a procedure or action. Be aware of all symbols when they are used, and always read NOTE, CAUTION, and WARNING messages.

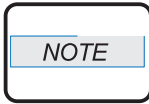

*A Note may indicate an operating or maintenance procedure, practice, or condition that is necessary to accomplish a task efficiently. A Note may also provide additional information that is related to a specific subject or comment on the results achieved through a previous action.*



*A Caution indicates an operating or maintenance procedure, practice, or condition that, if not strictly observed, could result in damage to, or destruction of, equipment.*



**A Warning indicates an operating or maintenance procedure, practice, or condition that, if not strictly observed, could result in injury or loss of life.**

### Tray/Bin Naming Conventions

Within the video interface (Error Messages), service manual, student guide, and engine diagnostics two names will be presented for each tray. Please refer to the table below to avoid confusion in reference to these identifications.

<b>Video Interface (Error Messages)</b>	<b>Diagnostics and Manuals</b>
MPT (Multipurpose Tray)	MSI (Multipurpose Sheet Inserter)
Upper Tray	Tray 1
OPT1 Bin	Tray 2
OPT2 Bin	Tray 3
OPT3 Bin	Tray 4

## Safety information

Follow all safety instructions to prevent accidents while servicing this laser printer. Always be aware of the potential dangers that are present when you are working with electrical or mechanical equipment.

### Power supply and electrical components

Before starting any service procedure, switch off the printer power and unplug the power cord from the wall outlet. If you must service the printer with power applied, be aware of the potential for electrical shock.



**Do not touch any electrified component unless you are instructed to do so by a service procedure.**

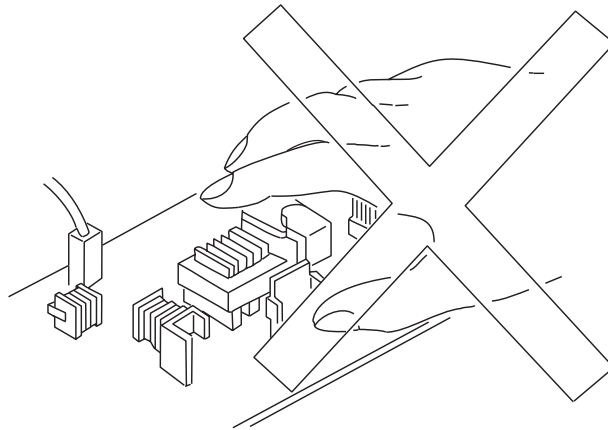

### Mechanical components

Manually rotate drive assemblies to inspect sprockets and gears. Do not try to manually rotate or stop the drive assemblies while any printer motor is running.

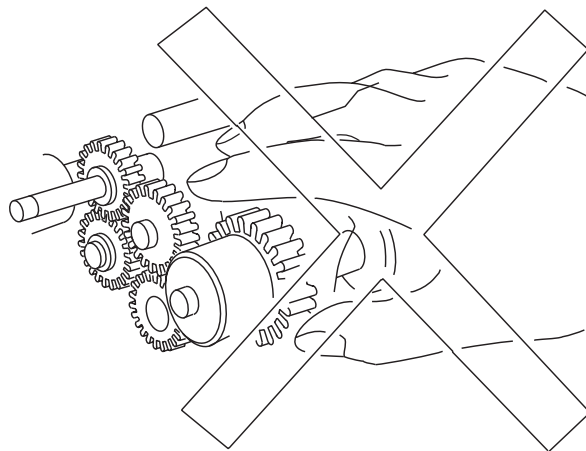



## Laser Components



**This printer generates a laser beam as part of the printing process. The laser beam is a concentrated narrow beam of light that produces extreme heat at its focal point. The laser beam in this printer is invisible. Although you cannot see the beam, it can still cause severe damage. Direct eye exposure to the laser beam may cause eye injury or blindness.**

**Never place a mirror or a reflective tool or object in the laser beam path.**

To avoid permanent eye damage, follow these directions:

- Before starting any service procedure, switch off the printer power and unplug the power cord from the wall outlet.
- Do not disassemble the ROS Assembly or any laser component that displays a Laser Warning Sticker.
- Use caution when you are working around the ROS Assembly or when you are performing laser related troubleshooting or repair procedures.
- Do not disassemble the printer in such a way that the laser beam can exit the print engine during a print cycle.

## Fuser Components

**This printer uses heat to fuse the toner image to a sheet paper. The Fuser Assembly is very hot. Switch off printer power and wait at least 45 minutes for the Fuser to cool before you attempt to service the Fuser Assembly or adjacent components.**



## Safety Components

Make sure interlock switches, covers, and panels are all functioning properly after you have reinstalled or replaced them. If you bypass an interlock switch use extreme caution when working on or around the printer.

## Warning Labels

Throughout the printer, warning labels are displayed on potentially dangerous components. When you service the printer, check to make sure that all warning labels are in place.

Most importantly, **read and obey all posted warning messages.**

**Installation Procedure (FIP) Flowchart and proceed from there.**

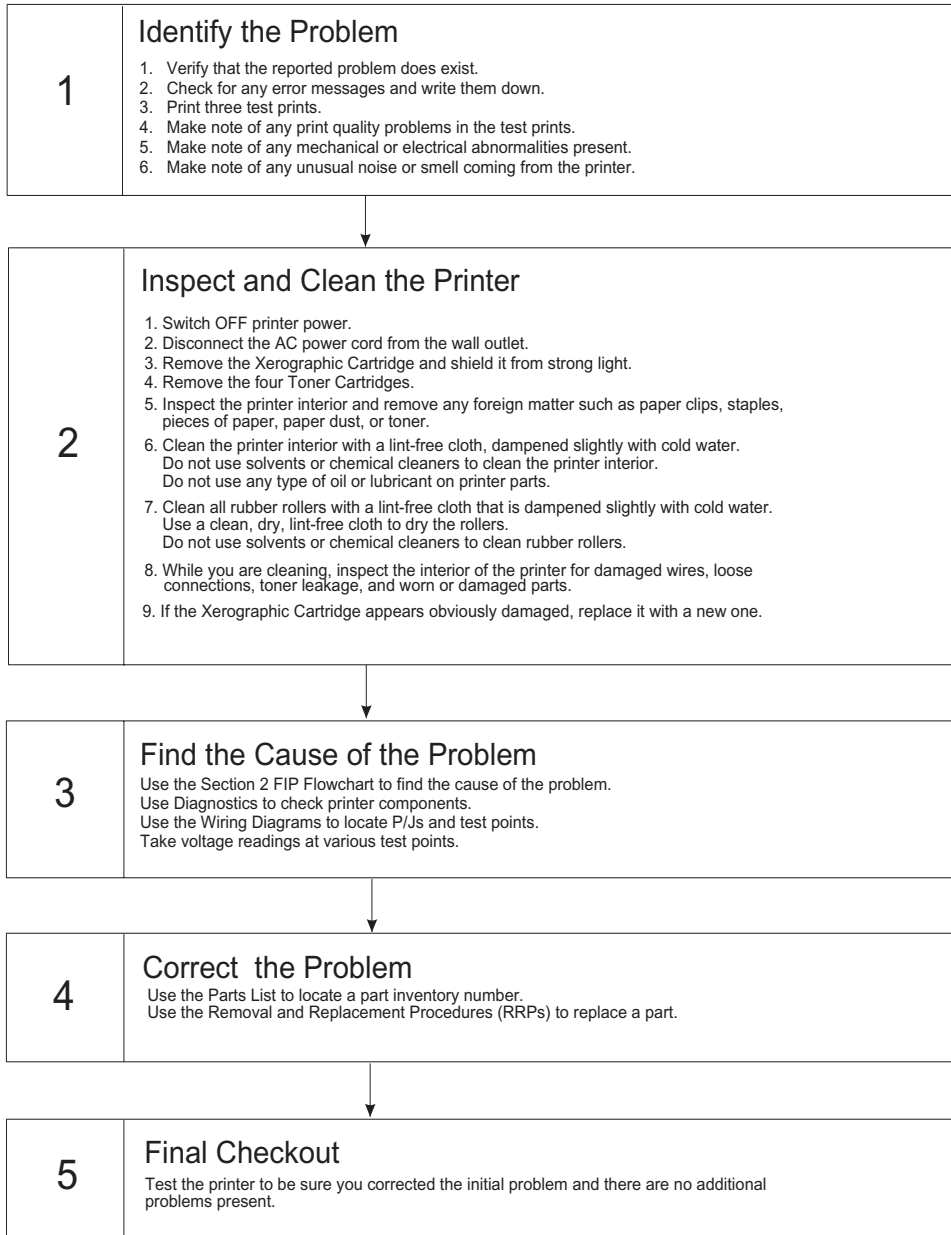

## Section 2. The FIP Flowchart

If you used the Service Flowchart, it should have directed you to this section. Follow the **FIP Flowchart** located at the end of this section to analyze your printer problem.

### How to Use the FIP Flowchart

1. If the printer exhibits an error code, use the FIP Flowchart to locate the correct FIP to resolve the problem.
2. If you a printer operation problem; go to the **PRINTER PERFORMANCE** box.
3. If you have an print image problem; go to the **IMAGE QUALITY** box.
4. Follow the arrow leading from your problem box to the individual Primary FIP (Fault Isolation Procedure) that corresponds to your error code, printer operation problem, or print image problem.
5. Follow the instructions presented in the FIP.
6. If a FIP instructs you to perform a diagnostic test, refer to *Section 7 Getting Connected to Printer Diagnostics*.
7. Voltage and resistance values presented in the FIPs are an approximation. Actual readings may vary from the stated values.
8. Primary FIPs may direct you to a Secondary FIP.
9. Some Steps and substeps are displayed in a ~~strike through~~ font. These steps are not valid nor useful at this time.

### How to Follow a FIP (see the following sample FIP step)

1. Each numbered step in a FIP instructs you to perform a certain action or procedure.
2. The action box may contain additional information and numbered substeps you must follow to perform the action.
3. The action is followed by a question.
4. If your response to the question is **Yes**, then follow the instructions for a Yes reply.
5. If your response to the question is **No**, then follow the instructions for a No reply.
6. FIPs may ask you to take voltage readings at certain test points within the printer. Sections 10 and 13 contain information on test point locations and signal names.
7. FIPs often ask you to replace a printer component. Section 9 Removal and Replacement Procedures provides you detailed steps for removing and replacing all major parts of the printer.

<b>2</b>	<p><b>NO PAPER SENSOR TEST</b></p> <ol style="list-style-type: none"> <li>1. Enter Diagnostics and test Tray 1 No Paper Sensor.</li> <li>2. Slide Tray 1 out of the printer.</li> <li>3. Manually actuate and deactivate Tray 1 No Paper Sensor.</li> </ol> <p><b>Does the Diagnostics Status Window display "actuated" when you manually actuate the sensor?</b></p>	Go to step 3	Replace the No Paper Sensor Assembly (RRP 9.18)
----------	---	--------------	---

- Step number
- Action with substeps, additional information, and a question.
- Action to take if the answer to the question is YES
- Action to take if the answer to the question is NO

## General Notes on Using FIPs

1. FIPs assume there is no malfunction in the printer Controller (ESS). If you are unable to fix a problem using the FIPS, we recommend that you replace the printer Controller.
2. FIPs frequently use new or "known good" components as troubleshooting tools. We recommend you carry a spare Fuser Assembly, MCU PWB, Controller PWB, LVPS, and Xerographic Cartridge.
3. Unless indicated otherwise, the instruction "switch ON printer main power" means for you to switch ON printer power and let the printer proceed through power-on diagnostics and warm-up until it is on-line and ready to print.
4. Conventions used to represent connectors:
  - P/J XX means a Plug and its corresponding Jack are connected.
  - PXX means a Plug is disconnected. (Unless this plug is soldered to a PWB).
  - JXX means a Jack is disconnected. (Unless this jack is soldered to a PWB).
5. When you are instructed to take a voltage reading between "P/J A–B and P/J X–Y", place the red probe (+) of your meter on pin B of P/J A, and place the black probe (–) of your meter on pin Y of P/J X.
6. When you are instructed to take voltage readings between "P/J X and P/J Y" (without specified pin numbers), check all voltage carrying pins. Refer to the Wiring Diagrams for signals and pin numbers.
7. When you are instructed to take a voltage reading, the black probe (–) is generally connected to a pin that is either RTN (Return) or SG (Signal Ground). You can substitute any RTN pin or test point in the printer, and you can use FG (Frame Ground) in place of any SG pin or test point.
8. Unless a FIP instructs you otherwise; before measuring voltages make sure the printer is switched ON, the Xerographic Cartridge and the Paper Cassettes are installed, and all of the interlock switches are actuated.
9. **All voltage values given in the FIPs are approximate values. Actual measured voltages may vary more than 25% from the values stated in the FIPs. The main purpose of most voltage readings taken in the FIPs is to determine whether or not a component is receiving the correct HIGH voltage value from the power supply and if gating (a voltage drop) occurs during component actuation. Gating signals may be nothing more than a pulse, resulting in a momentary drop in voltage that may be difficult or impossible to read on the average multimeter.**
10. FIPs may instruct you to remove or replace a component. Refer to Section 9 Removal and Replacement Procedures for information on how to remove and reinstall a component.
11. When a FIP instructs you to replace a component, and that component is part of a larger assembly, you should replace the entire assembly.

# FIP Flowchart

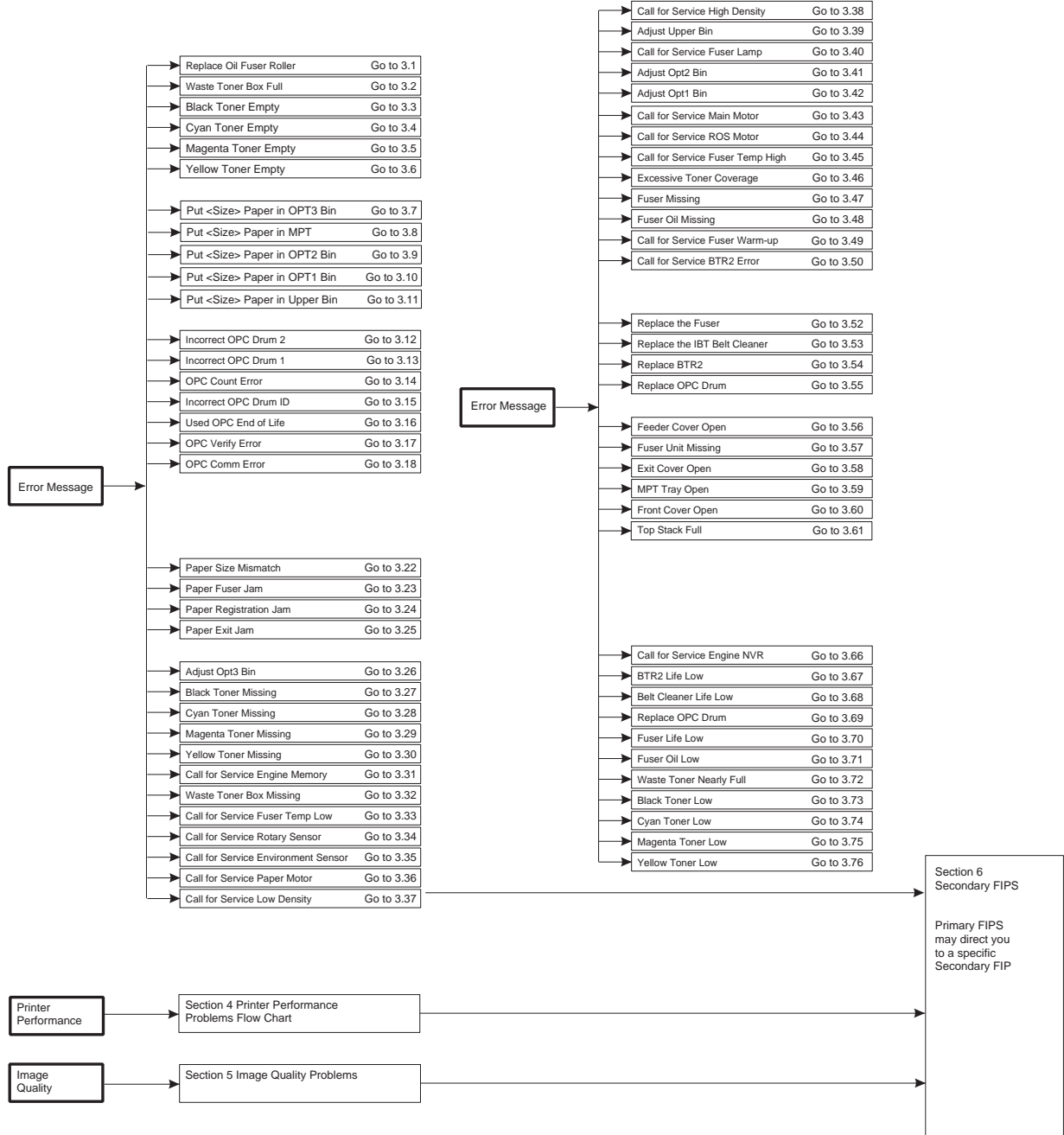

**Section 3 - Primary FIPs: Error Messages****Contents**

3.1 Replace Fuser Oil Roller .....	3-4
3.2 Waste Toner Box Full .....	3-5
3.3 Black Toner Empty .....	3-6
3.4 Cyan Toner Empty .....	3-7
3.5 Magenta Toner Empty .....	3-8
3.6 Yellow Toner Empty .....	3-9
3.7 Put <Size> Paper in OPT3 Bin .....	3-10
3.8 Put <Size> Paper in MPT .....	3-11
3.9 Put <Size> Paper in OPT2 Bin .....	3-12
3.10 Put <Size> Paper in OPT1 Bin .....	3-13
3.11 Put <Size> Paper in Upper Bin .....	3-14
3.12 Incorrect OPC Drum 2 .....	3-15
3.13 Incorrect OPC Drum 1 .....	3-16
3.14 OPC Count Error .....	3-17
3.15 Incorrect OPC Drum ID .....	3-18
3.16 Used OPC End of Life .....	3-20
3.17 OPC Verify Error .....	3-20
3.18 OPC Comm Error .....	3-21
3.22 Paper Size Mismatch .....	3-22
3.23 Paper Fuser Jam .....	3-23
3.24 Paper Registration Jam .....	3-25
3.25 Paper Exit Jam .....	3-27
3.26 Adjust Opt3 Bin .....	3-29
3.27 Black Toner Missing .....	3-30
3.28 Cyan Toner Missing .....	3-31
3.29 Magenta Toner Missing .....	3-32
3.30 Yellow Toner Missing .....	3-33
3.31 Call for Service Engine Memory .....	3-34
3.32 Waste Toner Box Missing .....	3-35
3.33 Call for Service Fuser Temp Low .....	3-36
3.34 Call for Service Rotary Sensor .....	3-37
3.35 Call for Service Environment Sensor .....	3-38
3.36 Call for Service Paper Motor .....	3-39
3.37 Call for Service Low Density .....	3-40
3.38 Call for Service High Density .....	3-42
3.39 Adjust Upper Bin .....	3-44
3.40 Call for Service Fuser Lamp .....	3-45
3.41 Adjust Opt2 Bin .....	3-46
3.42 Adjust Opt1 Bin .....	3-47
3.43 Call for Service Main Motor .....	3-48
3.44 Call for Service ROS Motor .....	3-49
3.45 Call for Service Fuser Temp High .....	3-50

## Primary FIPS: Error Messages

3.46 Excessive Toner Coverage . . . . .	3-51
3.47 Fuser Missing . . . . .	3-52
3.48 Fuser Oil Roll Missing . . . . .	3-53
3.49 Call for Service Fuser Warm-up . . . . .	3-54
3.50 Call for Service BTR2 Error . . . . .	3-55
3.52 Replace the Fuser . . . . .	3-56
3.53 Replace the IBT Belt Cleaner . . . . .	3-57
3.54 Replace BTR2 . . . . .	3-58
3.55 Replace OPC Drum . . . . .	3-59
3.56 Feeder Cover Missing . . . . .	3-60
3.57 Fuser Unit Missing . . . . .	3-61
3.58 Exit Cover Open . . . . .	3-62
3.59 MPT Tray Open . . . . .	3-63
3.60 Front Cover Open . . . . .	3-64
3.61 Top Stack Full . . . . .	3-65
3.66 Call For Service Engine NVR . . . . .	3-66
3.67 BTR2 Life Low . . . . .	3-67
3.68 Belt Cleaner Life Low . . . . .	3-68
3.69 Replace OPC Drum . . . . .	3-69
3.70 Fuser Life Low . . . . .	3-70
3.71 Fuser Oil Low . . . . .	3-71
3.72 Waste Toner Nearly Full . . . . .	3-72
3.73 Black Toner Low . . . . .	3-73
3.74 Cyan Toner Low . . . . .	3-74
3.75 Magenta Toner Low . . . . .	3-75
3.76 Yellow Toner Low . . . . .	3-76



### **3 - Primary FIPs: Error Messages**

#### **Before entering the Error Messages FIPs:**

1. Is the printer plugged into a recommended AC wall outlet?
2. Is the AC power provided at the wall outlet within recommended specifications?
3. Is the AC power cord connected to the printer.
4. Is the AC power cord in good condition; not frayed or broken?
5. Is the printer properly grounded through the AC wall outlet?
6. Is the printer located in an area where the temperature and humidity are moderate and stable?
7. Is the printer located in an area that is free of dust?
8. Is the printer located in an area away from water outlets, steamers, electric heaters, volatile gases, or open flames?
9. Is the printer shielded from the direct rays of the sun?
10. Does the printer have recommended space around all sides for proper ventilation?
11. Is the printer sitting on a level and stable surface?
12. Is recommended paper stock being used in the printer?
13. Does the customer use the printer as instructed in the QMS User Manual?
14. Are consumables replaced at the recommended intervals?
15. Do you have access to QMS Engine Diagnostic menus and do you know how to use them?
16. Are all of the printer assemblies in place and are all of printer covers and doors firmly closed?

### 3.1 - Error Message: Replace Fuser Oil Roller

**The Fuser Oil Roll CRU has reached end of life.**

Logic Control on the MCU PWB detected that the Fuser Oil Roll CRU has processed the equivalent of 20,000 sheets of paper since it was installed.

Step	Actions and Questions	Yes	No
	<p><b>SUSPECT COMPONENTS</b>                      The following components are associated with this specific problem. One or more of these components may have failed partially or completely. If you cannot isolate the problem using this FIP, replace each component listed below, one at a time, until the problem disappears.</p> <ul style="list-style-type: none"> <li>• Wiring and connectors linking the components</li> </ul>		
<b>1</b>	Replace the Oil Roll Assembly with a new one (RRP 9.82)  <b>Does the error message still appear?</b>	Go to step 2	Problem Solved
<b>2</b>	Replace the MCU PWB (RRP 9.123)  <b>Does the error message still appear?</b>	Go to suspect components	Problem Solved

### 3.2 - Error Message: Waste Toner Box Full

**The Waste Toner Box is full.**

Logic control on the MCU PWB detected that the Waste Toner Sensor was on for 1250 print cycles.

Step	Actions and Questions	Yes	No
	<p><b>SUSPECT COMPONENTS</b>                      The following components are associated with this specific problem. One or more of these components may have failed partially or completely. If you cannot isolate the problem using this FIP, replace each component listed below, one at a time, until the problem disappears.</p> <ul style="list-style-type: none"> <li>• Wiring and connectors linking the components</li> <li>• Waste Toner Box auger drive train</li> </ul>		
<b>1</b>	Replace the Waste Toner Box with a new one (RRP 9.49)  <b>Does the error message still appear?</b>	Go to step 2	Problem Solved
<b>2</b>	<p><b>WASTE TONER SENSOR TEST</b></p> <ol style="list-style-type: none"> <li>1. Remove the OPC Drum (RRP 9.48).</li> <li>2. Enter Diagnostics and test the Waste Toner Sensor.</li> <li>3. Manually block the Waste Toner Sensor.</li> </ol> <p><b>In the diagnostics, is "actuated" displayed when you manually block the sensor? And, is "not actuated" displayed when you do not block the sensor?</b></p>	Go to step 3	Replace the Waste Toner Sensor (RRP 9.53)
<b>3</b>	Replace the MCU PWB (RRP 9.123)  <b>Does the error message still appear?</b>	Go to suspect components	Problem Solved

### 3.3 - Error Message: Black Toner Empty

**Black image density is too low.**

Logic control on the MCU PWB detected that the ADC Sensor reads the black patch density as being below specification and that the reading is either slow to raise or does not raise after the printer attempts to increase density.

Step	Actions and Questions	Yes	No
	<p><b>SUSPECT COMPONENTS</b>                      The following components are associated with this specific problem. One or more of these components may have failed partially or completely. If you cannot isolate the problem using this FIP, replace each component listed below, one at a time, until the problem disappears.</p> <ul style="list-style-type: none"> <li>• Black Developer (RRP 9.66)</li> <li>• Black Developer Assembly (RRP 9.65)</li> <li>• LVPS (RRP 9.119)</li> <li>• HVPS (RRP 9.120)</li> <li>• Developer Clutch Assembly (RRP 9.117)</li> </ul>		
<b>1</b>	Replace the Black Toner Cartridge with a new one (RRP 9.58)  <b>Does the error message still appear?</b>	Go to step 2	Problem solved
<b>2</b>	Replace the Dispense Motor (RRP 9.116)  <b>Does the error message still appear?</b>	Go to step 3	Problem solved
<b>3</b>	Replace the ADC Sensor (RRP 9.50)  <b>Does the error message still appear?</b>	Go to step 4	Problem solved
<b>4</b>	Replace the OPC Drum (RRP 9.48)  <b>Does the error message still appear?</b>	Replace the MCU PWB (RRP 9.123)	Problem solved

### 3.4 - Error Message: Cyan Toner Empty

#### Cyan image density is too low.

Logic control on the MCU PWB detected that the ADC Sensor reads the cyan patch density as being below specification and that the reading is either slow to raise or does not raise after the printer attempts to increase density.

Step	Actions and Questions	Yes	No
	<p><b>SUSPECT COMPONENTS</b></p> <p>The following components are associated with this specific problem. One or more of these components may have failed partially or completely. If you cannot isolate the problem using this FIP, replace each component listed below, one at a time, until the problem disappears.</p> <ul style="list-style-type: none"> <li>• Cyan Developer (RRP 9.64)</li> <li>• Cyan Developer Assembly (RRP 9.63)</li> <li>• LVPS (RRP 9.119)</li> <li>• HVPS (RRP 9.120)</li> <li>• Developer Clutch Assembly (RRP 9.117)</li> </ul>		
<b>1</b>	<p>Replace the Cyan Toner Cartridge with a new one (RRP 9.57)</p> <p><b>Does the error message still appear?</b></p>	Go to step 2	Problem solved
<b>2</b>	<p>Replace the Dispense Motor (RRP 9.116)</p> <p><b>Does the error message still appear?</b></p>	Go to step 3	Problem solved
<b>3</b>	<p>Replace the ADC Sensor (RRP 9.50)</p> <p><b>Does the error message still appear?</b></p>	Go to step 4	Problem solved
<b>4</b>	<p>Replace the OPC Drum (RRP 9.48)</p> <p><b>Does the error message still appear?</b></p>	Replace the MCU PWB (RRP 9.123)	Problem solved

### 3.5 - Error Message: Magenta Toner Empty

**Magenta image density is too low.**

Logic control on the MCU PWB detected that the ADC Sensor reads the magenta patch density as being below specification and that the reading is either slow to raise or does not raise after the printer attempts to increase density.

Step	Actions and Questions	Yes	No
	<p><b>SUSPECT COMPONENTS</b>                      The following components are associated with this specific problem. One or more of these components may have failed partially or completely. If you cannot isolate the problem using this FIP, replace each component listed below, one at a time, until the problem disappears.</p> <ul style="list-style-type: none"> <li>• Magenta Developer (RRP 9.62)</li> <li>• Magenta Developer Assembly (RRP 9.61)</li> <li>• LVPS (RRP 9.119)</li> <li>• HVPS (RRP 9.120)</li> <li>• Developer Clutch Assembly (RRP 9.117)</li> </ul>		
<b>1</b>	Replace the Magenta Toner Cartridge with a new one (RRP 9.56)  <b>Does the error message still appear?</b>	Go to step 2	Problem solved
<b>2</b>	Replace the Dispense Motor (RRP 9.116)  <b>Does the error message still appear?</b>	Go to step 3	Problem solved
<b>3</b>	Replace the ADC Sensor (RRP 9.50)  <b>Does the error message still appear?</b>	Go to step 4	Problem solved
<b>4</b>	Replace the OPC Drum (RRP 9.48)  <b>Does the error message still appear?</b>	Replace the MCU PWB (RRP 9.123)	Problem solved

### 3.6 - Error Message: Yellow Toner Empty

#### Yellow image density is too low.

Logic control on the MCU PWB detected that the ADC Sensor reads the yellow patch density as being below specification and that the reading is either slow to raise or does not raise after the printer attempts to increase density.

Step	Actions and Questions	Yes	No
	<p><b>SUSPECT COMPONENTS</b></p> <p>The following components are associated with this specific problem. One or more of these components may have failed partially or completely. If you cannot isolate the problem using this FIP, replace each component listed below, one at a time, until the problem disappears.</p> <ul style="list-style-type: none"> <li>• Yellow Developer (RRP 9.60)</li> <li>• Yellow Developer Assembly (RRP 9.59)</li> <li>• LVPS (RRP 9.119)</li> <li>• HVPS (RRP 9.120)</li> <li>• Developer Clutch Assembly (RRP 9.117)</li> </ul>		
<b>1</b>	<p>Replace the Yellow Toner Cartridge with a new one (RRP 9.55)</p> <p><b>Does the error message still appear?</b></p>	Go to step 2	Problem solved
<b>2</b>	<p>Replace the Dispense Motor (RRP 9.116)</p> <p><b>Does the error message still appear?</b></p>	Go to step 3	Problem solved
<b>3</b>	<p>Replace the ADC Sensor (RRP 9.50)</p> <p><b>Does the error message still appear?</b></p>	Go to step 4	Problem solved
<b>4</b>	<p>Replace the OPC Drum (RRP 9.48)</p> <p><b>Does the error message still appear?</b></p>	Replace the MCU PWB (RRP 9.123)	Problem solved

### 3.7 - Error Message: Put <Size> Paper in OPT3 Bin

#### OPT3 bin tray is out of paper.

Logic control on the MCU PWB detected that the No Paper Sensor in OPT3 Bin is actuated. The Engine Diagnostic Menu may refer to the the OPT3 Bin no paper sensor as Tray 4 no paper sensor.

Step	Actions and Questions	Yes	No
	<p><b>SUSPECT COMPONENTS</b>                      The following components are associated with this specific problem. One or more of these components may have failed partially or completely. If you cannot isolate the problem using this FIP, replace each component listed below, one at a time, until the problem disappears.</p> <ul style="list-style-type: none"> <li>• Wiring and connectors linking the LCIF with the MCU PWB</li> </ul>		
<b>1</b>	<p><b>LCIF TRAY INSPECTION</b>                      Slide OPT3 tray out of the LCIF.</p> <p><b>Is the tray out of paper?</b></p>	Load paper into the tray.	Go to step 2
<b>2</b>	<p><b>NO PAPER SENSOR TEST</b></p> <ol style="list-style-type: none"> <li>1. Enter Diagnostics and test OPT3 Bin/Tray 4 No Paper Sensor.</li> <li>2. Manually actuate and deactivate the No Paper Sensor.</li> </ol> <p><b>Is "actuated" displayed when you manually actuate the sensor? And, is "not actuated" displayed when you manually deactivate the sensor?</b></p>	Go to step 3	Replace OPT3 Bin/Tray 4 No Paper Sensor Assembly (LCIF RRP 6.23)
<b>3</b>	<p>Replace the Feeder PWB (LCIF RRP 6.10)</p> <p><b>Does the error message still appear?</b></p>	Go to step 4	Problem Solved
<b>4</b>	<p>Replace the MCU PWB (RRP 9.123)</p> <p><b>Does the error message still appear?</b></p>	Go to suspect components	Problem Solved



### 3.8 - Error Message: Put <Size> Paper in MPT

#### The Multipurpose Tray is out of paper.

Logic control on the MCU PWB detected that either the Long or the Short Multipurpose No Paper Sensor is actuated.

Step	Actions and Questions	Yes	No
	<p><b>SUSPECT COMPONENTS</b> The following components are associated with this specific problem. One or more of these components may have failed partially or completely. If you cannot isolate the problem using this FIP, replace each component listed below, one at a time, until the problem disappears.</p> <ul style="list-style-type: none"> <li>• Wiring and connectors linking the components</li> </ul>		
<b>1</b>	<p><b>MPT INSPECTION</b> <b>Is the Multipurpose tray out of paper?</b></p>	Load paper into the Tray.	Go to step 2
<b>2</b>	<p><b>MPT LONG NO PAPER SENSOR TEST</b> 1. Enter Diagnostics and test the MPT/MSI Long No Paper Sensor. 2. Manually actuate and deactivate the Long No Paper Sensor. <b>Is "actuated" displayed when you manually actuate the sensor? And, is "not actuated" displayed when you manually deactivate the sensor?</b></p>	Go to step 3	Replace the MPT/MSI Long No Paper Sensor (RRP 9.35)
<b>3</b>	<p><b>MPT/MSI SHORT NO PAPER SENSOR TEST</b> 1. Enter Diagnostics and test the MPT/MSI Short No Paper Sensor. 2. Manually actuate and deactivate the Short No Paper Sensor. <b>Is "actuated" displayed when you manually actuate the sensor? And, is "not actuated" displayed when you manually deactivate the sensor?</b></p>	Go to step 4	Replace the MPT/MSI Short No Paper Sensor (RRP 9.28)
<b>4</b>	<p>Replace the MCU PWB (RRP 9.123) <b>Does the error message still appear?</b></p>	Go to suspect components	Problem Solved

Engine diagnostics may refer to MPT sensors as MSI sensors.

### 3.9 - Error Message: Put <Size> paper in OPT2 Bin

#### OPT2 tray is out of paper.

Logic control on the MCU PWB detected that the No Paper Sensor in OPT2/Tray 3 is actuated. The Engine Diagnostic Menu may refer to the the OPT2 Bin no paper sensor as Tray 3 no paper sensor.

Step	Actions and Questions	Yes	No
	<p><b>SUSPECT COMPONENTS</b>                      The following components are associated with this specific problem. One or more of these components may have failed partially or completely. If you cannot isolate the problem using this FIP, replace each component listed below, one at a time, until the problem disappears.</p> <ul style="list-style-type: none"> <li>• Wiring and connectors linking the LCIF with the MCU PWB</li> </ul>		
<b>1</b>	<p><b>LCIF TRAY INSPECTION</b>                      Slide OPT2 tray out of the LCIF.</p> <p><b>Is the tray out of paper?</b></p>	Load paper into the Tray.	Go to step 2
<b>2</b>	<p><b>NO PAPER SENSOR TEST</b></p> <ol style="list-style-type: none"> <li>1. Enter Diagnostics and test OPT2/Tray 3 No Paper Sensor.</li> <li>2. Manually actuate and deactivate the No Paper Sensor.</li> </ol> <p><b>Is "actuated" displayed when you manually actuate the sensor? And, is "not actuated" displayed when you manually deactivate the sensor?</b></p>	Go to step 3	Replace OPT2/Tray 3 No Paper Sensor Assembly (LCIF RRP 6.23)
<b>3</b>	<p>Replace the Feeder PWB (LCIF RRP 6.10)</p> <p><b>Does the error message still appear?</b></p>	Go to step 4	Problem Solved
<b>4</b>	<p>Replace the MCU PWB (RRP 9.123)</p> <p><b>Does the error message still appear?</b></p>	Go to suspect components	Problem Solved

### 3.10 - Error Message: Put <Size> Paper in OPT1 Bin

#### OPT1 tray is out of paper.

Logic control on the MCU PWB detected that the No Paper Sensor in Tray 2 is actuated. The Engine Diagnostic Menu may refer to the the OPT1 Bin no paper sensor as Tray 2 no paper sensor..

Step	Actions and Questions	Yes	No
	<p><b>SUSPECT COMPONENTS</b></p> <p>The following components are associated with this specific problem. One or more of these components may have failed partially or completely. If you cannot isolate the problem using this FIP, replace each component listed below, one at a time, until the problem disappears.</p> <ul style="list-style-type: none"> <li>• Wiring and connectors linking the LCIF with the MCU PWB</li> </ul>		
<b>1</b>	<p><b>LCIF TRAY INSPECTION</b></p> <p>Slide OPT1 tray out of the LCIF.</p> <p><b>Is the Tray out of paper?</b></p>	Load paper into the Tray.	Go to step 2
<b>2</b>	<p><b>NO PAPER SENSOR TEST</b></p> <ol style="list-style-type: none"> <li>1. Enter Diagnostics and test OPT1/Tray 2 No Paper Sensor.</li> <li>2. Manually actuate and deactivate the No Paper Sensor.</li> </ol> <p><b>Is "actuated" displayed when you manually actuate the sensor? And, is "not actuated" displayed when you manually deactivate the sensor?</b></p>	Go to step 3	Replace OPT1/Tray 2 No Paper Sensor Assembly (LCIF RRP 6.23)
<b>3</b>	<p>Replace the Feeder PWB (LCIF RRP 6.10)</p> <p><b>Does the error message still appear?</b></p>	Go to step 4	Problem Solved
<b>4</b>	<p>Replace the MCU PWB (RRP 9.123)</p> <p><b>Does the error message still appear?</b></p>	Go to suspect components	Problem Solved

### 3.11 - Error Message: Put <Size> Paper in Upper Bin

**The upper tray is out of paper.**

Logic control on the MCU PWB detected that the No Paper Sensor in Upper Tray is actuated. The Engine Diagnostic Menu may refer to the the Upper Bin no paper sensor as Tray 1 no paper sensor..

Step	Actions and Questions	Yes	No
	<p><b>SUSPECT COMPONENTS</b>                      The following components are associated with this specific problem. One or more of these components may have failed partially or completely. If you cannot isolate the problem using this FIP, replace each component listed below, one at a time, until the problem disappears.</p> <ul style="list-style-type: none"> <li>• Wiring and connectors linking the components</li> <li>• Tray 1 Paper Cassette</li> </ul>		
<b>1</b>	<p><b>UPPER TRAY INSPECTION</b>                      Slide Upper tray out of the printer.</p> <p><b>Is the upper tray out of paper?</b></p>	Load paper into the tray.	Go to step 2
<b>2</b>	<p><b>NO PAPER SENSOR TEST</b></p> <ol style="list-style-type: none"> <li>1. Enter Diagnostics and test Upper/Tray 1 No Paper Sensor.</li> <li>2. Slide Upper tray out of the printer.</li> <li>3. Manually actuate and deactivate the Upper Tray No Paper Sensor.</li> </ol> <p><b>Is "actuated" displayed when you manually actuate the sensor? And, is "not actuated" displayed when you manually deactivate the sensor?</b></p>	Go to step 3	Replace the No Paper Sensor Assembly (RRP 9.18)
<b>3</b>	<p>Replace the MCU PWB (RRP 9.123)</p> <p><b>Does the error message still appear?</b></p>	Go to suspect components	Problem Solved

### 3.12 - Error Message: Incorrect OPC Drum 2

#### There is a CRU Memory problem.

Logic control on the MCU PWB detected that the memory initial value of the installed OPC Drum is wrong.

Step	Actions and Questions	Yes	No
	<p><b>SUSPECT COMPONENTS</b> The following components are associated with this specific problem. One or more of these components may have failed partially or completely. If you cannot isolate the problem using this FIP, replace each component listed below, one at a time, until the problem disappears.</p> <ul style="list-style-type: none"> <li>• Wiring and connectors linking the components</li> </ul>		
<b>1</b>	<p><b>OPC DRUM RESEAT &amp; REINITIALIZE</b></p> <ol style="list-style-type: none"> <li>1. Slide the OPC Drum a few inches out of the printer.</li> <li>2. Reinstall and lock the OPC Drum.</li> <li>3. Switch off the printer.</li> <li>4. Wait a minute.</li> <li>5. Switch on the printer.</li> </ol> <p><b>Does the error message still appear?</b></p>	Go to step 2	Problem solved
<b>2</b>	<p>Replace the OPC Drum (RRP 9.48)</p> <p><b>Does the error message still appear?</b></p>	Go to step 3	Problem solved
<b>3</b>	<p><b>MCU PWB INSPECTION</b></p> <ol style="list-style-type: none"> <li>1. Switch off the printer.</li> <li>2. Follow RRP 9.123 to access the MCU PWB.</li> <li>3. Disconnect P/J 16 from the MCU PWB.</li> <li>4. Reconnect P/J 16 to the MCU PWB.</li> <li>5. Switch on the printer.</li> </ol> <p><b>Does the error message still appear?</b></p>	Go to step 4	Problem solved
<b>4</b>	<p>Replace the MCU PWB (RRP 9.123)</p> <p><b>Does the error message still appear?</b></p>	Go to suspect components	Problem Solved

### 3.13 - Error Message: Incorrect OPC Drum 1

**The wrong OPC is installed in the printer.**

Logic control on the MCU PWB detected that the OPC Drum CRUM is incompatible with the printer.

Step	Actions and Questions	Yes	No
	<p><b>SUSPECT COMPONENTS</b>                      The following components are associated with this specific problem. One or more of these components may have failed partially or completely. If you cannot isolate the problem using this FIP, replace each component listed below, one at a time, until the problem disappears.</p> <ul style="list-style-type: none"> <li>• Wiring and connectors linking the components</li> </ul>		
<b>1</b>	<p>Replace the OPC Drum (RRP 9.48) with a cartridge that is recommended for use with this printer.</p> <p><b>Does the error message still appear?</b></p>	Go to step 2	Problem solved
<b>2</b>	<p><b>MCU PWB INSPECTION</b></p> <ol style="list-style-type: none"> <li>1. Switch off the printer.</li> <li>2. Follow RRP 9.123 to access the MCU PWB.</li> <li>3. Disconnect P/J 16 from the MCU PWB.</li> <li>4. Reconnect P/J 16 to the MCU PWB.</li> <li>5. Switch on the printer.</li> </ol> <p><b>Does the error message still appear?</b></p>	Go to step 3	Problem solved
<b>3</b>	<p>Replace the MCU PWB (RRP 9.123)</p> <p><b>Does the error message still appear?</b></p>	Go to suspect components	Problem Solved

### 3.14 - Error Message: OPC Count Error

**There is a OPC Memory problem.**

Logic control on the MCU PWB could not read the CRUM counter value.

Step	Actions and Questions	Yes	No
	<p><b>SUSPECT COMPONENTS</b>            The following components are associated with this specific problem. One or more of these components may have failed partially or completely. If you cannot isolate the problem using this FIP, replace each component listed below, one at a time, until the problem disappears.</p> <ul style="list-style-type: none"> <li>• Wiring and connectors linking the components</li> </ul>		
<b>1</b>	<p><b>OPC DRUM RESEAT</b></p> <ol style="list-style-type: none"> <li>1. Slide the OPC Drum a few inches out of the printer.</li> <li>2. Reinstall and lock the OPC Drum.</li> </ol> <p><b>Does the error message still appear?</b></p>	Go to step 2	Problem solved
<b>2</b>	<p><b>MCU PWB INSPECTION</b></p> <ol style="list-style-type: none"> <li>1. Switch off the printer.</li> <li>2. Follow RRP 9.123 to access the MCU PWB.</li> <li>3. Disconnect P/J 16 from the MCU PWB.</li> <li>4. Reconnect P/J 16 to the MCU PWB.</li> <li>5. Switch on the printer.</li> </ol> <p><b>Does the error message still appear?</b></p>	Go to step 3	Problem solved
<b>3</b>	<p>Replace the OPC Drum (RRP 9.48) with a Cartridge that is recommended for use with this printer.</p> <p><b>Does the error message still appear?</b></p>	Problem solved	Go to step 4
<b>4</b>	<p>Replace the MCU PWB (RRP 9.123)</p> <p><b>Does the error message still appear?</b></p>	Go to suspect components	Problem Solved

### 3.15 - Error Message: Incorrect OPC Drum ID

**The wrong OPC Drum is installed in the printer.**

Logic control on the MCU PWB detected that the installed OPC Drum is incompatible with the printer.

Step	Actions and Questions	Yes	No
	<p><b>SUSPECT COMPONENTS</b>                      The following components are associated with this specific problem. One or more of these components may have failed partially or completely. If you cannot isolate the problem using this FIP, replace each component listed below, one at a time, until the problem disappears.</p> <ul style="list-style-type: none"> <li>• Wiring and connectors linking the components</li> </ul>		
<b>1</b>	<p>Replace the OPC Drum (RRP 9.48) with a Cartridge that is recommended for use with this printer.</p> <p><b>Does the error message still appear?</b></p>	Go to step 2	Problem solved
<b>2</b>	<p><b>MCU PWB INSPECTION</b></p> <ol style="list-style-type: none"> <li>1. Switch off the printer.</li> <li>2. Follow RRP 9.123 to access the MCU PWB.</li> <li>3. Disconnect P/J 16 from the MCU PWB.</li> <li>4. Reconnect P/J 16 to the MCU PWB.</li> <li>5. Switch on the printer.</li> </ol> <p><b>Does the error message still appear?</b></p>	Go to step 3	Problem solved
<b>3</b>	<p>Replace the MCU PWB (RRP 9.123)</p> <p><b>Does the error message still appear?</b></p>	Go to suspect components	Problem Solved



### 3.16 - Error Message: Used OPC End of Life

#### The OPC Drum installed is not new.

Logic control on the MCU PWB detected that the installed OPC Drum is not new.

Step	Actions and Questions	Yes	No
	<p><b>SUSPECT COMPONENTS</b>            The following components are associated with this specific problem. One or more of these components may have failed partially or completely. If you cannot isolate the problem using this FIP, replace each component listed below, one at a time, until the problem disappears.</p> <ul style="list-style-type: none"> <li>• Wiring and connectors linking the components</li> </ul>		
<b>1</b>	Replace the OPC Drum (RRP 9.48) with a Cartridge that is recommended for use with this printer.  <b>Does the error message still appear?</b>	Go to step 2	Problem solved
<b>2</b>	<p><b>MCU PWB INSPECTION</b></p> <ol style="list-style-type: none"> <li>1. Switch off the printer.</li> <li>2. Follow RRP 9.123 to access the MCU PWB.</li> <li>3. Disconnect P/J 16 from the MCU PWB.</li> <li>4. Reconnect P/J 16 to the MCU PWB.</li> <li>5. Switch on the printer.</li> </ol> <b>Does the error message still appear?</b>	Go to step 3	Problem solved
<b>3</b>	Replace the MCU PWB (RRP 9.123)  <b>Does the error message still appear?</b>	Go to suspect components	Problem Solved

### 3.17 - Error Message: OPC Verify Error

**There is a CRU Memory problem.**

Logic control on the MCU PWB detected that the data read from CRUM was not the same data written to CRUM.

Step	Actions and Questions	Yes	No
	<p><b>SUSPECT COMPONENTS</b>                      The following components are associated with this specific problem. One or more of these components may have failed partially or completely. If you cannot isolate the problem using this FIP, replace each component listed below, one at a time, until the problem disappears.</p> <ul style="list-style-type: none"> <li>• Wiring and connectors linking the components</li> </ul>		
<b>1</b>	<p><b>OPC DRUM RESEAT</b></p> <ol style="list-style-type: none"> <li>1. Slide the OPC Drum a few inches out of the printer.</li> <li>2. Reinstall and lock the OPC Drum.</li> </ol> <p><b>Does the error message still appear?</b></p>	Go to step 2	Problem solved
<b>2</b>	<p><b>MCU PWB INSPECTION</b></p> <ol style="list-style-type: none"> <li>1. Switch off the printer.</li> <li>2. Follow RRP 9.123 to access the MCU PWB.</li> <li>3. Disconnect P/J 16 from the MCU PWB.</li> <li>4. Reconnect P/J 16 to the MCU PWB.</li> <li>5. Switch on the printer.</li> </ol> <p><b>Does the error message still appear?</b></p>	Go to step 3	Problem solved
<b>3</b>	<p>Replace the OPC Drum (RRP 9.48) with a Cartridge that is recommended for use with this printer.</p> <p><b>Does the error message still appear?</b></p>	Problem solved	Go to step 4
<b>4</b>	<p>Replace the MCU PWB (RRP 9.123)</p> <p><b>Does the error message still appear?</b></p>	Go to suspect components	Problem Solved

### 3.18 - Error Message: OPC Comm Error

**There is a CRU Memory problem.**

Logic control on the MCU PWB could not read from or write to the CRUM.

Step	Actions and Questions	Yes	No
	<p><b>SUSPECT COMPONENTS</b>            The following components are associated with this specific problem. One or more of these components may have failed partially or completely. If you cannot isolate the problem using this FIP, replace each component listed below, one at a time, until the problem disappears.</p> <ul style="list-style-type: none"> <li>• Wiring and connectors linking the components</li> </ul>		
<b>1</b>	<p><b>OPC DRUM RESEAT</b>            1. Slide the OPC Drum a few inches out of the printer.            2. Reinstall and lock the OPC Drum.  <b>Does the error message still appear?</b></p>	Go to step 2	Problem solved
<b>2</b>	<p>Replace the OPC Drum (RRP 9.48)  <b>Does the error message still appear?</b></p>	Problem solved	Go to step 3
<b>3</b>	<p>Replace the MCU PWB (RRP 9.123)  <b>Does the error message still appear?</b></p>	Go to suspect components	Problem Solved

### 3.22 - Error Message: Paper Size Mismatch

**There is a problem with paper size settings.**

Logic control on the MCU PWB detected that the paper that was fed into the printer was not the same size that was detected by the Size Sensors. The Registration Sensor actuation/deactuation monitors the size of the paper as it travels along the paper path.

Step	Actions and Questions	Yes	No
	<p><b>SUSPECT COMPONENTS</b>                      The following components are associated with this specific problem. One or more of these components may have failed partially or completely. If you cannot isolate the problem using this FIP, replace each component listed below, one at a time, until the problem disappears.</p> <ul style="list-style-type: none"> <li>• Wiring and connectors linking the components</li> </ul>		
<b>1</b>	<p><b>PAPER TRAY INSPECTION</b>                      1. Open the Paper Tray.                      2. Inspect the paper guides.  <b>Are the paper guides adjusted for the size of paper loaded in the tray?</b></p>	Go to step 2	Adjust the paper guides
<b>2</b>	<p><b>SIZE SENSOR ACTUATOR INSPECTION</b>                      1. With the Paper Tray out of the printer, inspect the Size Actuators that are located at the rear of the Tray.                      2. Slide the paper guides in and out while watching the action of the Actuators.  <b>Are the Size Actuators undamaged and do they move freely as you slide the paper guides in and out?</b></p>	Go to step 3	Replace the Paper Tray.
<b>3</b>	<p>Replace the Size Switch Assembly (RRP 9.17)  <b>Does the error message still appear?</b></p>	Go to step 4	Problem Solved
<b>4</b>	<p>Replace the MCU PWB (RRP 9.123)  <b>Does the error message still appear?</b></p>	Go to suspect components	Problem Solved

### 3.23 - Error Message: Paper Jam Fuser

#### There is problem near the Fuser Exit Sensor.

Logic control on the MCU PWB detected that the Fuser Exit Sensor did not actuate within the specified time after the Fuser Entrance Sensor was actuated.

Step	Actions and Questions	Yes	No
	<p><b>SUSPECT COMPONENTS</b> The following components are associated with this specific problem. One or more of these components may have failed partially or completely. If you cannot isolate the problem using this FIP, replace each component listed below, one at a time, until the problem disappears.</p>		
<b>1</b>	<p><b>PAPER PATH INSPECTION</b></p> <ol style="list-style-type: none"> <li>Slide the Fuser Assembly out of the printer and remove the Oil Roll Assembly.</li> <li>Inspect the lead edge of the jammed sheet of paper.</li> </ol> <p><b>Is the lead edge of the sheet of paper actuating the Fuser Exit Sensor?</b></p>	Go to step 2	Go to step 4
<b>2</b>	<p><b>FUSER EXIT SENSOR TEST</b></p> <ol style="list-style-type: none"> <li>Enter Diagnostics and test the Fuser Exit Sensor.</li> <li>Read the test result in the Diagnostics Status Window.</li> <li>Slide the Fuser Assembly out of the printer.</li> <li>Use a piece of tape to hold down the Fuser Exit Sensor Actuator.</li> <li>Slide the Fuser Assembly into the printer.</li> <li>Rerun and read the test result in the Diagnostics Status Window.</li> </ol> <p><b>Did the test result in the Diagnostics Status Window change from "not actuated" to "actuated" after you performed step 4 above?</b></p>	Go to step 3	Replace the Fuser Exit Sensor (RRP 9.89)
<b>3</b>	<p>Replace the MCU PWB (RRP 9.123)</p> <p><b>Does the error message still appear?</b></p>	Go to suspect components	Problem solved
<b>4</b>	<p><b>PAPER PATH INSPECTION</b></p> <p>Inspect the lead edge of the jammed sheet of paper.</p> <p><b>Did the lead edge of the sheet of paper enter the Fuser Rolls?</b></p>	Go to step 5	Go to step 9
<b>5</b>	<p><b>PAPER INSPECTION</b></p> <p>Inspect the jammed sheet of paper.</p> <p><b>Is the paper wrapped around the Fuser Rolls?</b></p>	Remove the paper and install a new Oil Roll Assembly (RRP 9.82)	Go to step 6

### 3.23 - Error Message: Paper Jam Fuser, continued

Step	Actions and Questions	Yes	No
6	<p><b>PAPER INSPECTION</b> Inspect the jammed sheet of paper.</p> <p><b>Is the paper damaged from or caught on the Stripper Fingers that are located at the exit of the Fuser Rolls?</b></p>	Replace the Main Fuser Assembly (RRP 9.81)	Go to step 7
7	<p><b>PAPER INSPECTION</b> Inspect the jammed sheet of paper.</p> <p><b>Is the paper damaged or accordion folded at the entrance to the Fuser Rolls?</b></p>	Go to step 8	Go to suspect components
8	<p><b>FUSER COVER FAN INSPECTION</b> Inspect the Fuser Cover Fan.</p> <p><b>Is the Fan rotating?</b></p>	Go to step 9	Replace Fuser Chute Fan (RRP 9.131)
9	<p><b>FUSER DRIVE INSPECTION</b></p> <ol style="list-style-type: none"> <li>1. Remove the Fuser Assembly from the printer.</li> <li>2. Inspect the FT1 Input Gear (PL9.4.15) that is located near the Heat Rod AC plug at the rear of the Assembly.</li> </ol> <p><b>Is the gear undamaged?</b></p>	Go to step 10	Replace the Main Fuser Assembly (RRP 9.81)
10	<p><b>FUSER DRIVE CHECK</b></p> <ol style="list-style-type: none"> <li>1. Remove the Fuser Assembly from the printer.</li> <li>2. Hand rotate the FT1 Input Gear (PL9.4.15) that is located near the Heat Rod AC plug at the rear of the Assembly (The Gear should provide a good deal of resistance to hand rotating)</li> </ol> <p><b>Does the gear turn, and do the Fuser Heat Roll and Pressure Roll also rotate.?</b></p>	Go to step 11	Replace the Main Fuser Assembly (RRP 9.81)
11	<p><b>FUSER DRIVE ASSEMBLY INSPECTION</b></p> <ol style="list-style-type: none"> <li>1. Remove the Fuser Assembly from the printer.</li> <li>2. Look inside the empty Fuser cavity.</li> <li>3. Inspect the drive gear at the rear of the cavity.</li> </ol> <p><b>Is the gear undamaged?</b></p>	Go to step 12	Replace the Fuser Drive Assembly (RRP 9.110)
12	<p><b>PAPER HANDLING MOTOR TEST</b> Enter Diagnostics and test the Paper Handling Motor.</p> <p><b>Does the Paper Handling Motor rotate when you run the Paper Handling Motor Test?</b></p>	Go to suspect components	Replace the Paper Handling Motor Assembly (RRP 9.111)

### 3.24 - Error Message: Paper Jam Registration

#### There is a problem near the Registration Sensor.

Logic control on the MCU PWB detected that the Registration Sensor did not actuate within the specified time after paper feed.

Step	Actions and Questions	Yes	No
	<p><b>SUSPECT COMPONENTS</b> The following components are associated with this specific problem. One or more of these components may have failed partially or completely. If you cannot isolate the problem using this FIP, replace each component listed below, one at a time, until the problem disappears.</p> <ul style="list-style-type: none"> <li>• Wiring and connectors linking the components</li> <li>• Main Paper Handling Assembly (RRP 9.36)</li> <li>• Interlock switches and circuits</li> </ul>		
<b>1</b>	<p><b>PAPER PATH INSPECTION</b></p> <ol style="list-style-type: none"> <li>1. Slide the Registration Transport out of the printer.</li> <li>2. Inspect the lead edge of the jammed sheet of paper.</li> </ol> <p><b>Is the sheet of paper covering the Registration Sensor?</b></p>	Go to step 2	Go to step 3
<b>2</b>	<p><b>REGISTRATION SENSOR TEST</b></p> <ol style="list-style-type: none"> <li>1. Enter Diagnostics and test the Registration Sensor.</li> <li>2. Read the test result in the Diagnostics Status Window.</li> <li>3. Slide the Registration Transport out of the printer.</li> <li>4. Place a piece of tape over the Registration Sensor.</li> <li>5. Slide the Registration Transport into the printer.</li> <li>6. Read the test result in the Diagnostics Status Window.</li> </ol> <p><b>Did the test result in the Diagnostics Status Window change from "not actuated" to "actuated"?</b></p>	Replace the MCU PWB (RRP 9.123)	Replace the Registration Sensor (RRP 9.45)
<b>3</b>	<p><b>PAPER PATH INSPECTION</b></p> <ol style="list-style-type: none"> <li>1. Slide the Registration Transport out of the printer.</li> <li>2. Inspect the lead edge of the jammed sheet of paper.</li> </ol> <p><b>Did the Tray 1 Feed Rolls drive the sheet of paper into the Turn Rolls?</b></p>	Go to step 7	Go to step 4
<b>4</b>	<p><b>PAPER HANDLING MOTOR TEST</b></p> <p>Enter Diagnostics and test the Paper Handling Motor.</p> <p><b>Does the Paper Handling Motor rotate when you run the Paper Handling Motor Test?</b></p>	Go to step 6	Go to step 5
<b>5</b>	<p>Replace the MCU PWB (RRP 9.123)</p> <p><b>Does the error message still appear?</b></p>	Replace the Paper Handling Motor Assembly (RRP 9.111)	Problem solved

### 3.24 - Error Message: Paper Jam Registration, continued

Step	Actions and Questions	Yes	No
<p><b>6</b></p>	<p><b>UPPER TRAY FEED SOLENOID TEST</b>                      Enter Diagnostics and test the Upper/Tray 1 Feed Solenoid. The Engine Diagnostic Menu may refer to the the Upper Tray as Tray 1.</p> <p><b>Does the Upper/Tray 1 Feed Solenoid actuate when you run the test?</b></p>	<p>Replace the Upper/Tray 1 Feed Solenoid (RRP 9.15)</p>	<p>Replace Upper/Tray 1 Feed Rolls (RRP 9.14)</p>
<p><b>7</b></p>	<p><b>PAPER PATH INSPECTION</b></p> <ol style="list-style-type: none"> <li>1. Slide the Registration Transport out of the printer.</li> <li>2. Inspect the lead edge of the jammed sheet of paper.</li> </ol> <p><b>Did the Turn Rolls drive the sheet of paper into the Pre-Registration Rolls?</b></p>	<p>Go to step 8</p>	<p>Replace the Turn Roll Assembly (RRP 9.16)</p>
<p><b>8</b></p>	<p><b>PRE-REGISTRATION ROLL TEST</b></p> <ol style="list-style-type: none"> <li>1. Slide the Registration Transport out of the printer.</li> <li>2. Slide a piece of paper between the Pre-Registration Rolls.</li> <li>3. Turn the green knob that is attached to the end of the Pre-Registration Rolls.</li> </ol> <p><b>Do the Pre-Registration Rolls drive the sheet of paper into the Registration Sensor?</b></p>	<p>Replace the Pre-Registration Clutch (RRP 9.41)</p>	<p>Replace the Pre-Registration Roll Assembly (RRP 9.40)</p>



### 3.25 - Error Message: Paper Jam Exit

#### There is a problem near the Top Exit Sensor.

Logic control on the MCU PWB detected that the Top Exit Sensor did not actuate within the specified time after the Fuser Exit Sensor actuated.

Step	Actions and Questions	Yes	No
	<p><b>SUSPECT COMPONENTS</b> The following components are associated with this specific problem. One or more of these components may have failed partially or completely. If you cannot isolate the problem using this FIP, replace each component listed below, one at a time, until the problem disappears.</p> <ul style="list-style-type: none"> <li>• Wiring and connectors linking the components</li> <li>• Fuser Assembly (RRP 9.80)</li> <li>• Interlock switches and circuits</li> </ul>		
<b>1</b>	<p><b>PAPER PATH INSPECTION</b></p> <ol style="list-style-type: none"> <li>1. Open the Exit Cover.</li> <li>2. Inspect the lead edge of the jammed sheet of paper.</li> </ol> <p><b>Is the sheet of paper actuating the Top Exit Sensor?</b></p>	Go to step 2	Go to step 4
<b>2</b>	<p><b>TOP EXIT SENSOR TEST</b></p> <ol style="list-style-type: none"> <li>1. Enter Diagnostics and test the Exit Chute Interlock.</li> <li>2. Read the test result in the Diagnostics Status Window.</li> <li>3. Open the Exit Cover.</li> <li>4. Actuate the Exit Cover Interlock Switch in the Diagnostics.</li> <li>5. Manually actuate the Top Exit Sensor.</li> <li>6. Read the test result in the Diagnostics Status Window.</li> </ol> <p><b>Did the test result in the Diagnostics Status Window change from "actuated" to "not actuated"?</b></p>	Go to step 3	Replace the Top Exit Sensor (RRP 9.106)
<b>3</b>	<p>Replace the MCU PWB (RRP 9.123)</p> <p><b>Does the error message still appear?</b></p>	Go to suspect components	Problem solved
<b>4</b>	<p><b>PAPER HANDLING MOTOR TEST</b></p> <p>Enter Diagnostics and test the Paper Handling Motor.</p> <p><b>Does the Paper Handling Motor rotate when you run the test?</b></p>	Go to step 6	Go to step 5
<b>5</b>	<p>Replace the Paper Handling Motor Assembly (RRP 9.111)</p> <p><b>Does the error message still appear?</b></p>	Replace the MCU PWB (RRP 9.123)	Problem solved

**3.25 - Error Message: Exit Jam, continued**

Step	Actions and Questions	Yes	No
<p><b>6</b></p>	<p><b>FUSER DRIVE ASSEMBLY OBSERVATION</b>                      1. Enter Diagnostics and test the Paper Handling Motor.                      2. Observe the Fuser Drive Assembly.  <b>Do the Gears of the Fuser Drive Assembly rotate smoothly?</b></p>	<p>Go to step 7</p>	<p>Replace the Fuser Drive Assembly (RRP 9.110)</p>
<p><b>7</b></p>	<p><b>EXIT ROLL OBSERVATION</b>                      1. Open the Exit Cover.                      2. Actuate the Exit Cover Interlock Switch.                      3. Enter Diagnostics and test the Paper Handling Motor.                      4. Observe the Exit Rolls  <b>Do all of the Exit Rolls rotate smoothly?</b></p>	<p>Go to suspect components</p>	<p>Replace the Lower Exit Assembly (RRP 9.101)</p>

### 3.26 - Error Message: Adjust OPT3 Bin

#### There is a problem with the OPT3 tray or bin.

Logic control on the MCU PWB did not detect a paper tray installed in the OPT3 bin. Note: the Engine Diagnostic Menu may refer to the the OPT3 Bin no paper sensor as Tray 4.

Step	Actions and Questions	Yes	No
	<p><b>SUSPECT COMPONENTS</b> The following components are associated with this specific problem. One or more of these components may have failed partially or completely. If you cannot isolate the problem using this FIP, replace each component listed below, one at a time, until the problem disappears.</p> <ul style="list-style-type: none"> <li>• Wiring and connectors linking the LCIF to the Base Engine</li> <li>• Wiring and connectors linking the components</li> </ul>		
<b>1</b>	<p><b>PAPER TRAY INSPECTION</b> 1. Remove the paper tray from OPT3 bin. 2. Inspect the Size Actuators at the rear of the Tray. <b>Are the Actuators intact and free of damage?</b></p>	Go to step 2	Replace the Paper Tray.
<b>2</b>	<p>Replace the OPT3 Bin Switch Assembly (LCIF RRP 6.13) <b>Does the error message still appear?</b></p>	Go to step 3	Problem solved
<b>3</b>	<p>Replace the Feeder PWB (LCIF RRP 6.10) <b>Does the error message still appear?</b></p>	Go to step 4	Problem solved
<b>4</b>	<p>Replace the MCU PWB (RRP 9.123) <b>Does the error message still appear?</b></p>	Go to suspect components	Problem solved

### 3.27 - Error Message: Black Toner Missing

**The Black Toner Cartridge is either not installed or not installed correctly.**

Logic control on the MCU PWB did not receive a signal from the Cartridge Sensor when the Rotary Frame moved the Black Developer Housing into position.

Step	Actions and Questions	Yes	No
	<p><b>SUSPECT COMPONENTS</b>                      The following components are associated with this specific problem. One or more of these components may have failed partially or completely. If you cannot isolate the problem using this FIP, replace each component listed below, one at a time, until the problem disappears.</p> <ul style="list-style-type: none"> <li>• Wiring and connectors linking the components</li> <li>• Rotary Frame Assembly (RRP 9.67)</li> </ul>		
<b>1</b>	<p><b>BLACK TONER CARTRIDGE RESEAT</b>                      1. Remove the Black Toner Cartridge.                      2. Reinstall the Black Toner Cartridge.  <b>Does the error message still appear?</b></p>	Go to step 2	Treat as an intermittent problem.
<b>2</b>	<p>Replace the Black Toner Cartridge (RRP 9.58)  <b>Does the error message still appear?</b></p>	Go to step 3	Problem solved
<b>3</b>	<p>Replace the Toner Cartridge Sensor (RRP 9.69)  <b>Does the error message still appear?</b></p>	Go to step 4	Problem solved
<b>4</b>	<p>Replace the MCU PWB (RRP 9.123)  <b>Does the error message still appear?</b></p>	Go to suspect components	Problem solved

### 3.28 - Error Message: Cyan Toner Missing

**The Cyan Toner Cartridge is either not installed or not installed correctly.**

Logic control on the MCU PWB did not receive a signal from the Cartridge Sensor when the Rotary Frame moved the Cyan Developer Housing into position.

Step	Actions and Questions	Yes	No
	<p><b>SUSPECT COMPONENTS</b> The following components are associated with this specific problem. One or more of these components may have failed partially or completely. If you cannot isolate the problem using this FIP, replace each component listed below, one at a time, until the problem disappears.</p> <ul style="list-style-type: none"> <li>• Wiring and connectors linking the components</li> <li>• Rotary Frame Assembly (RRP 9.67)</li> </ul>		
<b>1</b>	<p><b>CYAN TONER CARTRIDGE RESEAT</b> 1. Remove the Cyan Toner Cartridge. 2. Reinstall the Cyan Toner Cartridge. <b>Does the error message still appear?</b></p>	Go to step 2	Treat as an intermittent problem.
<b>2</b>	<p>Replace the Cyan Toner Cartridge (RRP 9.57) <b>Does the error message still appear?</b></p>	Go to step 3	Problem solved
<b>3</b>	<p>Replace the Toner Cartridge Sensor (RRP 9.69) <b>Does the error message still appear?</b></p>	Go to step 4	Problem solved
<b>4</b>	<p>Replace the MCU PWB (RRP 9.123) <b>Does the error message still appear?</b></p>	Go to suspect components	Problem solved

### 3.29 - Error Message: Magenta Toner Missing

**The Magenta Toner Cartridge is either not installed or not installed correctly.**

Logic control on the MCU PWB did not receive a signal from the Cartridge Sensor when the Rotary Frame moved the Magenta Developer Housing into position.

Step	Actions and Questions	Yes	No
	<p><b>SUSPECT COMPONENTS</b>                      The following components are associated with this specific problem. One or more of these components may have failed partially or completely. If you cannot isolate the problem using this FIP, replace each component listed below, one at a time, until the problem disappears.</p> <ul style="list-style-type: none"> <li>• Wiring and connectors linking the components</li> <li>• Rotary Frame Assembly (RRP 9.67)</li> </ul>		
<b>1</b>	<p><b>MAGENTA TONER CARTRIDGE RESEAT</b>                      1. Remove the Magenta Toner Cartridge.                      2. Reinstall the Magenta Toner Cartridge.  <b>Does the error message still appear?</b></p>	Go to step 2	Treat as an intermittent problem.
<b>2</b>	<p>Replace the Magenta Toner Cartridge (RRP 9.56)  <b>Does the error message still appear?</b></p>	Go to step 3	Problem solved
<b>3</b>	<p>Replace the Toner Cartridge Sensor (RRP 9.69)  <b>Does the error message still appear?</b></p>	Go to step 4	Problem solved
<b>4</b>	<p>Replace the MCU PWB (RRP 9.123)  <b>Does the error message still appear?</b></p>	Go to suspect components	Problem solved

### 3.30 - Error Message: Yellow Toner Missing

**The Yellow Toner Cartridge is either not installed or not installed correctly.**

Logic control on the MCU PWB did not receive a signal from the Cartridge Sensor when the Rotary Frame moved the Yellow Developer Housing into position.

Step	Actions and Questions	Yes	No
	<p><b>SUSPECT COMPONENTS</b> The following components are associated with this specific problem. One or more of these components may have failed partially or completely. If you cannot isolate the problem using this FIP, replace each component listed below, one at a time, until the problem disappears.</p> <ul style="list-style-type: none"> <li>• Wiring and connectors linking the components</li> <li>• Rotary Frame Assembly (RRP 9.67)</li> </ul>		
<b>1</b>	<p><b>YELLOW TONER CARTRIDGE RESEAT</b> 1. Remove the Yellow Toner Cartridge. 2. Reinstall the Yellow Toner Cartridge. <b>Does the error message still appear?</b></p>	Go to step 2	Treat as an intermittent problem.
<b>2</b>	<p>Replace the Yellow Toner Cartridge (RRP 9.55) <b>Does the error message still appear?</b></p>	Go to step 3	Problem solved
<b>3</b>	<p>Replace the Toner Cartridge Sensor (RRP 9.69) <b>Does the error message still appear?</b></p>	Go to step 4	Problem solved
<b>4</b>	<p>Replace the MCU PWB (RRP 9.123) <b>Does the error message still appear?</b></p>	Go to suspect components	Problem solved

### 3.31 - Error Message: Call for Service Engine Memory

**There is a problem reading information from ROM or from RAM on the MCU PWB.**

Logic control on the MCU PWB could not read information in the ROM or in RAM.

Step	Actions and Questions	Yes	No
	<p><b>SUSPECT COMPONENTS</b>                      The following components are associated with this specific problem. One or more of these components may have failed partially or completely. If you cannot isolate the problem using this FIP, replace each component listed below, one at a time, until the problem disappears.</p> <ul style="list-style-type: none"> <li>• Wiring and connectors linking the components</li> <li>• Interlock switches and circuits</li> </ul>		
<b>1</b>	<p><b>PRINTER RESTART</b></p> <ol style="list-style-type: none"> <li>1. Switch off printer main power.</li> <li>2. Wait one minute</li> <li>3. Switch on printer main power.</li> </ol> <p><b>Does the error message still appear?</b></p>	Go to step 2	Treat as an intermittent problem
<b>2</b>	<p><b>+5VDC CHECK</b></p> <ol style="list-style-type: none"> <li>1. Remove the Rear Cover (RRP 9.4)</li> <li>2. Measure the voltage between P/J33-3 and Frame Ground.</li> </ol> <p><b>Do you measure +5VDC between P/J33-3 and Frame Ground?</b></p>	Go to step 3	Replace the LVPS (RRP 9.119)
<b>3</b>	<p>Replace the MCU PWB (RRP 9.123)</p> <p><b>Does the error message still appear?</b></p>	Replace the Controller PWB (RRP 9.129)	Problem solved



### 3.32 - Error Message: Waste Toner Box Missing

**The Waste Toner Box is not installed.**

Logic control on the MCU PWB detected that the Waste Toner Box Sensor was deactivated.

Step	Actions and Questions	Yes	No
	<p><b>SUSPECT COMPONENTS</b> The following components are associated with this specific problem. One or more of these components may have failed partially or completely. If you cannot isolate the problem using this FIP, replace each component listed below, one at a time, until the problem disappears.</p> <ul style="list-style-type: none"> <li>• Wiring and connectors linking the components</li> <li>• Waste Toner Box (RRP 9.49)</li> <li>• OPC Drum (RRP 9.48)</li> </ul>		
<b>1</b>	<p><b>WASTE TONER BOX RESEAT</b></p> <ol style="list-style-type: none"> <li>1. Open the Front Cover.</li> <li>2. Remove the Waste Toner Box.</li> <li>3. Reinstall the Waste Toner Box.</li> </ol> <p><b>Does the error message still appear?</b></p>	Go to step 2	Treat as an intermittent problem.
<b>2</b>	<p><b>PRINTER RESTART</b></p> <ol style="list-style-type: none"> <li>1. Switch off printer main power.</li> <li>2. Wait one minute.</li> <li>3. Switch on printer main power.</li> </ol> <p><b>Does the error message still appear?</b></p>	Go to step 3	Treat as an intermittent problem.
<b>3</b>	<p><b>WASTE TONER BOX SENSOR TEST</b></p> <ol style="list-style-type: none"> <li>1. Enter Diagnostics and test the Waste Toner Box Sensor input test.</li> <li>2. Open the Front Cover.</li> <li>3. Remove the Waste Toner Box.</li> <li>4. Read the test result in the Diagnostics Status Window.</li> <li>5. Manually actuate the Waste Toner Box sensor inside the Waste Toner Box cavity.</li> </ol> <p><b>In the diagnostics, is "actuated" displayed when you manually actuate the sensor?</b></p>	Replace the MCU PWB (RRP 9.123)	Go to step 4
<b>4</b>	<p>Replace the Waste Toner Sensor (RRP 9.53)</p> <p><b>Does the error message still appear?</b></p>	Go to suspect components	Problem solved

### 3.33 - Error Message: Call for Service Fuser Temp Low

**There is a problem with the temperature of the Fuser.**

Logic control on the MCU PWB detected that the Fuser temperature did not reach Set Standby temperature of 148°C within 6 minutes after you switched on main printer power.

Step	Actions and Questions	Yes	No
	<p><b>SUSPECT COMPONENTS</b>                      The following components are associated with this specific problem. One or more of these components may have failed partially or completely. If you cannot isolate the problem using this FIP, replace each component listed below, one at a time, until the problem disappears.</p> <ul style="list-style-type: none"> <li>• Main Fuser Assembly (RRP 9.81)</li> <li>• Wiring and connectors linking the components</li> <li>• Interlock switches and circuits</li> </ul>		
<b>1</b>	<p><b>FUSER INSPECTION</b></p> <ol style="list-style-type: none"> <li>1. Slide the Fuser Assembly out of the printer.</li> <li>2. Place your hand near, but not on, the Fuser Rolls.</li> </ol> <p><b>Do you feel any heat coming from the Fuser?</b></p>	Go to step 2	Go to step 3.
<b>2</b>	<p>Replace the Temperature Sensor Assembly (RRP 9.88)</p> <p><b>Does the error message still appear?</b></p>	Go to step 5	Problem solved
<b>3</b>	<p><b>FUSER FUSE AND THERMOSTAT CHECK</b></p> <ol style="list-style-type: none"> <li>1. Slide the Fuser Assembly out of the printer.</li> <li>2. Remove the two screws securing the Upper Fuser Assembly to the Main Fuser Assembly.</li> <li>3. Check for continuity across the Fuser Fuse.</li> <li>4. Check for continuity across the Fuser Thermostat.</li> </ol> <p><b>Is there continuity across both the Fuser Fuse and across the Fuser Thermostat?</b></p>	Go to step 4	Replace the Upper Fuser Assembly (RRP 9.87)
<b>4</b>	<p>Replace the Pressure Roll Heat Rod (RRP 9.85) and the Heat Roll Heat Rod (RRP 9.86).</p> <p><b>Does the error message still appear?</b></p>	Go to step 5	Problem solved
<b>5</b>	<p>Replace the MCU PWB (RRP 9.123)</p> <p><b>Does the error message still appear?</b></p>	Go to step 6	Problem Solved
<b>6</b>	<p>Replace the LVPS Assembly (RRP 9.119)</p> <p><b>Does the error message still appear?</b></p>	Go to suspect components	Problem solved

### 3.34 - Error Message: Call for Service Rotary Sensor

#### There is a problem with the Rotary Home Sensor.

Logic control on the MCU PWB detected that the Rotary Home Sensor did not actuate within 6 seconds after the start of the Rotary Motor.

Step	Actions and Questions	Yes	No
	<p><b>SUSPECT COMPONENTS</b> The following components are associated with this specific problem. One or more of these components may have failed partially or completely. If you cannot isolate the problem using this FIP, replace each component listed below, one at a time, until the problem disappears.</p> <ul style="list-style-type: none"> <li>• Wiring and connectors linking the components</li> <li>• Rotary Frame Assembly</li> <li>• Interlock switches and circuits</li> </ul>		
<b>1</b>	<p><b>PRINTER RESTART</b></p> <ol style="list-style-type: none"> <li>1. Switch off printer main power.</li> <li>2. Wait one minute</li> <li>3. Switch on printer main power.</li> </ol> <p><b>Does the error message still appear?</b></p>	Go to step 2	Treat as an intermittent problem.
<b>2</b>	<p><b>ROTARY MOTOR OBSERVATION</b></p> <ol style="list-style-type: none"> <li>1. Switch off printer main power.</li> <li>2. Remove the Rear Cover (RRP 9.4)</li> <li>3. Switch on printer main power.</li> <li>4. Observe the Rotary Motor as the printer goes through warm-up cycle.</li> </ol> <p><b>Does the Rotary Motor rotate as the printer goes through warm-up cycle?</b></p>	Go to step 3	Go to step 4
<b>3</b>	<p><b>ROTARY HOME SENSOR TEST</b></p> <ol style="list-style-type: none"> <li>1. Enter Diagnostics and test the Rotary Home Sensor input test.</li> <li>2. Read the test result in the Diagnostics Status Window.</li> <li>3. Cover the Rotary Home Sensor with a piece of tape.</li> </ol> <p><b>In the diagnostics, is "not actuated" displayed when you have blocked the sensor with tape?</b></p>	Replace the MCU PWB (RRP 9.123)	Replace the Rotary Sensor (RRP 9.68)
<b>4</b>	<p><b>ROTARY MOTOR TEST</b></p> <p>Enter Diagnostics and test the Rotary Motor.</p> <p><b>Does the Rotary Motor rotate when you run the Rotary Motor test?</b></p>	Replace the MCU PWB (RRP 9.123)	Replace the Rotary Motor Assembly (RRP 9.114)

### 3.35 - Error Message: Call for Service Environment Sensor

**There is a problem with the Environment Sensor circuit.**

Logic control on the MCU PWB detected an open Environment Sensor circuit.

Step	Actions and Questions	Yes	No
	<p><b>SUSPECT COMPONENTS</b>                      The following components are associated with this specific problem. One or more of these components may have failed partially or completely. If you cannot isolate the problem using this FIP, replace each component listed below, one at a time, until the problem disappears.</p> <ul style="list-style-type: none"> <li>• Wiring and connectors linking the components</li> </ul>		
<p><b>1</b></p>	<p>Replace the Temperature Sensor Assembly (RRP 9.88)</p> <p><b>Does the error message still appear?</b></p>	<p>Go to step 2</p>	<p>Problem solved</p>
<p><b>2</b></p>	<p>Replace the MCU PWB (RRP 9.123)</p> <p><b>Does the error message still appear?</b></p>	<p>Go to suspect components</p>	<p>Problem solved</p>

### 3.36 - Error Message: Call for Service Paper Motor

**There is a problem with the Paper Handling Motor.**

Logic control on the MCU PWB received a Failed signal from the Paper Handling Motor circuitry.

Step	Actions and Questions	Yes	No
	<p><b>SUSPECT COMPONENTS</b> The following components are associated with this specific problem. One or more of these components may have failed partially or completely. If you cannot isolate the problem using this FIP, replace each component listed below, one at a time, until the problem disappears.</p> <ul style="list-style-type: none"> <li>• Wiring and connectors linking the components</li> <li>• Interlock switches and circuits</li> </ul>		
<b>1</b>	<p><b>PAPER HANDLING MOTOR FAIL TEST</b> Enter Diagnostics and test the Paper Handling Motor Fail Signal input test. <b>Did the Run Paper Handling Motor test pass?</b></p>	Go to step 3	Go to step 2
<b>2</b>	<p><b>PRINTER RESTART</b></p> <ol style="list-style-type: none"> <li>1. Switch off printer main power.</li> <li>2. Wait one minute</li> <li>3. Switch on printer main power.</li> </ol> <p><b>Does the error message still appear?</b></p>	Go to step 3	Treat as an intermittent problem.
<b>3</b>	<p><b>PAPER HANDLING MOTOR TEST</b> Enter Diagnostics and test the Paper Handling Motor. <b>Does the Paper Handling Motor rotate when you run the test?</b></p>	Replace the MCU PWB (RRP 9.123)	Go to step 4
<b>4</b>	<p><b>+24VDC CHECK</b></p> <ol style="list-style-type: none"> <li>1. Remove the Rear Cover (RRP 9.4)</li> <li>2. Measure the voltage between P/J32-8 and Frame Ground.</li> </ol> <p><b>Do you measure +24VDC between P/J32-8 and Frame Ground?</b></p>	Replace the Paper Handling Motor Assembly (RRP 9.111)	Replace the LVPS (RRP 9.119)

### 3.37 - Error Message: Call for Service Low Density

The image density readings indicate a problem.

Logic control on the MCU PWB detected that the printer image density was unusually low and attempts failed to raise the density.

Step	Actions and Questions	Yes	No
	<p><b>SUSPECT COMPONENTS</b>                      The following components are associated with this specific problem. One or more of these components may have failed partially or completely. If you cannot isolate the problem using this FIP, replace each component listed below, one at a time, until the problem disappears.</p> <ul style="list-style-type: none"> <li>• Wiring and connectors linking the components</li> <li>• Developer Clutch Assembly (RRP 9.117)</li> </ul>		
<b>1</b>	<p><b>DISPENSE MOTOR INSPECTION</b>                      1. Remove the Rear Cover (RRP 9.4)                      2. Switch on printer main power.                      3. Observe the Dispense Motor.  <b>Does the Dispense Motor run?</b></p>	Go to step 3	Go to step 2
<b>2</b>	<p>Replace the Dispense Motor Assembly (RRP 9.116)  <b>Does the error message still appear?</b></p>	Go to step 3	Problem solved
<b>3</b>	<p><b>TONER CARTRIDGE INSPECTION</b>                      Remove each of the four Toner Cartridges and inspect them for damage and contents.  <b>Are the Toner Cartridges free of damage and are they relatively full of toner?</b></p>	Go to step 4	Replace the damaged or empty Toner Cartridge
<b>4</b>	<p>Replace the ADC Sensor Assembly (RRP 9.50)  <b>Does the error message still appear?</b></p>	Go to step 5	Problem solved
<b>5</b>	<p>Replace the MCU PWB (RRP 9.123)  <b>Does the error message still appear?</b></p>	Go to step 6	Problem solved
<b>6</b>	<p><b>DEVELOPER HOUSING INSPECTION</b>                      Hand rotate the Rotary Frame Assembly and inspect the magnet roll of each of the four Developer Housings for damage and toner presence.  <b>Are the Magnet Rolls free of obvious damage and are they evenly coated with toner?</b></p>	Go to step 7	Replace the Developer in the problem Housing or replace the Developer Housing Assy. (RRP 9.59)

**3.37 - Error Message: Call for Service Low Density, continued**

<b>Step</b>	<b>Actions and Questions</b>	<b>Yes</b>	<b>No</b>
<b>7</b>	Replace the OPC Drum (RRP 9.48) <b>Does the error message still appear?</b>	Go to step 8	Problem solved
<b>8</b>	Replace the HVPS (RRP 9.120) <b>Does the error message still appear?</b>	Go to suspect components	Problem solved

### 3.38 - Error Message: Call for Service High Density

The image density readings indicate a problem.

Logic control on the MCU PWB detected that the printer image density was unusually high and attempts failed to lower the density.

Step	Actions and Questions	Yes	No
	<p><b>SUSPECT COMPONENTS</b>                      The following components are associated with this specific problem. One or more of these components may have failed partially or completely. If you cannot isolate the problem using this FIP, replace each component listed below, one at a time, until the problem disappears.</p> <ul style="list-style-type: none"> <li>• Wiring and connectors linking the components</li> <li>• Developer Clutch Assembly (RRP 9.117)</li> </ul>		
<b>1</b>	<p><b>DISPENSE MOTOR INSPECTION</b></p> <ol style="list-style-type: none"> <li>1. Remove the Rear Cover (RRP 9.4)</li> <li>2. Switch on printer main power.</li> <li>3. Observe the Dispense Motor.</li> </ol> <p><b>Does the Dispense Motor continue running even though the image density is too high?</b></p>	Go to step 2	Go to step 3
<b>2</b>	<p>Replace the Dispense Motor Assembly (RRP 9.116)</p> <p><b>Does the error message still appear?</b></p>	Go to step 3	Problem solved
<b>3</b>	<p><b>TONER CARTRIDGE INSPECTION</b></p> <p>Remove each of the four Toner Cartridges and inspect them for damage and toner leakage.</p> <p><b>Are the Toner Cartridges free of damage and are they relatively clean?</b></p>	Go to step 4	Replace the dirty or damaged Toner Cartridge.
<b>4</b>	<p>Replace the ADC Sensor Assembly (RRP 9.50)</p> <p><b>Does the error message still appear?</b></p>	Go to step 5	Problem solved
<b>5</b>	<p>Replace the MCU PWB (RRP 9.123)</p> <p><b>Does the error message still appear?</b></p>	Go to step 6	Problem solved



**3.38 - Error Message: Call for Service High Density, continued**

Step	Actions and Questions	Yes	No
<b>6</b>	<b>DEVELOPER HOUSING INSPECTION</b> Hand rotate the Rotary Frame Assembly and inspect the magnet roll of each of the four Developer Housings for damage and toner leakage.  <b>Are the Magnet Rolls free of obvious damage and the area immediately around the Roll is relatively clean?</b>	Go to step 7	Replace the Developer in the Housing or replace the Developer Housing Assy. (RRP 9.59)
<b>7</b>	Replace the OPC Drum (RRP 9.48)  <b>Does the error message still appear?</b>	Go to step 8	Problem solved
<b>8</b>	Replace the HVPS (RRP 9.120)  <b>Does the error message still appear?</b>	Go to suspect components	Problem solved

### 3.39 - Error Message: Adjust Upper Bin

**There is a problem with the Upper Bin.**

Logic control on the MCU PWB did not detect the Upper Bin installed in Feeder 1.

Step	Actions and Questions	Yes	No
	<p><b>SUSPECT COMPONENTS</b>                      The following components are associated with this specific problem. One or more of these components may have failed partially or completely. If you cannot isolate the problem using this FIP, replace each component listed below, one at a time, until the problem disappears.</p> <ul style="list-style-type: none"> <li>• Wiring and connectors linking the components</li> </ul>		
<b>1</b>	<p><b>UPPER BIN INSPECTION</b>                      1. Remove the Upper Bin from Feeder 1.                      2. Inspect the Size Actuators at the rear of the Tray.  <b>Are the Actuators intact and free of damage?</b></p>	Go to step 2	Replace the Upper Bin.
<b>2</b>	<p>Replace the Size Switch Assembly (RRP 9.17)  <b>Does the error message still appear?</b></p>	Go to step 3	Problem solved
<b>3</b>	<p>Replace the MCU PWB (RRP 9.123)  <b>Does the error message still appear?</b></p>	Go to suspect components	Problem solved

### 3.40 - Error Message: Call for Service Fuser Lamp

**There is a problem with the Fuser Lamp control.**

Logic control on the MCU PWB detected that the Fuser Lamp remained on longer than the specified time.

Step	Actions and Questions	Yes	No
	<p><b>SUSPECT COMPONENTS</b>                      The following components are associated with this specific problem. One or more of these components may have failed partially or completely. If you cannot isolate the problem using this FIP, replace each component listed below, one at a time, until the problem disappears.</p> <ul style="list-style-type: none"> <li>• Main Fuser Assembly (RRP 9.81)</li> <li>• Wiring and connectors linking the components</li> </ul>		
<b>1</b>	Replace the Temperature Sensor Assembly (RRP 9.88)  <b>Does the error message still appear?</b>	Go to step 2	Problem solved
<b>2</b>	Replace the MCU PWB (RRP 9.123)  <b>Does the error message still appear?</b>	Go to step 3	Problem solved
<b>3</b>	Replace the LVPS Assembly (RRP 9.119)  <b>Does the error message still appear?</b>	Go to suspect components	Problem solved

### 3.41 - Error Message: Adjust Opt2 Bin

**There is a problem with Feeder 2.**

Logic control on the MCU PWB did not detect a OPT2 Bin installed in Feeder 2.

Step	Actions and Questions	Yes	No
	<p><b>SUSPECT COMPONENTS</b>                      The following components are associated with this specific problem. One or more of these components may have failed partially or completely. If you cannot isolate the problem using this FIP, replace each component listed below, one at a time, until the problem disappears.</p> <ul style="list-style-type: none"> <li>• Wiring and connectors linking the LCIF to the Base Engine</li> <li>• Wiring and connectors linking the components</li> </ul>		
<b>1</b>	<p><b>OPT2 BIN INSPECTION</b>                      1. Remove the Paper Tray from Feeder 2.                      2. Inspect the Size Actuators at the rear of the Tray.  <b>Are the Actuators intact and free of damage?</b></p>	Go to step 2	Replace the OPT2 Bin.
<b>2</b>	<p>Replace the Feeder 2 Size Switch Assembly (LCIF RRP 6.13)  <b>Does the error message still appear?</b></p>	Go to step 3	Problem solved
<b>3</b>	<p>Replace the Feeder PWB (LCIF RRP 6.10)  <b>Does the error message still appear?</b></p>	Go to step 4	Problem solved
<b>4</b>	<p>Replace the MCU PWB (RRP 9.123)  <b>Does the error message still appear?</b></p>	Go to suspect components	Problem solved

### 3.42 - Error Message: Adjust Opt1 Bin

#### There is a problem with Feeder 1.

Logic control on the MCU PWB did not detect the OPT1 Bin installed in Feeder 1.

Step	Actions and Questions	Yes	No
	<p><b>SUSPECT COMPONENTS</b> The following components are associated with this specific problem. One or more of these components may have failed partially or completely. If you cannot isolate the problem using this FIP, replace each component listed below, one at a time, until the problem disappears.</p> <ul style="list-style-type: none"> <li>• Wiring and connectors linking the LCIF to the Base Engine</li> <li>• Wiring and connectors linking the components</li> </ul>		
<b>1</b>	<p><b>OPT1 BIN INSPECTION</b> 1. Remove the Paper Tray from Feeder 1. 2. Inspect the Size Actuators at the rear of the Tray. <b>Are the Actuators intact and free of damage?</b></p>	Go to step 2	Replace the OPT1 Bin.
<b>2</b>	<p>Replace the Feeder 1 Size Switch Assembly (RRP 9.13) <b>Does the error message still appear?</b></p>	Go to step 3	Problem solved
<b>3</b>	<p>Replace the Feeder PWB (LCIF RRP 6.10) <b>Does the error message still appear?</b></p>	Go to step 4	Problem solved
<b>4</b>	<p>Replace the MCU PWB (LCIF RRP 6.123) <b>Does the error message still appear?</b></p>	Go to suspect components	Problem solved

### 3.43 - Error Message: Call for Service Main Motor

**There is a problem with the Main Motor.**

Logic control on the MCU PWB did not receive a status signal from the TR0 Sensor signal in the specified time.

Step	Actions and Questions	Yes	No
	<p><b>SUSPECT COMPONENTS</b>                      The following components are associated with this specific problem. One or more of these components may have failed partially or completely. If you cannot isolate the problem using this FIP, replace each component listed below, one at a time, until the problem disappears.</p> <ul style="list-style-type: none"> <li>• Wiring and connectors linking the components</li> <li>• Interlock switches and circuits</li> </ul>		
<b>1</b>	<p><b>MAIN MOTOR TEST</b>                      Enter Diagnostics and test the Main Motor.</p> <p><b>Does the Main Motor rotate when you run the test?</b></p>	Go to step 5	Go to step 2
<b>2</b>	<p><b>MAIN MOTOR TEST 2</b>                      1. Remove the OPC Drum from the printer.                      2. Enter Diagnostics and test the Main Motor.</p> <p><b>Does the Main Motor rotate when you run the test?</b></p>	Replace the OPC Drum (RRP 9.48)	Go to step 3
<b>3</b>	<p><b>+24VDC CHECK</b>                      1. Remove the Rear Cover (RRP 9.4)                      2. Measure the voltage between P/J32-9 and Frame Ground.</p> <p><b>Do you measure +24VDC between P/J32-9 and Frame Ground?</b></p>	Go to step 4	Replace the LVPS (RRP 9.119)
<b>4</b>	<p>Replace the MCU PWB (RRP 9.123)</p> <p><b>Does the error message still appear?</b></p>	Replace the Process Drive Assembly (RRP 9.113)	Problem solved
<b>5</b>	<p><b>IBT INSPECTION</b>                      Remove the OPC Drum and inspect the IBT for obvious damage along the rear edge.</p> <p><b>Is the IBT free of any obvious damage?</b></p>	Go to step 6	Replace the IBT Belt Assembly (RRP 9.78)
<b>6</b>	<p>Replace the TR0 Sensor (RRP 9.79)</p> <p><b>Does the error message still appear?</b></p>	Replace the MCU PWB (RRP 9.123)	Problem solved

### 3.44 - Error Message: Call for Service ROS Motor

**There is a problem with the ROS Motor.**

Logic control on the MCU PWB did not receive a signal from the SOS Sensor within the specified time.

Step	Actions and Questions	Yes	No
	<p><b>SUSPECT COMPONENTS</b> The following components are associated with this specific problem. One or more of these components may have failed partially or completely. If you cannot isolate the problem using this FIP, replace each component listed below, one at a time, until the problem disappears.</p> <ul style="list-style-type: none"> <li>• Interlock switches in the 5VDC-LD circuit</li> <li>• Wiring and connectors linking the components</li> <li>• LVPS (RRP 9.119)</li> </ul>		
<b>1</b>	<p><b>SOS SIGNAL TEST</b> <b>NOTE: Remove the OPC from the MC330 because it may be damaged with this test.</b> Enter Diagnostics and test the SOS Error Signal input test (Sensor). <b>Did the Start of Scan Sensor test pass?</b></p>	Go to step 3	Go to step 2
<b>2</b>	<p><b>PRINTER RESTART</b></p> <ol style="list-style-type: none"> <li>1. Switch off printer main power.</li> <li>2. Wait one minute</li> <li>3. Switch on printer main power.</li> </ol> <p><b>Does the error message still appear?</b></p>	Go to step 3	Treat as an intermittent problem.
<b>3</b>	<p><b>ROS MOTOR TEST</b> Enter Diagnostics and test the ROS Motor. <b>Can you hear the ROS Motor rotate when you run the test, and does diagnostics report pass?</b></p>	Replace the MCU PWB (RRP 9.123)	Replace the ROS Assembly (RRP 9.47)

### 3.45 - Error Message: Call for Service Fuser Temp High

**There is a problem with the Fuser.**

Based on the Thermistor signal indicating that the Fuser had reached the set overheat temperature, logic control on the MCU PWB shutdown Fuser operation.

Step	Actions and Questions	Yes	No
	<p><b>SUSPECT COMPONENTS</b>                      The following components are associated with this specific problem. One or more of these components may have failed partially or completely. If you cannot isolate the problem using this FIP, replace each component listed below, one at a time, until the problem disappears.</p> <ul style="list-style-type: none"> <li>• Main Fuser Assembly (RRP 9.81)</li> <li>• Wiring and connectors linking the components</li> </ul>		
<b>1</b>	<p><b>PRINTER RESTART</b></p> <ol style="list-style-type: none"> <li>1. Switch off printer main power.</li> <li>2. Wait 45 minutes for the Fuser to cool.</li> <li>3. Switch on printer main power.</li> </ol> <p><b>Does the error message still appear?</b></p>	Go to step 2	Treat as intermittent. If problem reoccurs, resume troubleshooting at step 2.
<b>2</b>	<p><b>FUSER FAN INSPECTION</b>                      Observe the Fuser Fan.</p> <p><b>Does the Fan rotate smoothly?</b></p>	Go to step 4	Go to step 3
<b>3</b>	<p>Replace the Fuser Fan (RRP 9.108)</p> <p><b>Does the error message still appear?</b></p>	Go to step 4	Problem solved
<b>4</b>	<p>Replace the Temperature Sensor Assembly (RRP 9.88)</p> <p><b>Does the error message still appear?</b></p>	Go to step 5	Problem solved
<b>5</b>	<p>Replace the LVPS Assembly (RRP 9.119)</p> <p><b>Does the error message still appear?</b></p>	Go to step 6	Problem solved
<b>6</b>	<p>Replace the MCU PWB (RRP 9.123)</p> <p><b>Does the error message still appear?</b></p>	Go to suspect components	Problem Solved



### 3.46 - Error Message: Excessive Toner Coverage

#### Image density exceeded design specifications.

Logic control on the MCU PWB detected that the first 70mm of the lead edge of the four color image about to be printed exceeds the design specification for total image density. The specification is 280% or less image density. For example, a density setting of 100% for each of the four colors creates a layered four color image with a combined density of 400%.

Step	Actions and Questions	Yes	No
	<p><b>SUSPECT COMPONENTS</b> The following components are associated with this specific problem. One or more of these components may have failed partially or completely. If you cannot isolate the problem using this FIP, replace each component listed below, one at a time, until the problem disappears.</p> <ul style="list-style-type: none"> <li>• Wiring and connectors linking the components</li> </ul>		
<b>1</b>	<p><b>PRINTER RESTART</b></p> <ol style="list-style-type: none"> <li>1. Switch off printer main power.</li> <li>2. Wait one minute.</li> <li>3. Switch on printer main power.</li> <li>4. Send the same print request to the printer.</li> </ol> <p><b>Does the error message still appear?</b></p>	Go to step 2	Treat as intermittent. If problem reoccurs, resume troubleshooting at step 2.
<b>2</b>	<p><b>PRINT REQUEST CANCELLATION</b></p> <ol style="list-style-type: none"> <li>1. Cancel the print request that is causing the error message.</li> <li>2. Print another, much less complex, color image.</li> </ol> <p><b>Does the second image generate the same error message?</b></p>	Replace the MCU PWB (RRP 9.123)	Do not send overly dense images to the printer.

### 3.47 - Error Message: Fuser Missing

**There is a problem with the Fuser Unit.**

Logic control on the MCU PWB senses an open Fuser Temperature Sensor circuit.

Step	Actions and Questions	Yes	No
	<p><b>SUSPECT COMPONENTS</b>                      The following components are associated with this specific problem. One or more of these components may have failed partially or completely. If you cannot isolate the problem using this FIP, replace each component listed below, one at a time, until the problem disappears.</p> <ul style="list-style-type: none"> <li>• Wiring and connectors linking the components</li> </ul>		
<b>1</b>	<p><b>FUSER ASSEMBLY RESEAT</b></p> <ol style="list-style-type: none"> <li>1. Slide the Fuser Assembly out of the printer.</li> <li>2. Slide the Fuser Assembly into the printer.</li> </ol> <p><b>Does the error message still appear?</b></p>	Go to step 2	Problem solved
<b>2</b>	<p><b>FUSER ASSEMBLY P/J70 &amp; P/J71 INSPECTION</b></p> <ol style="list-style-type: none"> <li>1. Slide the Fuser Assembly out of the printer.</li> <li>2. Inspect the P/J that is located at the rear of the Fuser Assembly.</li> <li>3. Inspect the mating P/J that is located at the rear of the printer, just below the Fuser Fan.</li> </ol> <p><b>Are both P/Js undamaged and do the two mate correctly when you slide the Fuser Assembly into the printer?</b></p>	Go to step 3	Replace the Fuser Assembly (9.80) or replace the Fuser Harness Assembly (PL9.3.26) and the Fuser Connector (PL13.1.13)
<b>3</b>	<p>Replace the Temperature Sensor Assembly (RRP 9.88)</p> <p><b>Does the error message still appear?</b></p>	Go to step 4	Problem Solved
<b>4</b>	<p>Replace the MCU PWB (RRP 9.123)</p> <p><b>Does the error message still appear?</b></p>	Go to suspect components	Problem Solved

### 3.48 - Error Message: Fuser Oil Roll Missing

**There is problem with the Fuser Oil Roll Assembly.**

Logic control on the MCU PWB detected that the Fuser Oil Roll Assembly circuit is open.

Step	Actions and Questions	Yes	No
	<p><b>SUSPECT COMPONENTS</b> The following components are associated with this specific problem. One or more of these components may have failed partially or completely. If you cannot isolate the problem using this FIP, replace each component listed below, one at a time, until the problem disappears.</p> <ul style="list-style-type: none"> <li>• Wiring and connectors linking the components</li> </ul>		
<b>1</b>	<p><b>FUSER OIL ROLL ASSEMBLY RESEAT</b></p> <ol style="list-style-type: none"> <li>1. Slide the Fuser Assembly out of the printer.</li> <li>2. Remove the Oil Roll Assembly from the Fuser Assembly.</li> <li>3. Reinstall the Oil Roll Assembly into the Fuser Assembly.</li> </ol> <p><b>Does the error message still appear?</b></p>	Go to step 2	Problem solved
<b>2</b>	<p><b>FUSER ASSEMBLY P/J77 INSPECTION</b></p> <ol style="list-style-type: none"> <li>1. Slide the Fuser Assembly out of the printer.</li> <li>2. Remove the Oil Roll Assembly from the Fuser Assembly.</li> <li>3. Inspect the two metal contacts that are located at the rear of the Oil Roll Assembly.</li> <li>4. Inspect the mating springs that are located at the rear of the Fuser Assembly.</li> </ol> <p><b>Are both the springs and the contacts undamaged and do they mate correctly when you reinstall the Oil Roll Assembly into the Fuser Assembly?</b></p>	Go to step 3	Replace the Oil Roll Assembly (RRP 9.82) and if necessary, replace the Fuser Assembly (RRP 9.80)
<b>3</b>	<p><b>FUSER ASSEMBLY P/J70 &amp; P/J71 INSPECTION</b></p> <ol style="list-style-type: none"> <li>1. Slide the Fuser Assembly out of the printer.</li> <li>2. Inspect the P/J that is located at the rear of the Fuser Assembly.</li> <li>3. Inspect the mating P/J that is located at the rear of the printer, just below the Fuser Fan.</li> </ol> <p><b>Are both P/Js undamaged and do the two mate correctly when you slide the Fuser Assembly into the printer?</b></p>	Go to step 4	Replace the Fuser Assembly (RRP 9.80) or replace the Fuser Harness Assembly (PL9.3.26) and the Fuser Connector (PL13.1.13)
<b>4</b>	<p>Replace the MCU PWB (RRP 9.123)</p> <p><b>Does the error message still appear?</b></p>	Go to suspect components	Problem Solved

### 3.49 - Error Message: Call for Service Fuser Warm-up

**There is problem with the Fuser Unit.**

Logic control on the MCU PWB detected that the Fuser did not reach ready temperature during the specified time.

Step	Actions and Questions	Yes	No
	<p><b>SUSPECT COMPONENTS</b>                      The following components are associated with this specific problem. One or more of these components may have failed partially or completely. If you cannot isolate the problem using this FIP, replace each component listed below, one at a time, until the problem disappears.</p> <ul style="list-style-type: none"> <li>• Main Fuser Assembly (RRP 9.81)</li> <li>• Wiring and connectors linking the components</li> <li>• Interlock switches and circuits</li> </ul>		
<b>1</b>	<p><b>FUSER INSPECTION</b></p> <ol style="list-style-type: none"> <li>1. Switch on printer main power.</li> <li>2. Wait 5 minutes.</li> <li>3. Slide the Fuser Assembly out of the printer.</li> <li>4. Place your hand near, but not on, the Fuser Rolls.</li> </ol> <p><b>Do you feel any heat coming from the Fuser?</b></p>	Go to step 2	Go to step 3.
<b>2</b>	<p>Replace the Temperature Sensor Assembly (RRP 9.88)</p> <p><b>Does the error message still appear?</b></p>	Go to step 5	Problem solved
<b>3</b>	<p><b>FUSER FUSE AND THERMOSTAT CHECK</b></p> <ol style="list-style-type: none"> <li>1. Slide the Fuser Assembly out of the printer.</li> <li>2. Remove the two screws securing the Upper Fuser Assembly to the Main Fuser Assembly.</li> <li>3. Check for continuity across the Fuser Fuse.</li> <li>4. Check for continuity across the Fuser Thermostat.</li> </ol> <p><b>Is there continuity across both the Fuser Fuse and across the Fuser Thermostat?</b></p>	Go to step 4	Replace the Upper Fuser Assembly (RRP 9.87)
<b>4</b>	<p>Replace the Pressure Roll Heat Rod (RRP 9.85) and the Heat Roll Heat Rod (RRP 9.86).</p> <p><b>Does the error message still appear?</b></p>	Got to step 5	Problem solved
<b>5</b>	<p>Replace the MCU PWB (RRP 9.123)</p> <p><b>Does the error message still appear?</b></p>	Go to step 6	Problem Solved
<b>6</b>	<p>Replace the LVPS Assembly (RRP 9.119)</p> <p><b>Does the error message still appear?</b></p>	Go to suspect components	Problem solved

### 3.50 - Error Message: Call for Service BTR2 Error

**There is a problem with BTR2.**

Logic control on the MCU PWB detected that the current value measured across BTR2 was not within specifications.

Step	Actions and Questions	Yes	No
	<p><b>SUSPECT COMPONENTS</b>            The following components are associated with this specific problem. One or more of these components may have failed partially or completely. If you cannot isolate the problem using this FIP, replace each component listed below, one at a time, until the problem disappears.</p> <ul style="list-style-type: none"> <li>• Wiring and connectors linking the components</li> <li>• Belt Cleaner Assembly (RRP 9.76)</li> </ul>		
<b>1</b>	Replace the HVPS (RRP 9.120)  <b>Does the error message still appear?</b>	Go to step 2	Problem solved
<b>2</b>	Replace the MCU PWB (RRP 9.123)  <b>Does the error message still appear?</b>	Go to step 3	Problem solved
<b>3</b>	Replace the 2nd BTR Assembly (RRP 9.75)  <b>Does the error message still appear?</b>	Go to step 4	Problem solved
<b>4</b>	Replace the IBT Belt Assembly (RRP 9.78)  <b>Does the error message still appear?</b>	Go to suspect components	Problem solved

### 3.52 - Error Message: Replace Fuser

**The Fuser has reached end of life.**

Logic control on the MCU PWB detected that the Fuser has been installed while print engine has processed 250,000 images or the print engine has accumulated more than 19.5 hours of toner dispensing time.

Step	Actions and Questions	Yes	No
	<p><b>SUSPECT COMPONENTS</b>                      The following components are associated with this specific problem. One or more of these components may have failed partially or completely. If you cannot isolate the problem using this FIP, replace each component listed below, one at a time, until the problem disappears.</p> <ul style="list-style-type: none"> <li>• Wiring and connectors linking the components</li> </ul>		
<b>1</b>	Replace the Fuser Assembly (RRP 9.80)  <b>Does the error message still appear?</b>	Go to step 2	Problem solved
<b>2</b>	Replace the MCU PWB (RRP 9.123)  <b>Does the error message still appear?</b>	Go to suspect components	Problem solved

### 3.53 - Error Message: Replace IBT Belt Cleaner

#### The IBT Belt Cleaner has reached end of life.

Logic control on the MCU PWB detected that the IBT Cleaner has processed over 180,000 sheets of paper.

Step	Actions and Questions	Yes	No
	<p><b>SUSPECT COMPONENTS</b> The following components are associated with this specific problem. One or more of these components may have failed partially or completely. If you cannot isolate the problem using this FIP, replace each component listed below, one at a time, until the problem disappears.</p> <ul style="list-style-type: none"> <li>• Wiring and connectors linking the components</li> </ul>		
<b>1</b>	Replace the Belt Cleaner Assembly (RRP 9.76)  <b>Does the error message still appear?</b>	Go to step 2	Problem solved
<b>2</b>	Replace the MCU PWB (RRP 9.123)  <b>Does the error message still appear?</b>	Go to suspect components	Problem solved

### 3.54 - Error Message: Replace BTR2

**BTR2 has reached end of life.**

Logic control on the MCU PWB detected that BTR2 has processed over 100,000 images.

Step	Actions and Questions	Yes	No
	<p><b>SUSPECT COMPONENTS</b>                      The following components are associated with this specific problem. One or more of these components may have failed partially or completely. If you cannot isolate the problem using this FIP, replace each component listed below, one at a time, until the problem disappears.</p> <ul style="list-style-type: none"> <li>• Wiring and connectors linking the components</li> </ul>		
<p><b>1</b></p>	<p>Replace the 2nd BTR Assembly (RRP 9.75)</p> <p><b>Does the error message still appear?</b></p>	<p>Go to step 2</p>	<p>Problem solved</p>
<p><b>2</b></p>	<p>Replace the MCU PWB (RRP 9.123)</p> <p><b>Does the error message still appear?</b></p>	<p>Go to suspect components</p>	<p>Problem solved</p>



### 3.55 - Error Message: Replace OPC Drum

**The OPC Drum has reached end of life.**

Logic control on the MCU PWB detected that the OPC Drum has printed 110,000 images.

Step	Actions and Questions	Yes	No
	<p><b>SUSPECT COMPONENTS</b>            The following components are associated with this specific problem. One or more of these components may have failed partially or completely. If you cannot isolate the problem using this FIP, replace each component listed below, one at a time, until the problem disappears.</p> <ul style="list-style-type: none"> <li>• Wiring and connectors linking the components</li> </ul>		
<b>1</b>	Replace the OPC Drum (RRP 9.48)  <b>Does the error message still appear?</b>	Go to step 2	Problem solved
<b>2</b>	Replace the MCU PWB (RRP 9.123)  <b>Does the error message still appear?</b>	Go to suspect components	Problem solved

### 3.56 - Error Message: Feeder Cover Missing

**There is a problem with the Large Capacity Input Feeder Cover.**

Logic control on the MCU PWB detected that the LCIF Feeder Cover Interlock is deactivated.

Step	Actions and Questions	Yes	No
	<p><b>SUSPECT COMPONENTS</b>                      The following components are associated with this specific problem. One or more of these components may have failed partially or completely. If you cannot isolate the problem using this FIP, replace each component listed below, one at a time, until the problem disappears.</p> <ul style="list-style-type: none"> <li>• Wiring and connectors linking the components</li> </ul>		
<b>1</b>	<p><b>FEEDER COVER MISSING</b>                      1. Open the Feeder Cover.                      2. Firmly close the Feeder Cover.  <b>Does the error message still appear?</b></p>	Go to step 2	Problem solved
<b>2</b>	<p><b>LCIF FEEDER COVER SWITCH INSPECTION</b>                      1. Open the Feeder Cover.                      2. Inspect the Feeder Cover Switch actuator that is located near the top-rear of the Cover.  <b>Is the actuator free of damage?</b></p>	Go to step 4	Go to step 3
<b>3</b>	<p>Replace the LCIF Cover Assembly (LCIF RRP 6.8)  <b>Does the error message still appear?</b></p>	Go to step 4	Problem Solved
<b>4</b>	<p>Replace the Feeder Cover Switches (LCIF RRP 6.14)  <b>Does the error message still appear?</b></p>	Go to step 5	Problem Solved
<b>5</b>	<p>Replace the Feeder PWB (LCIF RRP 6.10)  <b>Does the error message still appear?</b></p>	Go to step 6	Problem Solved
<b>6</b>	<p>Replace the MCU PWB (RRP 9.123)  <b>Does the error message still appear?</b></p>	Go to suspect components	Problem Solved

### 3.57 - Error Message: Fuser Unit Missing

#### There is a problem with the Fuser Unit.

Logic control on the MCU PWB detected that the Fuser Interlock circuit is open.

Step	Actions and Questions	Yes	No
	<p><b>SUSPECT COMPONENTS</b> The following components are associated with this specific problem. One or more of these components may have failed partially or completely. If you cannot isolate the problem using this FIP, replace each component listed below, one at a time, until the problem disappears.</p> <ul style="list-style-type: none"> <li>• Wiring and connectors linking the components</li> <li>• Obstructions or damage in the Fuser Unit docking area inside the printer</li> </ul>		
<b>1</b>	<p><b>FUSER UNIT RESEAT</b></p> <ol style="list-style-type: none"> <li>1. Slide the Fuser Unit out of the printer.</li> <li>2. Slide the Fuser Unit into the printer.</li> </ol> <p><b>Does the error message still appear?</b></p>	Go to step 2	Problem solved
<b>2</b>	<p><b>FUSER UNIT P/J70 &amp; P/J71 INSPECTION</b></p> <ol style="list-style-type: none"> <li>1. Slide the Fuser Unit out of the printer.</li> <li>2. Inspect the P/J that is located at the rear of the Fuser Unit.</li> <li>3. Inspect the mating P/J that is located at the rear of the printer, just below the Fuser Fan.</li> </ol> <p><b>Are both P/Js undamaged and do the two mate correctly when you slide the Fuser Assembly into the printer?</b></p>	Go to step 3	Replace the Fuser Unit (9.80) or replace the Fuser Harness Assembly (PL9.3.26) and the Fuser Connector (PL13.1.13)
<b>3</b>	<p>Replace the MCU PWB (RRP 9.123)</p> <p><b>Does the error message still appear?</b></p>	Go to suspect components	Problem Solved

### 3.58 - Error Message: Exit Cover Open

**There is a problem with the Exit Cover.**

Logic control on the MCU PWB detected that the Exit Cover Interlock Switch is deactivated.

Step	Actions and Questions	Yes	No
	<p><b>SUSPECT COMPONENTS</b>                      The following components are associated with this specific problem. One or more of these components may have failed partially or completely. If you cannot isolate the problem using this FIP, replace each component listed below, one at a time, until the problem disappears.</p> <ul style="list-style-type: none"> <li>• Wiring and connectors linking the components</li> </ul>		
<b>1</b>	<p><b>EXIT COVER RESEAT</b></p> <ol style="list-style-type: none"> <li>1. Open the Exit Cover.</li> <li>2. Firmly close the Exit Cover.</li> </ol> <p><b>Does the error message still appear?</b></p>	Go to step 2	Problem solved
<b>2</b>	<p><b>EXIT COVER ACTUATOR INSPECTION</b></p> <ol style="list-style-type: none"> <li>1. Open the Exit Cover.</li> <li>2. Inspect the Exit Cover Interlock Switch actuator that is located at the top-rear of the Cover.</li> </ol> <p><b>Is the actuator free of damage?</b></p>	Go to step 3	Replace the Upper Exit Assembly (RRP 9.102)
<b>3</b>	<p>Replace the Exit Cover Switch (RRP 9.107)</p> <p><b>Does the error message still appear?</b></p>	Replace the MCU PWB (RRP 9.123)	Problem Solved

### 3.59 - Error Message: MPT Tray Open

#### There is a problem with the Main Paper Tray.

Logic control on the MCU PWB detected that the Main Paper Tray Interlock circuit is open.

Step	Actions and Questions	Yes	No
	<p><b>SUSPECT COMPONENTS</b> The following components are associated with this specific problem. One or more of these components may have failed partially or completely. If you cannot isolate the problem using this FIP, replace each component listed below, one at a time, until the problem disappears.</p> <ul style="list-style-type: none"> <li>• Wiring and connectors linking the components</li> <li>• Obstructions or damage in the Main Paper Tray docking area inside the printer</li> </ul>		
<b>1</b>	<p><b>MAIN PAPER TRAY RESEAT</b></p> <ol style="list-style-type: none"> <li>1. Slide the Main Paper Tray out of the printer.</li> <li>2. Slide the Main Paper Tray back into the printer.</li> </ol> <p><b>Does the error message still appear?</b></p>	Go to step 2	Problem solved
<b>2</b>	<p><b>MAIN PAPER TRAY P/J91 &amp; P/J97 INSPECTION</b></p> <ol style="list-style-type: none"> <li>1. Slide the Main Paper Tray out of the printer.</li> <li>2. Inspect the P/J that is located under the Assembly.</li> <li>3. Inspect the mating P/J that is located inside the printer, just below the MCU PWB card cage.</li> </ol> <p><b>Are both P/Js undamaged and do the two mate correctly when you slide the Assembly into the printer?</b></p>	Go to step 3	Replace the Main Paper Tray (RRP 9.36) or replace the Registration Harness Assy. (PL5.2.33) and the Paper Handling Harness Assy. (PL13.2.20)
<b>3</b>	<p>Replace the MCU PWB (RRP 9.123)</p> <p><b>Does the error message still appear?</b></p>	Go to suspect components	Problem Solved

### 3.60 - Error Message: Front Cover Open

**There is a problem with the Front Cover.**

Logic control on the MCU PWB detected that one or both of the Front Cover Interlock Switches is deactivated.

Step	Actions and Questions	Yes	No
	<p><b>SUSPECT COMPONENTS</b>                      The following components are associated with this specific problem. One or more of these components may have failed partially or completely. If you cannot isolate the problem using this FIP, replace each component listed below, one at a time, until the problem disappears.</p> <ul style="list-style-type: none"> <li>• Wiring and connectors linking the components</li> </ul>		
<b>1</b>	<p><b>FRONT COVER RESEAT</b>                      1. Open the Front Cover.                      2. Firmly close the Front Cover.  <b>Does the error message still appear?</b></p>	Go to step 2	Problem solved
<b>2</b>	<p><b>FRONT COVER ACTUATOR INSPECTION</b>                      1. Open the Front Cover.                      2. Inspect the Front Cover Interlock Switch actuators that are located near the center-right and near the top-left on the back of the Cover.  <b>Is the actuator free of damage?</b></p>	Go to step 3	Replace the Front Cover Assembly (RRP 9.1)
<b>3</b>	<p>Replace the Front Cover Switch R (RRP 9.124)  <b>Does the error message still appear?</b></p>	Go to step 4	Problem Solved
<b>4</b>	<p>Replace the Front Cover Switch L (RRP 9.125)  <b>Does the error message still appear?</b></p>	Replace the MCU PWB (RRP 9.123)	Problem Solved

### 3.61 - Error Message: Top Stack Full

#### The Top Stack is full.

Logic control on the MCU PWB detected that the Full Stack Sensor is actuated for more than 12 seconds.

Step	Actions and Questions	Yes	No
	<p><b>SUSPECT COMPONENTS</b> The following components are associated with this specific problem. One or more of these components may have failed partially or completely. If you cannot isolate the problem using this FIP, replace each component listed below, one at a time, until the problem disappears.</p> <ul style="list-style-type: none"> <li>• Wiring and connectors linking the components</li> <li>• Top Cover Assembly (RRP 9.3)</li> </ul>		
<b>1</b>	<p><b>OUTPUT TRAY INSPECTION</b> Count the sheets of paper in the Output Tray.</p> <p><b>Are there over 250 sheets of paper, no heavier than 28 lb. stock, in the Output Tray?</b></p>	The Output Tray has reached the set limit. Remove the paper from the Output Tray.	Go to step 2
<b>2</b>	<p><b>FULL STACK SENSOR INSPECTION</b> Inspect the Sensor and Sensor Actuator area for paper scraps that might cause the Sensor to stick.</p> <p><b>Is the area free of paper scraps?</b></p>	Go to step 3	Remove all paper scraps from the area
<b>3</b>	<p><b>FULL STACK SENSOR TEST</b></p> <ol style="list-style-type: none"> <li>1. Enter Diagnostics and test the Full Stack Sensor --Top input test.</li> <li>2. Observe the last number in the Diagnostic Status Window.</li> <li>3. Load 250 sheets of paper into the Output Tray.</li> </ol> <p><b>Does the diagnostics return a "Actuated" response?</b></p>	Go to step 4	Replace the Full Stack Sensor (RRP 9.103)
<b>4</b>	<p>Replace the MCU PWB (RRP 9.123)</p> <p><b>Does the error message still appear?</b></p>	Go to suspect components	Problem Solved

### 3.66 - Error Message: Call For Service Engine NVR

**The Printer is nearing end of life.**

Logic control on the MCU PWB detected that the printer has processed 450,000 sheets of paper.

Step	Actions and Questions	Yes	No
	<p><b>SUSPECT COMPONENTS</b>                      The following components are associated with this specific problem. One or more of these components may have failed partially or completely. If you cannot isolate the problem using this FIP, replace each component listed below, one at a time, until the problem disappears.</p> <ul style="list-style-type: none"> <li>• Wiring and connectors linking the components</li> </ul>		
<b>1</b>	<p>Go to Section 8 and follow the instructions on how to read the Printer Life Counter and compare that data with any know data regarding the age and usage level of the printer.</p> <p><b>Has the printer engine truly processed at least 450,000 sheets of paper?</b></p>	Deal with the matter according to your company policy	Go to step 2
<b>2</b>	<p><b>MCU/NVRAM STABILITY TEST</b></p> <ol style="list-style-type: none"> <li>1. Write to NVRAM what you believe to be the correct Life Count reading for the printer.</li> <li>2. Generate 100 test prints.</li> <li>3. Reread the Life Counter.</li> </ol> <p><b>Does the Life Counter display the Life Count reading you just entered, plus 100 prints?</b></p>	Treat as an intermittent. If problem reoccurs, replace the MCU PWB (RRP 9.123)	Replace the MCU PWB (RRP 9.123)



### 3.67 - Error Message: BTR2 Life Low

#### BTR2 is nearing end of life.

Logic control on the MCU PWB detected that BTR2 has processed 100,000 sheets of paper.

Step	Actions and Questions	Yes	No
	<p><b>SUSPECT COMPONENTS</b> The following components are associated with this specific problem. One or more of these components may have failed partially or completely. If you cannot isolate the problem using this FIP, replace each component listed below, one at a time, until the problem disappears.</p> <ul style="list-style-type: none"> <li>• Wiring and connectors linking the components</li> </ul>		
<b>1</b>	<p>Go to Section 8 and follow the instructions on how to read the 2ND BTR Life Counter and compare that data with any know data regarding the age and usage level of the current 2ND BTR.</p> <p><b>Has the printer engine truly processed at least 100,000 sheets of paper since the 2ND BTR was last replaced?</b></p>	Deal with the matter according to your company policy or replace the 2nd BTR Assembly (RRP 9.75).	Go to step 2
<b>2</b>	<p><b>MCU/NVRAM STABILITY TEST</b></p> <ol style="list-style-type: none"> <li>1. Write to NVRAM what you believe to be the correct 2ND BTR Life Count reading for the printer.</li> <li>2. Generate 100 test prints.</li> <li>3. Reread the 2ND BTR Life Counter.</li> </ol> <p><b>Does the 2ND BTR Life Counter display the Life Count reading you just entered, plus 100 prints?</b></p>	Treat as an intermittent. If problem reoccurs, replace the MCU PWB (RRP 9.123)	Replace the MCU PWB (RRP 9.123)

### 3.68 - Error Message: Belt Cleaner Life Low

**The Belt Cleaner is nearing end of life.**

Logic control on the MCU PWB detected that the BTR Cleaner processed 100,000 sheets of paper.

Step	Actions and Questions	Yes	No
	<p><b>SUSPECT COMPONENTS</b>                      The following components are associated with this specific problem. One or more of these components may have failed partially or completely. If you cannot isolate the problem using this FIP, replace each component listed below, one at a time, until the problem disappears.</p> <ul style="list-style-type: none"> <li>• Wiring and connectors linking the components</li> </ul>		
<b>1</b>	<p>Go to Section 8 and follow the instructions on how to read the Belt Cleaner Life Counter and compare that data with any know data regarding the age and usage level of the current Belt Cleaner.</p> <p><b>Has the printer engine truly processed at least 100,000 sheets of paper since the Belt Cleaner was last replaced?</b></p>	<p>Deal with the matter according to your company policy or replace the Belt Cleaner Assembly (RRP 9.76).</p>	<p>Go to step 2</p>
<b>2</b>	<p><b>MCU/NVRAM STABILITY TEST</b></p> <ol style="list-style-type: none"> <li>1. Write to NVRAM what you believe to be the correct Belt Cleaner Life Count reading for the printer.</li> <li>2. Generate 100 test prints.</li> <li>3. Reread the Belt Cleaner Life Counter.</li> </ol> <p><b>Does the Belt Cleaner BTR Life Counter display the Life Count reading you just entered, plus 100 prints?</b></p>	<p>Treat as an intermittent. If problem reoccurs, replace the MCU PWB (RRP 9.123)</p>	<p>Replace the MCU PWB (RRP 9.123)</p>

### 3.69 - Error Message: Replace OPC Drum

#### The OPC Drum CRU has reached end of life.

Logic control on the MCU PWB detected that the OPC Drum inside the Print Cartridge has exceeded 90,000 revolutions.

Step	Actions and Questions	Yes	No
	<p><b>SUSPECT COMPONENTS</b> The following components are associated with this specific problem. One or more of these components may have failed partially or completely. If you cannot isolate the problem using this FIP, replace each component listed below, one at a time, until the problem disappears.</p> <ul style="list-style-type: none"> <li>• Wiring and connectors linking the components</li> </ul>		
<b>1</b>	<p>Remove the OPC Drum and inspect the rear of the Cartridge.</p> <p><b>Is there a CRUM Assembly installed at the rear of the Cartridge?</b></p>	<p>Replace the OPC Drum (RRP 9.48). If the problem still appears, replace the MCU PWB (RRP 9.123)</p>	<p>Go to step 2</p>
<b>2</b>	<p>Go to Section 8 and follow the instructions on how to read the OPC Drum Life Counter and compare that data with any know data regarding the age and usage level of the current Cartridge.</p> <p><b>Has the OPC Drum truly processed enough sheets of paper to equal 90,000 revolutions (one revolution for a B/W print and four revolutions for a color print)?</b></p>	<p>Deal with the matter according to your company policy or replace the OPC Drum (RRP 9.48).</p>	<p>Replace the MCU PWB (RRP 9.123)</p>

### 3.70 - Error Message: Fuser Life Low

**The Fuser is nearing end of life.**

Logic control on the MCU PWB detected that the Fuser has been installed while print engine has processed 237,500 images or the print engine has accumulated more than 18.5 hours of toner dispensing time.

Step	Actions and Questions	Yes	No
	<p><b>SUSPECT COMPONENTS</b>                      The following components are associated with this specific problem. One or more of these components may have failed partially or completely. If you cannot isolate the problem using this FIP, replace each component listed below, one at a time, until the problem disappears.</p> <ul style="list-style-type: none"> <li>• Wiring and connectors linking the components</li> </ul>		
<p><b>1</b></p>	<p>Go to Section 8 and follow the instructions on how to read the Main Fuser Life Counter and compare that data with any know data regarding the age and usage level of the current Fuser.</p> <p><b>Has the Main Fuser truly processed at least 237,000 sheets of paper since the it was last replaced?</b></p>	<p>Deal with the matter according to your company policy or replace the Fuser Assembly (RRP 9.80).</p>	<p>Go to step 2</p>
<p><b>2</b></p>	<p><b>MCU/NVRAM STABILITY TEST</b></p> <ol style="list-style-type: none"> <li>1. Write to NVRAM what you believe to be the correct Fuser Life Count reading for the printer.</li> <li>2. Generate 100 test prints.</li> <li>3. Reread the Fuser Life Counter.</li> </ol> <p><b>Does the Fuser BTR Life Counter display the Life Count reading you just entered, plus 100 prints?</b></p>	<p>Treat as an intermittent. If problem reoccurs, replace the MCU PWB (RRP 9.123)</p>	<p>Replace the MCU PWB (RRP 9.123)</p>

### 3.71 - Error Message: Fuser Oil Low

#### The Fuser Oil Roll is nearing end of life.

Logic control on the MCU PWB detected that the Fuser Oil Roll is nearing the 20,000 mark.

Step	Actions and Questions	Yes	No
	<p><b>SUSPECT COMPONENTS</b> The following components are associated with this specific problem. One or more of these components may have failed partially or completely. If you cannot isolate the problem using this FIP, replace each component listed below, one at a time, until the problem disappears.</p> <ul style="list-style-type: none"> <li>• Wiring and connectors linking the components</li> </ul>		
<b>1</b>	<p>Go to Section 8 and follow the instructions on how to read the Oil Roll Life Counter and compare that data with any know data regarding the age and usage level of the current Oil Roll.</p> <p><b>Has the Oil Roll truly processed at least 20,000 sheets of paper since the it was last replaced?</b></p>	Deal with the matter according to your company policy or replace the Oil Roll (RRP 9.82).	Go to step 2
<b>2</b>	<p><b>MCU/NVRAM STABILITY TEST</b></p> <ol style="list-style-type: none"> <li>1. Write to NVRAM what you believe to be the correct Oil Roll Life Count reading for the printer.</li> <li>2. Generate 100 test prints.</li> <li>3. Reread the Oil Roll Counter.</li> </ol> <p><b>Does the Oil Roll Life Counter display the Life Count reading you just entered, plus 100 prints?</b></p>	Treat as an intermittent. If problem reoccurs, replace the MCU PWB (RRP 9.123)	Replace the MCU PWB (RRP 9.123)

### 3.72 - Error Message: Waste Toner Nearly Full

**The Waste Toner Box is almost full.**

Logic control on the MCU PWB detected that the Waste Toner Box is almost full and will soon need to be replaced.

Step	Actions and Questions	Yes	No
	<p><b>SUSPECT COMPONENTS</b>                      The following components are associated with this specific problem. One or more of these components may have failed partially or completely. If you cannot isolate the problem using this FIP, replace each component listed below, one at a time, until the problem disappears.</p> <ul style="list-style-type: none"> <li>• Wiring and connectors linking the components</li> </ul>		
<p><b>1</b></p>	<p>Replace the Waste Toner Box (RRP 9.49).</p> <p><b>Does the error message still appear?</b></p>	<p>Go to step 2</p>	<p>Problem solved</p>
<p><b>2</b></p>	<p>Replace the Waste Toner Sensor (RRP 9.53).</p> <p><b>Does the error message still appear?</b></p>	<p>Replace the MCU PWB (RRP 9.123)</p>	<p>Problem solved</p>

### 3.73 - Error Message: Black Toner Low

#### The Black Toner Cartridge is low on toner.

Logic control on the MCU PWB switched on the Dispense Motor for more than 980 seconds in order to raise the image density to normal.

Step	Actions and Questions	Yes	No
	<p><b>SUSPECT COMPONENTS</b></p> <p>The following components are associated with this specific problem. One or more of these components may have failed partially or completely. If you cannot isolate the problem using this FIP, replace each component listed below, one at a time, until the problem disappears.</p> <ul style="list-style-type: none"> <li>• Wiring and connectors linking the components</li> <li>• Black Developer Assembly (RRP 9.65)</li> <li>• OPC Drum (RRP 9.48)</li> <li>• HVPS (RRP 9.120)</li> </ul>		
<b>1</b>	Replace the Black Toner Cartridge (RRP 9.58). <b>Does the error message still appear?</b>	Go to step 2	Problem solved
<b>2</b>	Replace the Dispense Motor Assembly (RRP 9.116) <b>Does the error message still appear?</b>	Go to step 3	Problem solved
<b>3</b>	Replace the ADC Sensor Assembly (RRP 9.50) <b>Does the error message still appear?</b>	Go to step 4	Problem solved
<b>4</b>	Replace the MCU PWB (RRP 9.123) <b>Does the error message still appear?</b>	Go to suspect components	Problem solved

### 3.74 - Error Message: Cyan Toner Low

**The Cyan Toner Cartridge is low on toner.**

Logic control on the MCU PWB switched on the Dispense Motor for more than 800 seconds in order to raise the image density to normal.

Step	Actions and Questions	Yes	No
	<p><b>SUSPECT COMPONENTS</b>                      The following components are associated with this specific problem. One or more of these components may have failed partially or completely. If you cannot isolate the problem using this FIP, replace each component listed below, one at a time, until the problem disappears.</p> <ul style="list-style-type: none"> <li>• Wiring and connectors linking the components</li> <li>• Cyan Developer Assembly (RRP 9.63)</li> <li>• OPC Drum (RRP 9.48)</li> <li>• HVPS (RRP 9.120)</li> </ul>		
<b>1</b>	Replace the Cyan Toner Cartridge (RRP 9.57).  <b>Does the error message still appear?</b>	Go to step 2	Problem solved
<b>2</b>	Replace the Dispense Motor Assembly (RRP 9.116)  <b>Does the error message still appear?</b>	Go to step 3	Problem solved
<b>3</b>	Replace the ADC Sensor Assembly (RRP 9.50)  <b>Does the error message still appear?</b>	Go to step 4	Problem solved
<b>4</b>	Replace the MCU PWB (RRP 9.123)  <b>Does the error message still appear?</b>	Go to suspect components	Problem solved



### 3.75 - Error Message: Magenta Toner Low

#### The Magenta Toner Cartridge is low on toner.

Logic control on the MCU PWB switched on the Dispense Motor for more than 800 seconds in order to raise the image density to normal.

Step	Actions and Questions	Yes	No
	<p><b>SUSPECT COMPONENTS</b>            The following components are associated with this specific problem. One or more of these components may have failed partially or completely. If you cannot isolate the problem using this FIP, replace each component listed below, one at a time, until the problem disappears.</p> <ul style="list-style-type: none"> <li>• Wiring and connectors linking the components</li> <li>• Magenta Developer Assembly (RRP 9.61)</li> <li>• OPC Drum (RRP 9.48)</li> <li>• HVPS (RRP 9.120)</li> </ul>		
<b>1</b>	Replace the Magenta Toner Cartridge (RRP 9.56).  <b>Does the error message still appear?</b>	Go to step 2	Problem solved
<b>2</b>	Replace the Dispense Motor Assembly (RRP 9.116)  <b>Does the error message still appear?</b>	Go to step 3	Problem solved
<b>3</b>	Replace the ADC Sensor Assembly (RRP 9.50)  <b>Does the error message still appear?</b>	Go to step 4	Problem solved
<b>4</b>	Replace the MCU PWB (RRP 9.123)  <b>Does the error message still appear?</b>	Go to suspect components	Problem solved

### 3.76 - Error Message: Yellow Toner Low

**The Yellow Toner Cartridge is low on toner.**

Logic control on the MCU PWB switched on the Dispense Motor for more than 800 seconds in order to raise the image density to normal.

Step	Actions and Questions	Yes	No
	<p><b>SUSPECT COMPONENTS</b>                      The following components are associated with this specific problem. One or more of these components may have failed partially or completely. If you cannot isolate the problem using this FIP, replace each component listed below, one at a time, until the problem disappears.</p> <ul style="list-style-type: none"> <li>• Wiring and connectors linking the components</li> <li>• Yellow Developer Assembly (RRP 9.59)</li> <li>• OPC Drum (RRP 9.48)</li> <li>• HVPS (RRP 9.120)</li> </ul>		
<b>1</b>	Replace the Yellow Toner Cartridge (RRP 9.55).  <b>Does the error message still appear?</b>	Go to step 2	Problem solved
<b>2</b>	Replace the Dispense Motor Assembly (RRP 9.116)  <b>Does the error message still appear?</b>	Go to step 3	Problem solved
<b>3</b>	Replace the ADC Sensor Assembly (RRP 9.50)  <b>Does the error message still appear?</b>	Go to step 4	Problem solved
<b>4</b>	Replace the MCU PWB (RRP 9.123)  <b>Does the error message still appear?</b>	Go to suspect components	Problem solved

## **Section 4 - Primary FIPs: Printer Performance Problems**

---

## **Contents**

<b>Printer Performance Problem Flow Chart</b> .....	4-3
4.1 Inoperative Printer .....	4-4
4.2 Erratic Printer Operation .....	4-6

## **4 - Printer Performance Problem FIPs**

### **Before entering the Printer Performance Problems FIPs:**

1. Is the printer plugged into a recommended AC wall outlet?
2. Is the AC power provided at the wall outlet within recommended specifications?
3. Is the AC power cord connected to the printer.
4. Is the AC power cord in good condition; not frayed or broken?
5. Is the printer properly grounded through the AC wall outlet?
6. Is the printer located in an area where the temperature and humidity are moderate and stable?
7. Is the printer located in an area that is free of dust?
8. Is the printer located in an area away from water outlets, steamers, electric heaters, volatile gases, or open flames?
9. Is the printer shielded from the direct rays of the sun?
10. Does the printer have recommended space around all sides for proper ventilation?
11. Is the printer sitting on a level and stable surface?
12. Is recommended paper stock being used in the printer?
13. Does the customer use the printer as instructed in the User Manual?
14. Are consumables replaced at recommended intervals?
15. Do you have access to QMS Engine Diagnostic menus and do you know how to use them?

### Printer Performance Problem Flow Chart

The FIP Flowchart should have directed you to this section. Start at your problem box, then follow the arrow leading to the individual FIP that corresponds to that problem. Primary FIPs may direct you to a Secondary FIP. In the Performance Problems Flowchart, the relationship between Primary and Secondary FIPs is represented by dotted lines

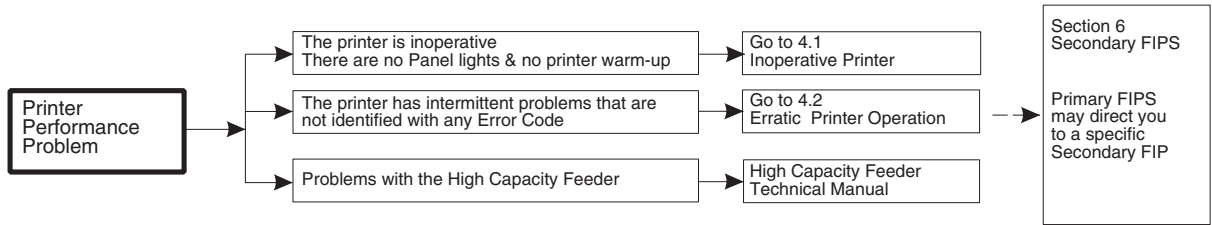

### 4.1 - Inoperative Printer

When you switch on the printer, the Control Panel does not light, the Fans do not rotate, the Rotary Motor does not cycle, and the printer does not go into warm-up.

Step	Actions and Questions	Yes	No
	<p><b>SUSPECT COMPONENTS</b>                      The following components are associated with this specific problem. One or more of these components may have failed partially or completely. If you cannot isolate the problem using this FIP, replace each component listed below, one at a time, until the problem disappears.</p> <ul style="list-style-type: none"> <li>• Interlock switches and circuits</li> <li>• Wiring and connectors linking the components</li> </ul>		
<b>1</b>	<p><b>ERROR MESSAGE OR FAILURE DISPLAYED</b>                      Enter Diagnostics and check for a displayed error or failure. Refer to Section 7 on how to use the diagnostics to check for errors or failures.</p> <p><b>Does diagnostics display a failure?</b></p>	Go to Section 3 to resolve errors or failures	Go to step 2
<b>2</b>	<p><b>LVPS 110VAC IN CHECK</b></p> <ol style="list-style-type: none"> <li>1. Remove the Rear Cover (RRP 9.4).</li> <li>2. Measure the voltage between the two LVPS PWB solder points that are located next to the AC Power Jack.</li> </ol> <p><b>Is there 110VAC between the two points?</b></p>	Go to step 5	Go to step 3
<b>3</b>	<p><b>AC POWER CORD INSPECTION</b>                      Inspect the AC Power Cord.</p> <p><b>Is the AC Power Cord plugged into the printer, and is the other end plugged into an AC wall outlet?</b></p>	Go to step 4	Plug the AC Power Cord into the printer and into an AC wall outlet
<b>4</b>	<p><b>AC POWER CHECK</b>                      Check the voltage at the AC wall outlet.</p> <p><b>Is there approximately 110VAC (or 220VAC if the printer is the 220VAC model) at the AC wall outlet?</b></p>	Go to step 5	Troubleshoot the AC power at the wall outlet
<b>5</b>	<p><b>LVPS +5VDC CHECK</b></p> <ol style="list-style-type: none"> <li>1. Remove the Rear Cover (RRP 9.4)</li> <li>2. Measure the voltage between P33-3 on the LVPS and Frame Ground.</li> </ol> <p><b>Is there +5VDC between P33-3 and Frame Ground.</b></p>	Go to step 6	Go to step 9
<b>6</b>	<p><b>LVPS +24VDC CHECK</b></p> <ol style="list-style-type: none"> <li>1. Remove the Rear Cover (RRP 9.4)</li> <li>2. Measure the voltage between P32-11 on the LVPS and Frame Ground.</li> </ol> <p><b>Is there +24VDC between P32-11 and Frame Ground.</b></p>	Go step 7	Go to step 9

**4.1 - Inoperative Printer, continued**

<b>Step</b>	<b>Actions and Questions</b>	<b>Yes</b>	<b>No</b>
<b>7</b>	<b>CONTROLLER PWB CHECK</b> 1. Switch off the Main Switch. 2. Remove the Controller PWB (RRP 9.129). 3. Switch on the Main Switch. <b>Does the printer go into warm-up?</b>	Replace the Controller PWB (9.129) with a new one	Go to step 8
<b>8</b>	Replace the MCU PWB (RRP 9.123) <b>Does the printer go into warm-up?</b>	Problem solved	Go to step 9
<b>9</b>	<b>LVPS LOADING CHECK</b> 1. Disconnect P35 from the LVPS. 2. Measure the voltage between P33-3 on the LVPS and Frame Ground, and between P32-11 on the LVPS and Frame Ground. <b>Is there +5VDC between P33-3 and Frame Ground, and is there +24VDC between P32-11 and Frame Ground?</b>	Replace the Fuser Assembly (RRP 9.80)	Go to step 10
<b>10</b>	<b>LVPS LOADING CHECK</b> 1. Disconnect P32 and P33 from the LVPS. 2. Measure the voltage between P33-3 on the LVPS and Frame Ground, and between P32-11 on the LVPS and Frame Ground. <b>Is there +5VDC between P33-3 and Frame Ground, and is there +24VDC between P32-11 and Frame Ground?</b>	Go to step 11	Replace the LVPS (RRP 9.119)
<b>11</b>	<b>MCU PWB LOADING CHECK</b> 1. Reconnect P32 and P33 to the LVPS. 2. Refer to Section 12 Wiring Diagrams and one by one disconnect components that are connected to the MCU PWB. 3. Measure the voltage between P33-3 on the LVPS and Frame Ground, and between P32-11 on the LVPS and Frame Ground. <b>Do you eventually measure +5VDC between P33-3 and Frame Ground, and +24VDC between P32-11 and Frame Ground?</b>	Replace the component that loads down the LVPS.	Replace the MCU PWB (RRP 9.123)

## 4.2 - Erratic Printer Operation

The printer has a variety of intermittent problems, but generally does not complete a print cycle. The problems are generally not identified by displayed error messages.

Step	Actions and Questions	Yes	No
	<p><b>SUSPECT COMPONENTS</b>                      The following components are associated with this specific problem. One or more of these components may have failed partially or completely. If you cannot isolate the problem using this FIP, replace each component listed below, one at a time, until the problem disappears.</p> <ul style="list-style-type: none"> <li>• Interlock switches and circuits</li> <li>• Components connected to the MCU PWB</li> <li>• Wiring and connectors linking the components</li> </ul>		
<b>1</b>	<p><b>Does the printer frequently fail to enter printer warm-up or is the Control Panel frequently inoperative?</b></p>	Go to FIP 4.1 Inoperative Printer	Go to step 2
<b>2</b>	<p><b>LVPS LOADING CHECK</b>                      1. Run 50 Test Prints.                      2. Measure the voltage between P33-3 on the LVPS and Frame Ground, and between P32-11 on the LVPS and Frame Ground.  <b>Is there a steady +5VDC between P33-3 and Frame Ground, and is there at steady +24VDC between P32-11 and Frame Ground?</b></p>	Go to step 3	Replace the LVPS (RRP 9.119)
<b>3</b>	<p><b>HOST SOFTWARE REPLACEMENT</b>                      Reload the System Software (OS) or Application Software on the host side.  <b>Does the printer still exhibit erratic operation?</b></p>	Go to step 4	Problem solved
<b>4</b>	<p><b>HOST/PRINTER INTERFACE CABLE REPLACEMENT</b>                      Replace the interface cable connecting the host to the printer.  <b>Is the problem still present?</b></p>	Go to step 5	Problem solved
<b>5</b>	<p>Replace the MCU PWB (RRP 9.123)  <b>Does the problem still appear?</b></p>	Go to step 6	Problem solved
<b>6</b>	<p>Replace the Controller PWB (RRP 9.129)  <b>Does the printer still exhibit erratic operation?</b></p>	Go to FIP 6.1 Electrical Noise	Problem solved



**Section 5 - Primary FIPs: Image Quality****Contents**

The Use of Diagnostics Test Print .....	5-5
5.1 Light (Undertoned) Prints .....	5-6
5.2 Blank Prints .....	5-8
5.3 Black Prints .....	5-10
5.4 Vertical Band Deletions .....	5-12
5.5 Horizontal Band Deletions .....	5-14
5.6 Vertical Streaks .....	5-16
5.7 Horizontal Streaks .....	5-18
5.8 Spot Deletions .....	5-20
5.9 Spots .....	5-22
5.10 Residual Image or Ghosting .....	5-24
5.11 Background .....	5-26
5.12 Toner on Back of Print .....	5-28
5.13 Skewed Image .....	5-30
5.14 Damaged Prints .....	5-32
5.15 Unfused Image or Image Easily Rubs Off of Page .....	5-33
5.16 A Repetitive Mark Appears on Each Print .....	5-36
5.17 The Printed Image is Mottled .....	5-37
5.18 Image Not Registered Correctly on the Page .....	5-38
5.19 Color Layers are not Registered Correctly .....	5-39
5.20 Color Representation Not Correct .....	5-40

## 5-Image Quality FIPs

### Before entering the Image Quality FIPs:

1. **Does the printer display an error message? If so, go to Section 2 FIP Flowchart and start troubleshooting there.**
2. Is the AC power provided at the wall outlet within recommended specifications?
3. Is the printer properly grounded through the AC wall outlet?
4. Is the printer located in an area where the temperature and humidity are moderate and stable?
5. Is the printer located in an area that is free of dust?
6. Is the printer located in an area away from water outlets, steamers, electric heaters, volatile gases, or open flames?
7. Is the printer shielded from the direct rays of the sun?
8. Does the printer have recommended space around all sides for proper ventilation?
9. Is the printer on a level and stable surface?
10. Is recommended paper stock being used in the printer?
11. Does the customer use the printer as instructed in the User Manual?
12. Have consumables been replaced at the recommended intervals?
13. Do you have access to QMS Engine Diagnostic menus and do you know how to use them?
14. Are all of the printer assemblies in place and are all of printer covers and doors firmly closed?

## The Use of Diagnostics TestPrint

Image Quality FIPs may ask you to generate a Test Print to help isolate the cause of an image quality problem. Follow the instructions in each FIP to evaluate the Test Print.

If the printer can generate a normal Test Print on request, then the Controller PWB, the host software, or the interface cable between the printer and the host computer is most likely the cause of the image quality problem.

### To Generate a Test Print.

1. Remove Right Cover Assembly (RRP 9.8).
2. Remove the Controller PWB (RRP 9.129) so you can access the MCU PWB.
3. Remove the access panel beneath the Controller PWB.
4. At the PJ3 location you will find a switch. Move the PJ3 switch to the "ON" position.
5. Switch on printer main power.
6. The printer generates process black (all four colors layered) grid patterns.
7. The printer feeds from the first tray that has paper - in this order; Tray 1, Tray 2, Tray 3, Tray 4, and MSI. The printer sends the test prints to the Face Down Output Tray.
8. The printer generates test prints until you stop the test. To stop generating test prints, move the switch to the "1" position.

**NOTE**

*Image Quality FIPs often ask you to stop the printer at a specific point in the print cycle; such as "before the paper reaches the Fuser". You may have to use trial and error until you are able to stop the print cycle at the exact point requested.*

## 5.1 - Light (Undertoned) Prints

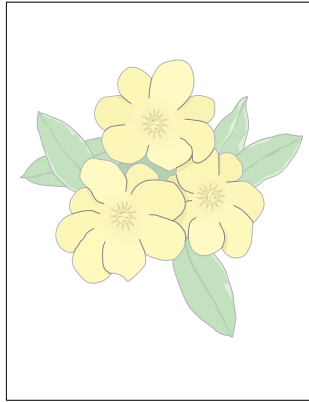

RS500X

### PROBLEM

The overall image density is too light. The image may also be unfused due to insufficient image density. **THE PRINTER DISPLAYS NO ERROR MESSAGE.**

### SUSPECT COMPONENTS

The following components are associated with this specific problem. One or more of these components may have failed partially or completely. If you cannot isolate the problem using this FIP, replace each component listed below, one at a time, until the problem disappears.

- **MCU PWB (RRP 9.123)**
- **Xerographic Cartridge (RRP 9.48)**
- **ADC Sensor Assembly (RRP 9.50)**
- **Toner Cartridges**
- **ROS Assembly (RRP 9.47)**

Step	Actions and Questions	Yes	No
1	<b>PAPER INSPECTION</b> Inspect the paper that is loaded in the paper tray. <b>Is the paper wrinkled, dimpled, or show any sign of having a high moisture content?</b>	Load fresh, dry paper.	Go to step 2
2	<b>2ND TRANSFER IMAGE INSPECTION</b> 1. Generate a test print and slide the Fuser Assembly out of the printer just as the sheet of paper starts to exit the Fuser. 2. Inspect the image on the sheet of paper <u>before</u> it reached the Fuser Rolls. <b>Is the image density normal before it reached the Fuser Rolls?</b>	Go to step 6	Go to step 3
3	<b>1ST IMAGE TRANSFER INSPECTION</b> 1. Remove the Xerographic Cartridge (RRP 9.48). 2. Inspect the test print image on the IBT. <b>Is the image on the IBT appear completely transferred and are the grid lines black and unbroken?</b>	Go to step 4	Go to step 5
4	1. Replace the 2nd BTR Assembly (RRP 9.75). 2. Generate a test print. 3. Inspect the image on the sheet of paper. <b>Is the image density now normal?</b>	Problem Solved	Replace the HVPS (RRP 9.120)
5	1. Replace the Transfer Assembly (RRP 9.71). 2. Generate a test print. 3. Inspect the image on the sheet of paper. <b>Is the image density now normal?</b>	Problem Solved	Replace the HVPS (RRP 9.120)

**5.1 - Light (Undertoned) Prints, continued**

<b>Step</b>	<b>Actions and Questions</b>	<b>Yes</b>	<b>No</b>
6	<b>FUSER INSPECTION</b> Inspect the image on the sheet of paper <u>after</u> it exits the Fuser Rolls. <b>Is the image light when it exits the Fuser?</b>	Go to step 7	
7	1. Replace the Oil Roll Assembly (RRP 9.82). 2. Generate a dozen test print. 3. Inspect the image on the last sheet out. <b>Is the image density now normal as it exits the Fuser?</b>	Problem Solved	Replace the Pressure Roll (RRP 9.83) and the Heat Roll (RRP 9.84)

## 5.2 - Blank Prints

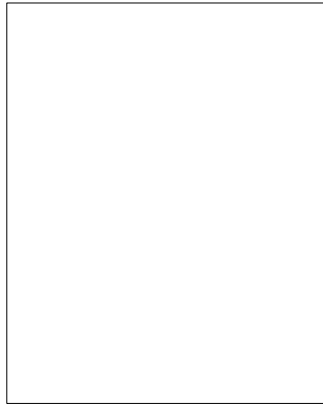

RS501X

### PROBLEM

The entire image area is blank. **THE PRINTER DISPLAYS NO ERROR MESSAGE.**

### SUSPECT COMPONENTS

The following components are associated with this specific problem. One or more of these components may have failed partially or completely. If you cannot isolate the problem using this FIP, replace each component listed below, one at a time, until the problem disappears.

- **MCU PWB (RRP 9.123)**
- **LVPS (RRP 9.119)**
- **ROS Assembly (RRP 9.47)**

Step	Actions and Questions	Yes	No
1	<p><b>CONTROLLER OR HOST SOFTWARE ISOLATION</b> Generate a test print.</p> <p><b>Is the test print blank?</b></p>	Go to step 2	Reload the driver software or replace the Controller PWB (RRP 9.129)
2	<p><b>LASER PATH INSPECTION</b></p> <ol style="list-style-type: none"> <li>1. Remove the Xerographic Cartridge (RRP 9.48).</li> <li>2. Inspect the empty Xerographic Cartridge cavity for a sheet of paper that could be blocking the ROS window.</li> </ol> <p><b>Is there a sheet of paper blocking the ROS window?</b></p>	Remove the sheet of paper	Go to step 3
3	<p><b>XEROGRAPHIC INSPECTION</b></p> <ol style="list-style-type: none"> <li>1. Generate a test print and slide the Fuser Assembly out of the printer just before the sheet of paper enters the Fuser.</li> <li>2. Remove the Xerographic Cartridge (RRP 9.48).</li> <li>3. Inspect the image on the Drum.</li> </ol> <p><b>Is there a developed image visible on the drum?</b></p>	Go to step 5	Go to step 4
4	<ol style="list-style-type: none"> <li>1. Replace the Xerographic Cartridge (RRP 9.48).</li> <li>2. Generate a test print.</li> </ol> <p><b>Is the test print blank?</b></p>	Replace the HVPS (RRP 9.120)	Problem solved
5	<p><b>IBT INSPECTION</b> Inspect the image on the surface of the IBT?</p> <p><b>Is there a developed image visible on the surface of the IBT?</b></p>	Go to step 6	Go to step 7

### 5.2 - Blank Prints, continued

<b>Step</b>	<b>Actions and Questions</b>	<b>Yes</b>	<b>No</b>
6	1. Replace the 2ND BTR Assembly (RRP 9.75). 2. Generate a test print. <b>Is the test print blank?</b>	Replace the HVPS (RRP 9.120)	Problem solved
7	1. Replace the Transfer Assembly (RRP 9.71). 2. Generate a test print. <b>Is the test print blank?</b>	Replace the HVPS (RRP 9.120)	Problem solved

### 5.3 - Black Prints

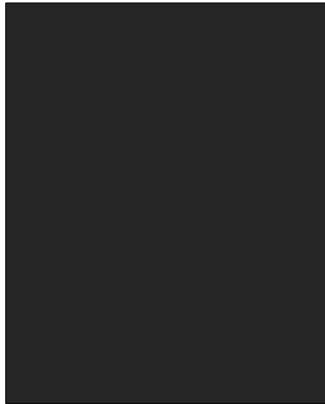

**PROBLEM**

The entire image area is black. **THE PRINTER DISPLAYS NO ERROR MESSAGE.**

**SUSPECT COMPONENTS**

The following components are associated with this specific problem. One or more of these components may have failed partially or completely. If you cannot isolate the problem using this FIP, replace each component listed below, one at a time, until the problem disappears.

- **MCU PWB (RRP 9.123)**
- **LVPS (RRP 9.119)**
- **ROS Assembly (RRP 9.47)**

RS502X

Step	Actions and Questions	Yes	No
1	<p><b>CONTROLLER OR HOST SOFTWARE ISOLATION</b> Generate a test print.</p> <p><b>Is the test print completely black?</b></p>	Go to step 2	Reload the host driver software or replace the Controller PWB (RRP 9.129)
2	<p><b>XEROGRAPHIC INSPECTION</b></p> <ol style="list-style-type: none"> <li>1. Generate a test print and slide the Fuser Assembly out of the printer just before the sheet of paper enters the Fuser.</li> <li>2. Remove the Xerographic Cartridge (RRP 9.48).</li> <li>3. Inspect the image on the Drum.</li> </ol> <p><b>Is there a normal test print image visible on the drum?</b></p>	Go to step 4	Go to step 3
3	<ol style="list-style-type: none"> <li>1. Replace the Xerographic Cartridge (RRP 9.48).</li> <li>2. Generate a test print.</li> </ol> <p><b>Is the test print completely black?</b></p>	Replace the HVPS (RRP 9.120)	Problem solved
4	<p><b>IBT INSPECTION</b> Inspect the image on the surface of the IBT?</p> <p><b>Is there a normal test print image visible on the surface of the IBT?</b></p>	Go to step 5	Go to step 6



**5.3 - Black Prints, continued**

<b>Step</b>	<b>Actions and Questions</b>	<b>Yes</b>	<b>No</b>
<b>5</b>	1. Replace the 2ND BTR Assembly (RRP 9.75). 2. Generate a test print. <b>Is the test print completely black?</b>	Replace the HVPS (RRP 9.120)	Problem solved
<b>6</b>	1. Replace the Transfer Assembly (RRP 9.71). 2. Generate a test print. <b>Is the test print completely black?</b>	Replace the HVPS (RRP 9.120)	Problem solved

## 5.4 - Vertical Band Deletions

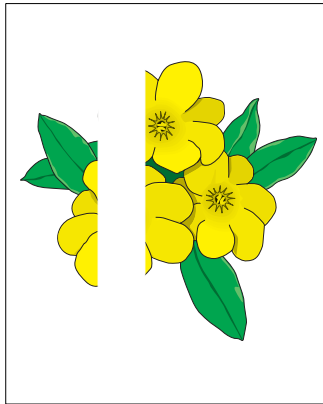

### PROBLEM

There are areas of the image that are extremely light or are missing entirely. These missing areas form wide bands that run vertically along the page in the direction of paper travel. **THE PRINTER DISPLAYS NO ERROR MESSAGE.**

### SUSPECT COMPONENTS

The following components are associated with this specific problem. One or more of these components may have failed partially or completely. If you cannot isolate the problem using this FIP, replace each component listed below, one at a time, until the problem disappears.

- **MCU PWB (RRP 9.123)**
- **LVPS (RRP 9.119)**
- **ROS Assembly (RRP 9.47)**

RS503X

Step	Actions and Questions	Yes	No
1	<b>PAPER INSPECTION</b> Inspect the paper that is loaded in the paper tray. <b>Is the paper wrinkled, dimpled, or show any signs of having a high moisture content?</b>	Load fresh, dry paper.	Go to step 2
2	<b>LASER PATH INSPECTION</b> 1. Remove the Xerographic Cartridge (RRP 9.48). 2. Inspect the empty Xerographic Cartridge cavity for a scrap of paper or a toner blotch that could be blocking the ROS window. <b>Is there debris blocking the ROS window?</b>	Remove the debris from the ROS window	Go to step 3
3	<b>XEROGRAPHIC INSPECTION</b> 1. Generate a test print and slide the Fuser Assembly out of the printer just before the sheet of paper enters the Fuser. 2. Remove the Xerographic Cartridge (RRP 9.48). 3. Inspect the image on the Drum. <b>Is there a normal test print image, without any vertical band deletions, visible on the Drum?</b>	Go to step 5	Go to step 4
4	<b>DEVELOPER ASSEMBLY INSPECTION</b> 1. Remove the Top Cover (RRP 9.3). 2. Turn the Rotary Frame and inspect the Magnet Roll of each of the four Developer Assemblies. <b>Do the Magnet Rolls of each Developer Assembly appear smooth, evenly formed, without any low spots, and without obvious contamination?</b>	Replace the Xerographic Cartridge (RRP 9.48)	Replace the faulty Developer Assembly

### 5.4 - Vertical Band Deletions, continued

Step	Actions and Questions	Yes	No
5	<b>IBT INSPECTION</b> Inspect the image on the surface of the IBT?  <b>Is there a normal test print image, without any vertical band deletions, visible on the surface of the IBT?</b>	Go to step 6	Replace the Transfer Assembly (RRP 9.71)
6	<b>2ND TRANSFER INSPECTION</b> 1. Generate a test print and slide the Fuser Assembly out of the printer just before the sheet of paper enters the Fuser. 2. Inspect the image on the sheet of paper just before the paper enter the Fuser.  <b>Is there a normal test print image, without any vertical band deletions, visible on the sheet of paper?</b>	Go to step 7	Replace the 2ND BTR Assembly (RRP 9.75)
7	<b>FUSER INSPECTION</b> 1. Generate a test print and slide the Fuser Assembly out of the printer just as the sheet of paper exits the Fuser. 2. Inspect the image on the sheet of paper just after the paper exits the Fuser.  <b>Is there a normal test print image on the sheet of paper before entering the Fuser but the image has visible vertical band deletions after it exits the Fuser?</b>	Go to step 8	
8	1. Replace the Oil Roll Assembly (RRP 9.82). 2. Generate a test print. 3. Inspect the image on the sheet.  <b>Is the image now normal, without vertical band deletions as it exits the Fuser?</b>	Problem Solved	Replace the Pressure Roll (RRP 9.83) and the Heat Roll (RRP 9.84)

## 5.5 - Horizontal Band Deletions

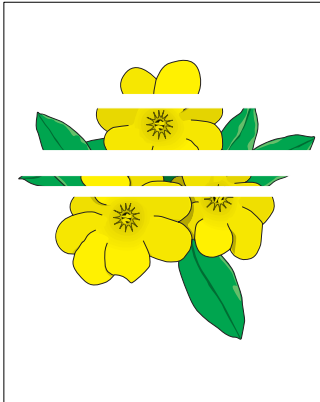

RS504X

### PROBLEM

There are areas of the image that are extremely light or are missing entirely. These missing areas form wide bands that run horizontally across the page parallel with the direction of paper travel. **THE PRINTER DISPLAYS NO ERROR MESSAGE.**

### SUSPECT COMPONENTS

The following components are associated with this specific problem. One or more of these components may have failed partially or completely. If you cannot isolate the problem using this FIP, replace each component listed below, one at a time, until the problem disappears.

- **MCU PWB (RRP 9.123)**
- **LVPS (RRP 9.119)**
- **ROS Assembly (RRP 9.47)**
- **Developer Clutch Assembly (RRP 9.117)**
- **Components shorting to the printer frame**

Step	Actions and Questions	Yes	No
1	<p><b>PAPER INSPECTION</b></p> <p>Inspect the paper that is loaded in the paper tray.</p> <p><b>Is the paper wrinkled, dimpled, or show any signs of having a high moisture content?</b></p>	Load fresh, dry paper.	Go to step 2
2	<p><b>XEROGRAPHIC INSPECTION</b></p> <ol style="list-style-type: none"> <li>1. Generate a test print and slide the Fuser Assembly out of the printer just before the sheet of paper enters the Fuser.</li> <li>2. Remove the Xerographic Cartridge (RRP 9.48).</li> <li>3. Inspect the image on the Drum.</li> </ol> <p><b>Is there a normal test print image, without any horizontal band deletions, visible on the drum?</b></p>	Go to step 3	Go to step 7
3	<p><b>IBT INSPECTION</b></p> <p>Inspect the image on the surface of the IBT?</p> <p><b>Is there a normal test print image, without any horizontal band deletions, visible on the surface of the IBT?</b></p>	Go to step 4	Replace the Transfer Assembly (RRP 9.71)
4	<p><b>2ND TRANSFER INSPECTION</b></p> <ol style="list-style-type: none"> <li>1. Generate a test print and slide the Fuser Assembly out of the printer just before the sheet of paper enters the Fuser.</li> <li>2. Inspect the image on the sheet of paper just before the paper enter the Fuser.</li> </ol> <p><b>Is there a normal test print image, without any horizontal band deletions, visible on the sheet of paper?</b></p>	Go to step 5	Replace the 2ND BTR Assembly (RRP 9.75)

**5.5 - Horizontal Band Deletions, continued**

Step	Actions and Questions	Yes	No
5	<p><b>FUSER INSPECTION</b></p> <ol style="list-style-type: none"> <li>1. Generate a test print and slide the Fuser Assembly out of the printer just as the sheet of paper exits the Fuser.</li> <li>2. Inspect the image on the sheet of paper just after the paper exits the Fuser.</li> </ol> <p><b>Is there a normal test print image on the sheet of paper before entering the Fuser but the image has visible horizontal band deletions after it exits the Fuser?</b></p>	Go to step 6	
6	<ol style="list-style-type: none"> <li>1. Replace the Oil Roll Assembly (RRP 9.82).</li> <li>2. Generate a test print.</li> <li>3. Inspect the image on the sheet.</li> </ol> <p><b>Is the image now normal, without horizontal band deletions as it exits the Fuser?</b></p>	Problem Solved	Replace the Pressure Roll (RRP 9.83) and the Heat Roll (RRP 9.84)
7	<ol style="list-style-type: none"> <li>1. Replace the Xerographic Cartridge (RRP 9.48).</li> <li>2. Generate a test print.</li> </ol> <p><b>Is the image now normal, without horizontal band deletions?</b></p>	Problem solved	Go to step 8
8	<p><b>DEVELOPER ASSEMBLY INSPECTION</b></p> <ol style="list-style-type: none"> <li>1. Remove the Top Cover (RRP 9.3).</li> <li>2. Turn the Rotary Frame and inspect the Magnet Roll of each of the four Developer Assemblies.</li> </ol> <p><b>Do the Magnet Rolls of each Developer Assembly appear smooth, evenly formed, without any low spots, and without obvious contamination?</b></p>	Go to step 9	Replace the faulty Developer Assembly
9	<ol style="list-style-type: none"> <li>1. Replace the HVPS (RRP 9.120).</li> <li>2. Generate a test print.</li> </ol> <p><b>Is the image now normal, without horizontal band deletions?</b></p>	Problem solved	Go to step 10
10	<ol style="list-style-type: none"> <li>1. Replace each of the four Developer Assemblies, one at a time.</li> <li>2. Generate a test print each time you replace a Developer Assembly.</li> </ol> <p><b>Is the image now normal, without horizontal band deletions?</b></p>	Problem solved	Go Suspect Components

## 5.6 - Vertical Streaks

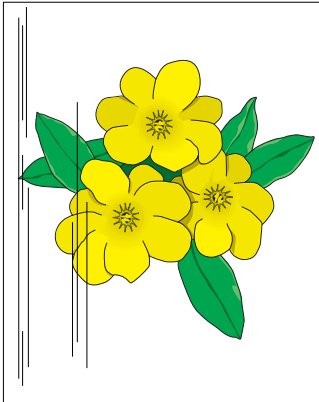

RS506X

### PROBLEM

There are black lines running vertically along the page. **THE PRINTER DISPLAYS N ERROR MESSAGE.**

### SUSPECT COMPONENTS

The following components are associated with this specific problem. One or more of these components may have failed partially or completely. If you cannot isolate the problem using this FIP, replace each component listed below, one at a time, until the problem disappears.

- **MCU PWB (RRP 9.123)**
- **LVPS (RRP 9.119)**
- **ROS Assembly (RRP 9.47)**

Step	Actions and Questions	Yes	No
1	<p><b>PAPER PATH INSPECTION</b></p> <p>Inspect the paper path, between feed and exit, for contamination or obstructions.</p> <p><b>Is the paper path free of contamination or obstructions?</b></p>	Go to step 2	Clear the paper path
2	<p><b>XEROGRAPHIC INSPECTION</b></p> <ol style="list-style-type: none"> <li>1. Generate a test print and slide the Fuser Assembly out of the printer just before the sheet of paper enters the Fuser.</li> <li>2. Remove the Xerographic Cartridge (RRP 9.48).</li> <li>3. Inspect the image on the Drum.</li> </ol> <p><b>Is there a normal test print image, without any vertical streaks, visible on the drum?</b></p>	Go to step 3	Go to step 7
3	<p><b>IBT INSPECTION</b></p> <p>Inspect the image on the surface of the IBT?</p> <p><b>Is there a normal test print image, without any vertical streaks, visible on the surface of the IBT?</b></p>	Go to step 4	Replace the Transfer Assembly (RRP 9.71)
4	<p><b>2ND TRANSFER INSPECTION</b></p> <ol style="list-style-type: none"> <li>1. Generate a test print and slide the Fuser Assembly out of the printer just before the sheet of paper enters the Fuser.</li> <li>2. Inspect the image on the sheet of paper just before the paper enter the Fuser.</li> </ol> <p><b>Is there a normal test print image, without any vertical streaks, visible on the sheet of paper?</b></p>	Go to step 5	Replace the 2ND BTR Assembly (RRP 9.75)

**5.6 - Vertical Streaks, continued**

Step	Actions and Questions	Yes	No
5	<p><b>FUSER INSPECTION</b></p> <ol style="list-style-type: none"> <li>1. Generate a test print and slide the Fuser Assembly out of the printer just as the sheet of paper exits the Fuser.</li> <li>2. Inspect the image on the sheet of paper just after the paper exits the Fuser.</li> </ol> <p><b>Is there a normal test print image on the sheet of paper before entering the Fuser but the image has visible vertical streaks after it exits the Fuser?</b></p>	Go to step 6	
6	<ol style="list-style-type: none"> <li>1. Replace the Oil Roll Assembly (RRP 9.82).</li> <li>2. Generate a test print.</li> <li>3. Inspect the image on the sheet.</li> </ol> <p><b>Is the image now normal, without vertical streaks as it exits the Fuser?</b></p>	Problem Solved	Replace the Pressure Roll (RRP 9.83) and the Heat Roll (RRP 9.84)
7	<ol style="list-style-type: none"> <li>1. Replace the Xerographic Cartridge (RRP 9.48).</li> <li>2. Generate a test print.</li> </ol> <p><b>Is the image now normal, without vertical streaks?</b></p>	Problem solved	Go to step 8
8	<p><b>DEVELOPER ASSEMBLY INSPECTION</b></p> <ol style="list-style-type: none"> <li>1. Remove the Top Cover (RRP 9.3).</li> <li>2. Turn the Rotary Frame and inspect the Magnet Roll of each of the four Developer Assemblies.</li> </ol> <p><b>Do the Magnet Rolls of each Developer Assembly appear smooth, evenly formed and without obvious contamination?</b></p>	Go Suspect Components	Replace the faulty Developer Assembly

### 5.7 - Horizontal Streaks

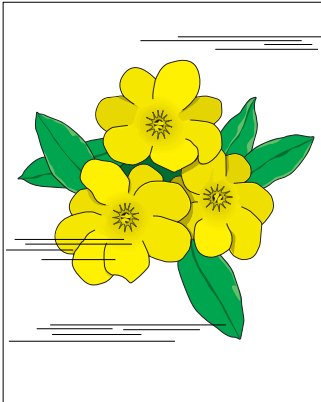

RS507X

#### PROBLEM

There are black lines running horizontally across the paper. **THE PRINTER DISPLAYS NO ERROR MESSAGE.**

#### SUSPECT COMPONENTS

The following components are associated with this specific problem. One or more of these components may have failed partially or completely. If you cannot isolate the problem using this FIP, replace each component listed below, one at a time, until the problem disappears.

- **MCU PWB (RRP 9.123)**
- **Controller PWB (RRP 9.129)**
- **LVPS (RRP 9.119)**
- **ROS Assembly (RRP 9.47)**

Step	Actions and Questions	Yes	No
1	<p><b>XEROGRAPHIC INSPECTION</b></p> <ol style="list-style-type: none"> <li>1. Generate a test print and slide the Fuser Assembly out of the printer just before the sheet of paper enters the Fuser.</li> <li>2. Remove the Xerographic Cartridge (RRP 9.48).</li> <li>3. Inspect the image on the Drum.</li> </ol> <p><b>Is there a normal test print image, without any horizontal streaks, visible on the drum?</b></p>	Go to step 2	Go to step 6
2	<p><b>IBT INSPECTION</b></p> <p>Inspect the image on the surface of the IBT?</p> <p><b>Is there a normal test print image, without any horizontal streaks, visible on the surface of the IBT?</b></p>	Go to step 3	Replace the Transfer Assembly (RRP 9.71)
3	<p><b>2ND TRANSFER INSPECTION</b></p> <ol style="list-style-type: none"> <li>1. Generate a test print and slide the Fuser Assembly out of the printer just before the sheet of paper enters the Fuser.</li> <li>2. Inspect the image on the sheet of paper just before the paper enter the Fuser.</li> </ol> <p><b>Is there a normal test print image, without any horizontal streaks, visible on the sheet of paper?</b></p>	Go to step 4	Replace the 2ND BTR Assembly (RRP 9.75)
4	<p><b>FUSER INSPECTION</b></p> <ol style="list-style-type: none"> <li>1. Generate a test print and slide the Fuser Assembly out of the printer just as the sheet of paper exits the Fuser.</li> <li>2. Inspect the image on the sheet of paper just after the paper exits the Fuser.</li> </ol> <p><b>Is there a normal test print image on the sheet of paper before entering the Fuser but the image has visible horizontal streaks after it exits the Fuser?</b></p>	Go to step 5	



**5.7 - Horizontal Streaks, continued**

Step	Actions and Questions	Yes	No
5	1. Replace the Oil Roll Assembly (RRP 9.82). 2. Generate a test print. 3. Inspect the image on the sheet. <b>Is the image now normal, without horizontal streaks as it exits the Fuser?</b>	Problem Solved	Replace the Pressure Roll (RRP 9.83) and the Heat Roll (RRP 9.84)
6	1. Replace the Xerographic Cartridge (RRP 9.48). 2. Generate a test print. <b>Is the image now normal, without vertical streaks?</b>	Problem solved	Go to step 7
7	<b>DEVELOPER ASSEMBLY INSPECTION</b> 1. Remove the Top Cover (RRP 9.3). 2. Turn the Rotary Frame and inspect the Magnet Roll of each of the four Developer Assemblies. <b>Do the Magnet Rolls of each Developer Assembly appear smooth, evenly formed and without obvious contamination?</b>	Go Suspect Components	Replace the faulty Developer Assembly

## 5.8 - Spot Deletions

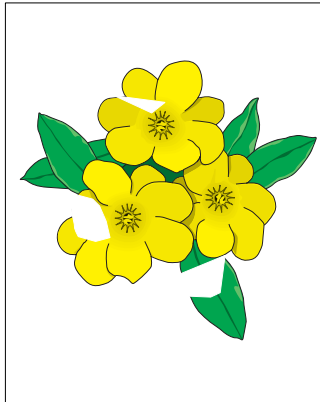

RS508X

### PROBLEM

There are areas of the image that are extremely light or are missing entirely. These missing areas form spots that are localized to small areas of the page. **THE PRINTER DISPLAYS NO ERROR MESSAGE.**

### SUSPECT COMPONENTS

The following components are associated with this specific problem. One or more of these components may have failed partially or completely. If you cannot isolate the problem using this FIP, replace each component listed below, one at a time, until the problem disappears.

- **MCU PWB (RRP 9.123)**
- **Controller PWB (RRP 9.129)**
- **LVPS (RRP 9.119)**
- **ROS Assembly (RRP 9.47)**

Step	Actions and Questions	Yes	No
1	<b>PAPER INSPECTION</b> Inspect the paper that is loaded in the paper tray. <b>Is the paper wrinkled, dimpled, or show any signs of having a high moisture content?</b>	Load fresh, dry paper.	Go to step 2
2	<b>XEROGRAPHIC INSPECTION</b> 1. Generate a test print and slide the Fuser Assembly out of the printer just before the sheet of paper enters the Fuser. 2. Remove the Xerographic Cartridge (RRP 9.48). 3. Inspect the image on the Drum. <b>Is there a normal test print image, without any spot deletions, visible on the drum?</b>	Go to step 3	Go to step 7
3	<b>IBT INSPECTION</b> Inspect the image on the surface of the IBT? <b>Is there a normal test print image, without any spot deletions, visible on the surface of the IBT?</b>	Go to step 4	Replace the Transfer Assembly (RRP 9.71)
4	<b>2ND TRANSFER INSPECTION</b> 1. Generate a test print and slide the Fuser Assembly out of the printer just before the sheet of paper enters the Fuser. 2. Inspect the image on the sheet of paper just before the paper enter the Fuser. <b>Is there a normal test print image, without any spot deletions, visible on the sheet of paper?</b>	Go to step 5	Replace the 2ND BTR Assembly (RRP 9.75)

### 5.8 - Spot Deletions, continued

Step	Actions and Questions	Yes	No
5	<p><b>FUSER INSPECTION</b></p> <ol style="list-style-type: none"> <li>1. Generate a test print and slide the Fuser Assembly out of the printer just as the sheet of paper exits the Fuser.</li> <li>2. Inspect the image on the sheet of paper just after the paper exits the Fuser.</li> </ol> <p><b>Is there a normal test print image on the sheet of paper before entering the Fuser but the image has visible spot deletions after it exits the Fuser?</b></p>	Go to step 6	
6	<ol style="list-style-type: none"> <li>1. Replace the Oil Roll Assembly (RRP 9.82).</li> <li>2. Generate a test print.</li> <li>3. Inspect the image on the sheet.</li> </ol> <p><b>Is the image now normal, without spot deletions as it exits the Fuser?</b></p>	Problem Solved	Replace the Pressure Roll (RRP 9.83) and the Heat Roll (RRP 9.84)
7	<ol style="list-style-type: none"> <li>1. Replace the Xerographic Cartridge (RRP 9.48).</li> <li>2. Generate a test print.</li> </ol> <p><b>Is the image now normal, without spot deletions?</b></p>	Problem solved	Go to step 8
8	<p><b>DEVELOPER ASSEMBLY INSPECTION</b></p> <ol style="list-style-type: none"> <li>1. Remove the Top Cover (RRP 9.3).</li> <li>2. Turn the Rotary Frame and inspect the Magnet Roll of each of the four Developer Assemblies.</li> </ol> <p><b>Do the Magnet Rolls of each Developer Assembly appear smooth, evenly formed, without any low spots, and without obvious contamination?</b></p>	Go to Suspect Components	Replace the faulty Developer Assembly

## 5.9 - Spots

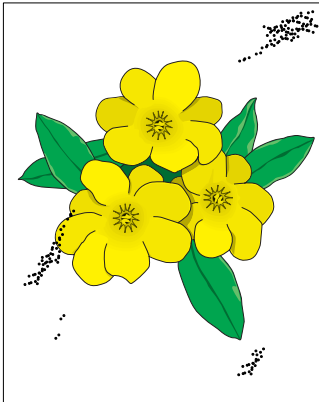

RS509X

### PROBLEM

There are spots of toner scattered randomly across the page. **THE PRINTER DISPLAYS NO ERROR MESSAGE.**

### SUSPECT COMPONENTS

The following components are associated with this specific problem. One or more of these components may have failed partially or completely. If you cannot isolate the problem using this FIP, replace each component listed below, one at a time, until the problem disappears.

- **MCU PWB (RRP 9.123)**
- **Waste Toner Sensor (RRP 9.53)**
- **Toner Cartridges (RRP 9.55, 9.56, 9.57, and 9.58)**
- **Developer Fan (RRP 9.122)**
- **2nd BTR Assembly (RRP 9.78)**

Step	Actions and Questions	Yes	No
1	<b>PAPER HANDLING ASSEMBLY INSPECTION</b> Slide the Main Paper Handling Assembly out of the printer and inspect the top of the Registration Chute Assembly. <b>Is the top of the Registration Chute Assembly free of toner?</b>	Go to step 2	Go to step 9
2	<b>XEROGRAPHIC CARTRIDGE INSPECTION</b> Remove the Xerographic Cartridge (RRP 9.48) and inspect the exterior of the Cartridge. <b>Is the exterior of the Xerographic Cartridge clean and with no obvious toner leakage?</b>	Go to step 3	Go to step 9
3	<b>DEVELOPER ASSEMBLY INSPECTION</b> 1. Remove the Top Cover (RRP 9.3). 2. Turn the Rotary Frame and inspect the four Developer Assemblies. <b>Does each Developer Assembly appear clean, with any obvious toner on the exterior of the Assembly or falling from the Magnet Brush</b>	Go to step 4	Clean the dirty Developer Assembly. If the problem reoccurs, replace the faulty Assembly
4	<b>FUSER INSPECTION</b> Slide the Fuser Assembly out of the printer and inspect the Assembly. <b>Is the Fuser Assembly free of toner?</b>	Go to step 5	Clean or replace the Fuser Assembly (RRP 9.80)
5	<b>BELT CLEANER INSPECTION</b> Remove the Belt Cleaner Assembly (RRP 9.76) and inspect the Assembly. <b>Is the Belt Cleaner Assembly clean and with no obvious toner leakage?</b>	Go to step 6	Replace the Belt Cleaner Assembly (RRP 9.76)

**5.9 - Spots, continued**

<b>Step</b>	<b>Actions and Questions</b>	<b>Yes</b>	<b>No</b>
<b>6</b>	<p><b>AUGER ASSEMBLY INSPECTION</b></p> <p>With the Belt Cleaner Assembly removed, inspect the Belt Cleaner end of the Auger.</p> <p><b>Is the Auger clogged?</b></p>	Go to step 7	Clean the printer interior
<b>7</b>	<p><b>AUGER DRIVE TEST</b></p> <ol style="list-style-type: none"> <li>1. Remove the Rear Cover (RRP 9.4).</li> <li>2. With the Belt Cleaner Assembly removed watch the Auger Drive Gear as you hand rotate the Paper Handling Motor.</li> </ol> <p><b>Does the Fuser Drive Assembly rotate the Auger Drive Gear?</b></p>	Go to step 8	Replace the Fuser Drive Assembly (RRP 9.110)
<b>8</b>	<p><b>AUGER SPRING TEST</b></p> <p>As you hand rotate the Paper Handling Motor place your finger inside the Auger opening and feel the movement of the Auger Spring.</p> <p><b>Does the Auger Spring rotate when you hand rotate the Paper Handling Motor?</b></p>	Go to step 9	Replace the Auger Assembly (RRP 9.77)
<b>9</b>	<p><b>WASTE TONER BOX GEAR INSPECTION</b></p> <p>Remove the Waste Toner Box (RRP 9.49) and inspect Box.</p> <p><b>Is the Waste Toner Box clean, not leaking toner, and not obviously damaged?</b></p>	Replace the Xerographic Cartridge (RRP 9.48)	Replace the Waste Toner Box (RRP 9.49)

## 5.10 - Residual Image or Ghosting

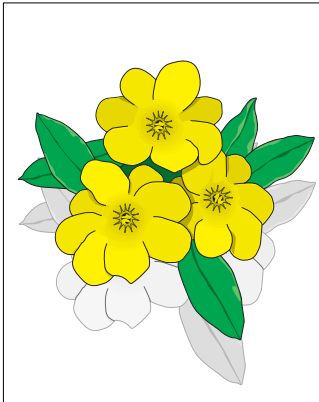

RS510X

### PROBLEM

There are faint ghostly images appearing randomly on the page. The images may be either from a previous page or from the page currently being printed. **THE PRINTER DISPLAYS NO ERROR MESSAGE.**

### SUSPECT COMPONENTS

The following components are associated with this specific problem. One or more of these components may have failed partially or completely. If you cannot isolate the problem using this FIP, replace each component listed below, one at a time, until the problem disappears.

- **MCU PWB (RRP 9.123)**
- **HVPS (RRP 9.120)**

Step	Actions and Questions	Yes	No
1	<b>CUSTOMER USAGE INSPECTION</b> Inspect the ghost images. <b>Was the customer printing numerous copies of the same image?</b>	Go to step 2	Go to step 3
2	Generate a print run of 20 to 30 pages of varying images.  <b>Do ghost images still appear?</b>	Go to step 3	Try to void printing numerous copies of the same image
3	<b>XEROGRAPHIC INSPECTION</b> 1. Generate a test print and slide the Fuser Assembly out of the printer just before the sheet of paper enters the Fuser. 2. Remove the Xerographic Cartridge (RRP 9.48). 3. Inspect the image on the Drum. <b>Is there a normal test print image, without ghosts, visible on the drum?</b>	Go to step 5	Go to step 4
4	<b>ERASE LAMP TEST</b> Use Diagnostics to test the Erase Lamp. <b>Does the Erase Lamp switch on when you run the Diagnostics Output Test?</b>	Replace the Xerographic Cartridge (RRP 9.48)	Replace the Erase Lamp (RRP 9.51)
5	<b>IBT INSPECTION</b> Inspect the image on the surface of the IBT? <b>Is there a normal test print image, without ghosts, visible on the surface of the IBT?</b>	Go to step 6	Replace the Belt Cleaner Assembly (RP 9.76)

**5.10 - Residual Image or Ghosting, continued**

Step	Actions and Questions	Yes	No
6	<p><b>FUSER INSPECTION</b></p> <ol style="list-style-type: none"> <li>1. Generate a test print and slide the Fuser Assembly out of the printer just as the sheet of paper exits the Fuser.</li> <li>2. Inspect the image on the sheet of paper just after the paper exits the Fuser.</li> </ol> <p><b>Is there a normal test print image on the sheet of paper before entering the Fuser but the image has ghost images after it exits the Fuser?</b></p>	Go to step 7	
7	<ol style="list-style-type: none"> <li>1. Replace the Oil Roll Assembly (RRP 9.82).</li> <li>2. Generate a test print.</li> <li>3. Inspect the image on the sheet.</li> </ol> <p><b>Is the image now normal, without ghost images, as it exits the Fuser?</b></p>	Problem Solved	Replace the Pressure Roll (RRP 9.83) and the Heat Roll (RRP 9.84)

## 5.11 - Background

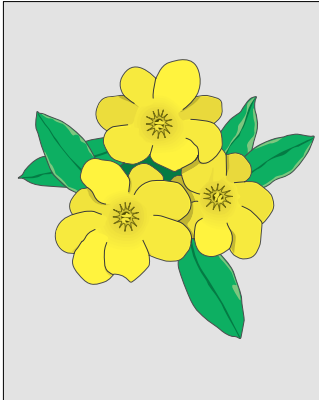

RS511X

### PROBLEM

There is toner contamination on all or most of the page. The contamination appears as a very light gray dusting. **THE PRINTER DISPLAYS NO ERROR MESSAGE.**

### SUSPECT COMPONENTS

The following components are associated with this specific problem. One or more of these components may have failed partially or completely. If you cannot isolate the problem using this FIP, replace each component listed below, one at a time, until the problem disappears.

- Developer Fan (RRP 9.122)
- ROS Assembly (RRP 9.47)
- Developer Assemblies (RRP 9.59, 9.61, 9.63, and 9.65)

Step	Actions and Questions	Yes	No
1	<p><b>XEROGRAPHIC INSPECTION</b></p> <ol style="list-style-type: none"> <li>1. Generate a test print and slide the Fuser Assembly out of the printer just before the sheet of paper enters the Fuser.</li> <li>2. Remove the Xerographic Cartridge (RRP 9.48).</li> <li>3. Inspect the image on the Drum.</li> </ol> <p><b>Is there a normal test print image, without background, visible on the drum?</b></p>	Go to step 3.	Go to step 2
2	<ol style="list-style-type: none"> <li>1. Replace the Xerographic Cartridge (RRP 9.48).</li> <li>2. Generate a test print and slide the Fuser Assembly out of the printer just before the sheet of paper enters the Fuser.</li> <li>3. Remove the Xerographic Cartridge (RRP 9.48).</li> <li>4. Inspect the image on the Drum.</li> </ol> <p><b>Is there a normal test print image, without background, visible on the drum?</b></p>	Problem solved	Replace the HVPS (RRP 9.120)
3	<p><b>IBT INSPECTION</b></p> <p>Inspect the image on the surface of the IBT?</p> <p><b>Is there a normal test print image, without background, visible on the surface of the IBT?</b></p>	Go to step 4	Go to step 5
4	<p>Replace the 2ND BTR Assembly (RRP 9.75).</p> <p><b>Is there a normal test print image, without background, visible on the surface of the IBT?</b></p>	Problem solved	Replace the HVPS (RRP 9.120)



**5.11 - Background, continued**

Step	Actions and Questions	Yes	No
5	<p><b>FUSER INSPECTION</b></p> <ol style="list-style-type: none"> <li>1. Generate a test print and slide the Fuser Assembly out of the printer just as the sheet of paper exits the Fuser.</li> <li>2. Inspect the image on the sheet of paper just after the paper exits the Fuser.</li> </ol> <p><b>Is there a normal test print image on the sheet of paper before entering the Fuser but the image has background after it exits the Fuser?</b></p>	Go to step 6	
6	<ol style="list-style-type: none"> <li>1. Replace the Oil Roll Assembly (RRP 9.82).</li> <li>2. Generate 20 test prints.</li> <li>3. Inspect the image on the last sheet.</li> </ol> <p><b>Is the image now normal, without background, as it exits the Fuser?</b></p>	Problem Solved	Replace the Pressure Roll (RRP 9.83) and the Heat Roll (RRP 9.84)

## 5.12 - Toner on Back of Print

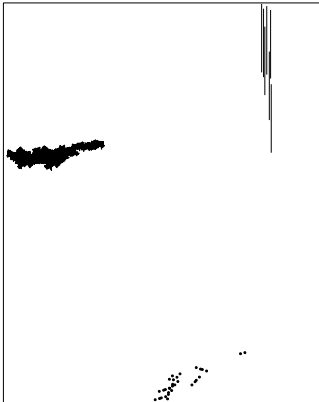

RS518X

### PROBLEM

There is toner contamination on the back of the fused sheet of paper. **THE PRINTER DISPLAYS NO ERROR MESSAGE.**

### SUSPECT COMPONENTS

The following components are associated with this specific problem. One or more of these components may have failed partially or completely. If you cannot isolate the problem using this FIP, replace each component listed below, one at a time, until the problem disappears.

- **Xerographic Cartridge (RRP 9.48)**
- **Waste Toner Box (RRP 9.49)**
- **Auger Assembly (RRP 9.77)**

Step	Actions and Questions	Yes	No
1	<p><b>PAPER STACK INSPECTION</b></p> <p>Inspect the paper that is loaded in the paper trays.</p> <p><b>Is the paper clean and free of toner?</b></p>	Go to step 2	Clean the Tray and replace the paper with fresh, clean paper
2	<p><b>MAIN PAPER HANDLING ASSEMBLY INSPECTION</b></p> <ol style="list-style-type: none"> <li>1. Generate a test print and slide the Fuser Assembly out of the printer just before the sheet of paper reaches the 2nd IBT.</li> <li>2. Slide the Main Paper Handling Assembly out of the printer and inspect the back of the sheet of paper.</li> </ol> <p><b>Is the back of the sheet of paper clean and free of toner?</b></p>	Go to step 3	Clean the Main Paper Handling Assembly and/or clean or replace the Metal Registration Roll (RRP 9.43) and the Rubber Registration Roll (RRP 9.44)
3	<p><b>2ND TRANSFER ASSEMBLY INSPECTION</b></p> <ol style="list-style-type: none"> <li>1. Generate a test print and slide the Fuser Assembly out of the printer just before the sheet of paper reaches the Fuser.</li> <li>2. Slide the Fuser Assembly out of the printer and inspect the back of the sheet of paper.</li> </ol> <p><b>Is the back of the sheet of paper clean and free of toner?</b></p>	Go to step 4	Replace the 2ND BTR Assembly (RRP 9.75) and if necessary also replace the Belt Cleaner Assembly (RRP 9.76)

**5.12 - Toner on Back of Print, continued**

Step	Actions and Questions	Yes	No
4	<p><b>FUSER INSPECTION</b></p> <ol style="list-style-type: none"> <li>1. Generate a test print and slide the Fuser Assembly out of the printer just as the sheet of paper exits the Fuser.</li> <li>2. Slide the Fuser Assembly out of the printer and inspect the back of the sheet of paper.</li> </ol> <p><b>Is the back of the sheet of paper clean and free of toner when it exits the Fuser?</b></p>	Go to step 5	Clean the Fuser Assembly and/or replace the Pressure Roll (RRP 9.83) and the Heat Roll (RRP 9.84)
5	<p><b>UPPER EXIT INSPECTION</b></p> <ol style="list-style-type: none"> <li>1. Generate a test print and open the Upper Exit Cover just as the sheet of paper reaches Exit Roll 3.</li> <li>2. Inspect the back of the sheet of paper.</li> </ol> <p><b>Is the back of the sheet of paper clean and free of toner as it nears Exit Roll 3?</b></p>	Clean the printer interior	Clean or replace the Upper Exit Assembly (RRP 9.102)

### 5.13 - Skewed Image

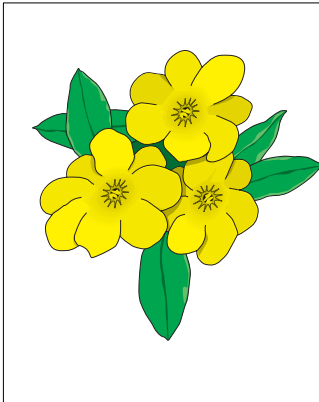

RS512X

#### PROBLEM

The image is twisted or is not parallel with the sides of the page. **THE PRINTER NEITHER JAMS NOR DISPLAYS AN ERROR MESSAGE.**

#### SUSPECT COMPONENTS

The following components are associated with this specific problem. One or more of these components may have failed partially or completely. If you cannot isolate the problem using this FIP, replace each component listed below, one at a time, until the problem disappears.

- **ROS Assembly (RRP 9.47)**
- **Controller PWB (RRP 9.129)**
- **MCU PWB (RRP 9.123)**
- **Xerographic Cartridge (RRP 9.48)**
- **Transfer Assembly (RRP 9.71)**
- **Main Paper Handling Assembly (RRP 9.36)**

Step	Actions and Questions	Yes	No
1	<p><b>FEEDER ISOLATION</b> Feed paper out of each of the available paper feeders</p> <p><b>Does the image skew when fed out of one tray but not when fed out of the other trays?</b></p>	Go to step 2	Go to step 4
2	<p><b>PAPER STACK INSPECTION</b> Inspect the paper that is loaded in the paper feeder that is skewing.</p> <p><b>Is the paper loaded correctly under the snubber and is the paper undamaged?</b></p>	Go to step 3	Reload the paper correctly or replace the paper if damaged
3	<p>Replace the MSI Pick Up Roll (RRP 9.29) or Tray 1 Feed Roll (RRP 9.14)</p> <p><b>Does the image still skew?</b></p>	Go to step 4	Problem solved
4	<p><b>MAIN PAPER HANDLING ASSEMBLY INSPECTION</b></p> <ol style="list-style-type: none"> <li>1. Generate a test print and slide the Fuser Assembly out of the printer just before the sheet of paper reaches the Registration Rolls.</li> <li>2. Carefully slide the Main Paper Handling Assembly out of the printer and inspect the position of the sheet of paper.</li> </ol> <p><b>Is the sheet of paper parallel to the edges of the Paper Handling Assembly?</b></p>	Go to step 5	Replace the Turn Roll Assembly (RRP 9.16)

## 5.13 - Skewed Image, continued

Step	Actions and Questions	Yes	No
5	<p><b>REGISTRATION ROLL INSPECTION</b></p> <ol style="list-style-type: none"> <li>1. Generate a test print and slide the Fuser Assembly out of the printer just as the sheet of paper is moving through the Registration Rolls.</li> <li>2. Carefully slide the Main Paper Handling Assembly out of the printer and inspect the position of the sheet of paper.</li> </ol> <p><b>Is the sheet of paper parallel to the edges of the Paper Handling Assembly as it leaves the Registration Rolls?</b></p>	Go to step 6	Replace the Metal Registration Roll (RRP 9.43) and the Rubber Registration Roll (RRP 9.44)
6	<p><b>2ND BTR INSPECTION</b></p> <ol style="list-style-type: none"> <li>1. Remove 2nd BTR Assembly (RRP 9.75)</li> <li>2. Manually raise and lower the cam levers at the ends of the 2nd BTR Assembly.</li> </ol> <p><b>Are the cam levers undamaged?</b>  <b>When you raise the levers does the 2nd BTR lower and when you release the levers does the 2nd BTR raise?</b>  <b>Do the cam levers have a strong spring action?</b></p>	Go to step 7	Replace the 2ND BTR Assembly (RRP 9.75)
7	<p><b>2ND BTR CAM ASSEMBLY INSPECTION</b></p> <p>With the 2nd BTR Assembly still removed, inspect the 2nd BTR Cam Assembly.</p> <p><b>Are the cams undamaged?</b></p>	Go to Suspect Components	Replace the 2ND BTR Ca Assembly (RRP 9.73)

## 5.14 - Damaged Prints

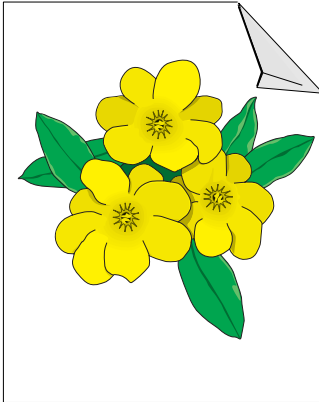

RS513X

### PROBLEM

The printed page exits the printer either wrinkled, creased, or torn. **THE PRINTER NEITHER JAMS NOR DISPLAYS AN ERROR MESSAGE.**

### SUSPECT COMPONENTS

The following components are associated with this specific problem. One or more of these components may have failed partially or completely. If you cannot isolate the problem using this FIP, replace each component listed below, one at a time, until the problem disappears.

- **Main Paper Handling Assembly (RRP 9.36)**
- **Transfer Assembly (RRP 9.71)**
- **Fuser Assembly (RRP 9.80)**

Step	Actions and Questions	Yes	No
1	<b>FEEDER ISOLATION</b> Feed paper out of each of the available paper feeders  <b>Is the paper damaged when fed out of one tray but not when fed out of the others?</b>	Go to step 2	Go to step 9
2	<b>Is the paper damaged when fed out of MSI?</b>	Go to step 5	Go to step 3
3	<b>Is the paper damaged when fed out of Tray 1?</b>	Go to step 7	Go to step 4
4	<b>Is the paper damaged when fed out of any tray in the HCF?</b>	Go to FIP 4.2 of the HCF Technical Manual	
5	<b>MSI PAPER INSPECTION</b> Inspect the paper that is loaded in the MSI.  <b>Is the paper in good condition and undamaged?</b>	Go to step 6	Replace the paper with new, undamaged paper
6	<b>MSI INSPECTION</b> 1. Remove the MSI Assembly (RRP 9.22). 2. Inspect the MSI Assembly for debris or obviously broken components that could be damaging the paper as it feeds out of the Assembly and into the printer.  <b>Is the MSI free of debris or broken components?</b>	Go to step 9	Clean the MSI, or replace the broken components or replace the MSI Assembly (RRP 9.22)
7	<b>TRAY 1 PAPER INSPECTION</b> Inspect the paper that is loaded in Tray 1.  <b>Is the paper in good condition and undamaged?</b>	Go to step 8	Replace the paper with new, undamaged paper

## 5.14 - Damaged Prints, continued

Step	Actions and Questions	Yes	No
8	<p><b>TRAY 1 INSPECTION</b></p> <p>Inspect Paper Tray 1 and Tray 1 Feeder Assembly for debris or obviously broken components that could be damaging the paper as it feeds out of the Tray and into the printer.</p> <p><b>Is Tray 1 and the Tray 1 Feeder free of debris or broken components</b></p>	Go to step 9	Clean Tray 1, or replace the broken components or replace the Tray
9	<p><b>REGISTRATION ROLL INSPECTION</b></p> <ol style="list-style-type: none"> <li>1. Generate a test print and slide the Fuser Assembly out of the printer just as the sheet of paper is moving through the Registration Rolls.</li> <li>2. Carefully slide the Main Paper Handling Assembly out of the printer and inspect the sheet of paper.</li> </ol> <p><b>Is the sheet of paper undamaged as it leaves the Registration Rolls?</b></p>	Go to step 10	Replace the Metal Registration Roll (RRP 9.43) and the Rubber Registration Roll (RRP 9.44)
10	<p><b>2ND TRANSFER ASSEMBLY INSPECTION</b></p> <ol style="list-style-type: none"> <li>1. Generate a test print and slide the Fuser Assembly out of the printer just before the sheet of paper reaches the Fuser.</li> <li>2. Slide the Fuser Assembly out of the printer and inspect the sheet of paper.</li> </ol> <p><b>Is the sheet of paper undamaged as it leaves the 2ND BTR?</b></p>	Go to step 11	Replace the 2ND BTR Assembly (RRP 9.75)
11	<p><b>FUSER INSPECTION</b></p> <ol style="list-style-type: none"> <li>1. Generate a test print and slide the Fuser Assembly out of the printer just as the sheet of paper exits the Fuser.</li> <li>2. Slide the Fuser Assembly out of the printer and inspect the sheet of paper.</li> </ol> <p><b>Is the sheet of paper undamaged as it exits the Fuser?</b></p>	Go to step 13	Go to step 12
12	<p><b>FUSER FINGER INSPECTION</b></p> <ol style="list-style-type: none"> <li>1. Slide the Fuser Assembly out of the printer.</li> <li>2. Inspect Main Fuser for debris, broken or dislodged components; such as the Fuser Fingers and the Upper Exit Guide.</li> </ol> <p><b>Is the Main Fuser free of debris and broken or dislodged components</b></p>	Go to step 13	Clean the Main Fuser or reseal or replace the faulty components

**5.14 - Damaged Prints, continued**

Step	Actions and Questions	Yes	No
13	<p><b>UPPER EXIT INSPECTION</b></p> <p>1. Generate a test print and open the Upper Exit Cover just as the sheet of paper reaches Exit Roll 3.</p> <p>2. Inspect the sheet of paper.</p> <p><b>Is the sheet of paper undamaged as it nears Exit Roll 3?</b></p>	Go to step 14	Clean or replace the Lower Exit Assembly (RRP 9.101) and the Upper Exit Assembly (RRP 9.102)
14	<p><b>EXIT ROLL 3 INSPECTION</b></p> <p><b>Is the sheet of paper undamaged until it reaches Exit Roll 3?</b></p>	Go to Suspect Components	Replace Exit 3 Roll Assembly (RRP 9.105)



### 5.15 - Unfused Image or Image Easily Rubs Off of Page

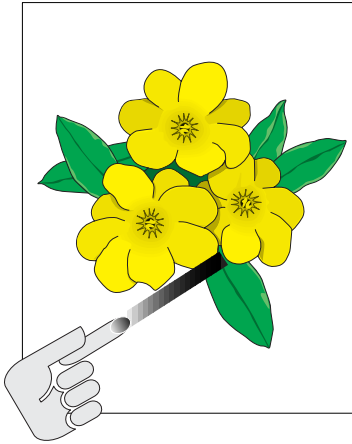

**PROBLEM**

The toner image is not completely fused to the paper. The image easily rubs off. **THE PRINTER DISPLAYS NO ERROR MESSAGE.**

**SUSPECT COMPONENTS**

The following components are associated with this specific problem. One or more of these components may have failed partially or completely. If you cannot isolate the problem using this FIP, replace each component listed below, one at a time, until the problem disappears.

- **Main Fuser Assembly (RRP 9.81)**

RS514X

Step	Actions and Questions	Yes	No
1	<b>IMAGE INSPECTION</b> Is the image density very light?	Go to FIP 5.1 Light (Under-toned) Prints	Go to step 2
2	Replace the Temperature Sensor Assembly (RRP 9.88) Is the image correctly fused?	Problem solved	Go to step 3
3	Replace the LVPS (RRP 9.119) Is the image correctly fused?	Problem solved	Go to step 4
4	Replace the MCU PWB (RRP 9.123) Is the image correctly fused?	Problem solved	Replace the Pressure Roll Heat Rod (RRP 9.85) and the Heat Roll Heat Rod (RRP 9.86)

### 5.16 - A Repetitive Mark Appears on Each Print

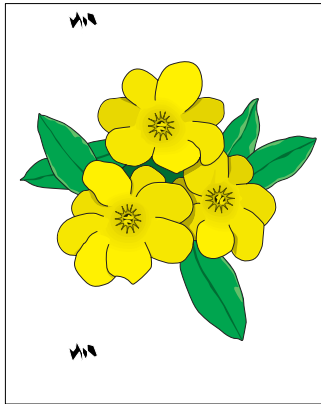

RS519X

#### PROBLEM

An identical mark or image defect appears on each, or every other, printed sheet. **THE PRINTER DISPLAYS NO ERROR MESSAGE.**

#### SUSPECT COMPONENTS

The following components are associated with this specific problem. One or more of these components may have failed partially or completely. If you cannot isolate the problem using this FIP, replace each component listed below, one at a time, until the problem disappears.

- **2ND BTR Assembly (RRP 9.75)**

Step	Actions and Questions	Yes	No
1	Replace the Xerographic Cartridge (RRP 9.48) <b>Does the mark still appear?</b>	Go to step 2	Problem solved
2	Replace the IBT Belt Assembly (RRP 9.78) <b>Does the mark still appear?</b>	Replace the Pressure Roll (RRP 9.83) and the Heat Roll (RRP 9.84)	Problem solved

### 5.17 - The Printed Image is Mottled

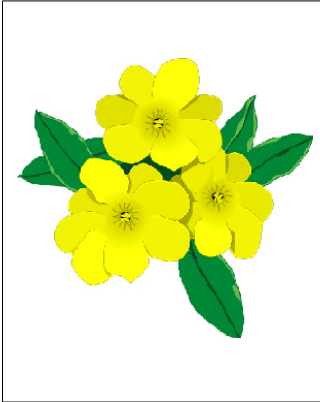

RS520X

**PROBLEM**

The printed image is either mottled or is textured like an orange peel. **THE PRINTER DISPLAYS NO ERROR MESSAGE.**

**SUSPECT COMPONENTS**

The following components are associated with this specific problem. One or more of these components may have failed partially or completely. If you cannot isolate the problem using this FIP, replace each component listed below, one at a time, until the problem disappears.

- Pressure Roll (RRP 9.83)
- Heat Roll (RRP 9.84)

Step	Actions and Questions	Yes	No
1	<p><b>SERVICE HISTORY INSPECTION</b></p> <p>Review recent service procedures done on the printer.</p> <p><b>Were there any recent service procedures done on the printer that involved removing the BTR Cam Solenoid or the 2nd BTR Cam Assembly?</b></p>	Go to RRP 9.74 and reposition the BTR Ca Solenoid according to instructions	Go to step 2
2	<p><b>2ND BTR AND 2ND BTR CAM INSPECTION</b></p> <p>1. Go to RRP 9.73 and remove the 2nd BTR Cam Assembly along with the 2nd BTR Assembly.</p> <p>2. Inspect the 2nd BTR Cam Assembly and the BTR Assembly for damage.</p> <p><b>Are the 2nd BTR Cam Assembly and the BTR Assembly damaged?</b></p>	Replace the damaged Assembly	Go to step 3
3	<p>Replace the Xerographic Cartridge (RRP 9.48)</p> <p><b>Is the image still mottled?</b></p>	Go to step 4	Problem solved
4	<p>Replace the 2nd BTR Assembly (RRP 9.75)</p> <p><b>Is the image still mottled?</b></p>	Go to step 5	Problem solved
5	<p>Replace the IBT Belt Assembly (RRP 9.78)</p> <p><b>Is the image still mottled?</b></p>	Go to Suspect Components	Problem solved

## 5.18 - Image Not Registered Correctly on the Page

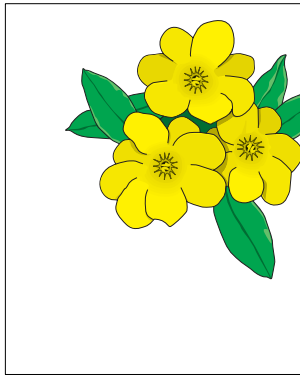

RS515X

### PROBLEM

The image area is not centered on the page or the image is bleeding off of the page. **THE PRINTER DISPLAYS NO ERROR MESSAGE.**

### SUSPECT COMPONENTS

The following components are associated with this specific problem. One or more of these components may have failed partially or completely. If you cannot isolate the problem using this FIP, replace each component listed below, one at a time, until the problem disappears.

- Registration Sensor (RRP 9.45)
- TR0 Sensor (RRP 9.79)
- Main Paper Handling Assembly (RRP 9.36)
- Controller PWB (RRP 9.129)
- Print Driver Software

Step	Actions and Questions	Yes	No
1	<b>PAPER INSPECTION</b> Inspect the paper that is loaded in the Paper Trays or MSI. <b>Is the paper loaded correctly and are the paper guides in place?</b>	Go to step 2	Reload paper correctly and position the paper guides
2	Replace the Metal Registration Roll (RRP 9.43) and the Rubber Registration Roll (RRP 9.44) <b>Is the image registered correctly on the page?</b>	Problem solved	Go to step 3
3	Replace the Registration Clutch (RRP 9.42) <b>Is the image registered correctly on the page?</b>	Problem solved	Go to step 4
4	Replace the MCU PWB (RRP 9.123) <b>Is the image registered correctly on the page?</b>	Problem solved	Replace the ROS Assembly (RRP 9.47)

### 5.19 - Color Layers are not Registered Correctly

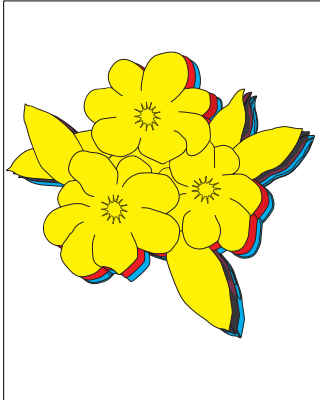

RS516X

**PROBLEM**

The four color images are not registered correctly and do not form a clean, four color image on the page. **THE PRINTER DISPLAYS NO ERROR MESSAGE.**

**SUSPECT COMPONENTS**

The following components are associated with this specific problem. One or more of these components may have failed partially or completely. If you cannot isolate the problem using this FIP, replace each component listed below, one at a time, until the problem disappears.

- Xerographic Cartridge (RRP 9.48)
- ROS Assembly (RRP 9.47)

Step	Actions and Questions	Yes	No
1	<b>SOFTWARE ISOLATION</b> Reload the printer driver software. <b>Is the four color image registered?</b>	Problem solved	Go to step 2
2	Replace the Controller PWB (RRP 9.129) <b>Is the four color image registered?</b>	Problem solved	Go to step 3
3	Replace the MCU PWB (RRP 9.123) <b>Is the four color image registered?</b>	Problem solved	Go to step 4
4	Replace the TR0 Sensor (RRP 9.79) <b>Is the four color image registered?</b>	Problem solved	Replace the Transfer Assembly (RRP 9.71)

## 5.20 - Color Representation Not Correct

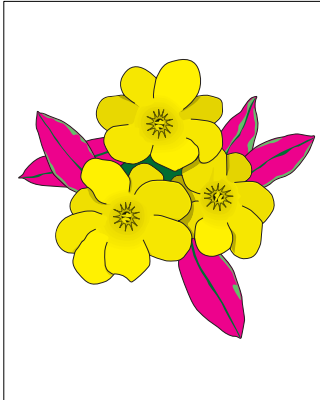

RS517X

### PROBLEM

The color of the printed image is completely different than the computer image. **THE PRINTER DISPLAYS NO ERROR MESSAGE.**

### SUSPECT COMPONENTS

The following components are associated with this specific problem. One or more of these components may have failed partially or completely. If you cannot isolate the problem using this FIP, replace each component listed below, one at a time, until the problem disappears.

- **No recommendations**

Step	Actions and Questions	Yes	No
1	<b>SOFTWARE ISOLATION</b> Reload the printer driver software. <b>Is the color correct?</b>	Problem solved	Go to step 2
2	Replace the Controller PWB (RRP 9.129) <b>Is the color correct?</b>	Problem solved	Go to step 3
3	Replace the MCU PWB (RRP 9.123) <b>Is the color correct?</b>	Problem solved	Go to step 4
4	Replace the Rotary Sensor (RRP 9.68) <b>Is the color correct?</b>	Problem solved	Go to step 5
5	<b>DEVELOPER ASSEMBLY INSPECTION</b> Inspect the four Toner Cartridges that are installed in the four Developer Assemblies.  <b>Are the correct color Toner Cartridges installed?</b>		Replace the Developer in the contaminated Developer Housing (RRP 9.60, 9.62, 9.64, and 9.66) and install the Toner Cartridges in the correct Developer Assembly

**Section 6 - Secondary FIPs**

**Contents**

---

6.1 Electrical Noise ..... 6-5

## 6 - Secondary FIPs

### Before entering the Secondary FIPs:

1. Is the printer plugged into a recommended AC wall outlet?
2. Is the AC power provided at the wall outlet within recommended specifications?
3. Is the AC power cord connected to the printer.
4. Is the AC power cord in good condition; not frayed or broken?
5. Is the printer properly grounded through the AC wall outlet?
6. Is the printer located in an area where the temperature and humidity are moderate and stable?
7. Is the printer located in an area that is free of dust?
8. Is the printer located in an area away from water outlets, steamers, electric heaters, volatile gases, or open flames?
9. Is the printer shielded from the direct rays of the sun?
10. Does the printer have recommended space around all sides for proper ventilation?
11. Is the printer on a level and stable surface?
12. Is recommended paper stock being used in the printer?
13. Does the customer use the printer as instructed in the User Manual?
14. Are consumables replaced at recommended intervals?
15. Do you have access to QMS Engine Diagnostic menus and do you know how to use them?
16. Are all of the printer assemblies in place and are all of printer covers and doors firmly closed?



## 6.1 - Electrical Noise

Step	Actions and Questions	Yes	No
	<p><b>SUSPECT COMPONENTS</b> The following components are associated with this specific problem. One or more of these components may have failed partially or completely. If you cannot isolate the problem using this FIP, replace each component listed below, one at a time, until the problem disappears.</p> <ul style="list-style-type: none"> <li>• Motors and Motor PWBs</li> <li>• Solenoids</li> <li>• ROS Assembly (RRP 9.47)</li> <li>• 2ND BTR Assembly (RRP 9.75)</li> </ul>		
<b>1</b>	<p><b>EXTERNAL NOISE</b> 1. Check if there is other electrical equipment, such as electrical generators, radio transmitters, or devices using electrical motors, within ten feet of the printer. 2. Shut off the other electrical equipment or relocate the printer to at least twenty feet away from the other devices.</p> <p><b>Is the Electrical Noise problem still present?</b></p>	Go to step 2	Permanently relocate either the printer or the problem device.
<b>2</b>	<p><b>OPTION ISOLATION</b> If the printer has the optional Large Capacity Input Feeder installed, remove the Feeder and see how the printer operations without it installed.</p> <p><b>Does the Electrical Noise problem go away when you remove a specific option?</b></p>	Go to step 3	Go the LCIF Technical Manual and troubleshoot for arcing solenoids, motor, faulty PWBs or faulty wiring.
<b>3</b>	<p><b>AC GROUND</b> Check the AC wall outlet.</p> <p><b>Is the AC wall outlet correctly wired and grounded?</b></p>	Go to step 4	Customer to arrange for repair of AC wall outlet
	<p><b>Steps 4 through 9 attempt to find a faulty printer component that may be generating electrical noise. If replacing a component does not solve the problem, reinstall the old component before moving on to the next step.</b></p>		
<b>4</b>	<p>Replace the OPC Drum (RRP 9.48)</p> <p><b>Is the Electrical Noise problem still present?</b></p>	Go to step 5	Problem solved
<b>5</b>	<p>Replace the LVPS (RRP 9.119)</p> <p><b>Is the Electrical Noise problem still present?</b></p>	Go to step 6	Problem solved
<b>6</b>	<p>Replace the HVPS Assembly (RRP 9.120)</p> <p><b>Is the Electrical Noise problem still present?</b></p>	Go to step 7	Problem solved

**6.1 - Electrical Noise, continued**

---

<b>Step</b>	<b>Actions and Questions</b>	<b>Yes</b>	<b>No</b>
<b>7</b>	Replace the MCU PWB (RRP 9.123) <b>Is the Electrical Noise problem still present?</b>	Go to step 8	Problem solved.
<b>8</b>	Replace the Controller PWB (RRP 9.129) <b>Is the Electrical Noise problem still present?</b>	Go to step 9	Problem solved.
<b>9</b>	Replace the Fuser Assembly (RRP 9.80) <b>Is the Electrical Noise problem still present?</b>	Go to suspect components	Problem solved.

**Section 7 - Getting Connected to Engine Diagnostics** **Contents**

---

Connecting to Engine Diagnostics ..... 7-2  
Portable Computer to Printer Setup Procedure ..... 7-2  
Terminal Program Setup ..... 7-2  
    HyperTerminal Setup Procedure ..... 7-2  
    VTERM Setup Procedure ..... 7-3

## Connecting to Engine Diagnostics

This section explains how to access the two diagnostic areas of Engine Diagnostics. The two areas are:

1. Printing / Status Control
2. Diagnostics Control

The performance of Fault Isolation within the Engine Diagnostics is covered in Section 9.

## Required Equipment

The following equipment is required to connect to the Engine Diagnostics:

1. Portable Computer
2. Debug Cable (available from QMS, Inc.)
3. RS232 PC Cable (local purchase)
4. Terminal Program (i.e., HyperTerminal, VTERM, etc.)
5. #2 Phillips Head Screwdriver

## Portable Computer to Printer Setup Procedure

1. Remove Printer MCU PWB Cover, right side of Printer (might require the use of #2 Phillips head screwdriver)
2. Connect Serial Cable to Portable Computer's Serial Port (refer to computer's user guide)
3. Connect Debug Cable to Serial Cable
4. Connect Debug Cable to Debug Port on MCU PWB

## Terminal Program Setup

### HyperTerminal (Windows 95 O/S)

1. Bootup Portable Computer to Windows 95, once booted up and running, start the HyperTerminal program
2. Create a "New Connection"
  - a. Type in Name and choose Icon
  - b. Select the Com Port that your serial port is connected to, either "Direct to Com 1", "Direct to Com 2", "Direct to Com 3", or "Direct to Com 4".
  - c. Make the following selections for the Com Properties:
    - Bits per second; select "9600"
    - Data bits; select "8"
    - Parity; select "None"
    - Stop bits; select "1"
    - Flow Control; select "Xon/Xoff"
  - Select "OK" button

Once the new connection setup procedure is completed, HyperTerminal will automatically connect to the serial cable through the Com port you selected. You are now ready to run the Engine Diagnostics (refer to section 9).

### **VTERM (DOS O/S)**

1. Bootup Portable Computer to DOS
2. At the C:\ prompt, type "VTERM"
3. Once VTERM has started, enter the setup menu, select "F5"
4. Make the following the selections in the setup menus:

Terminal type; select "VT100 (ANSI)"

New line; select "OFF"

Wrap around; select "ON"

Scroll; select "NORMAL"

Screen; select "NORMAL VIDEO"

Cursor type; select "UNDERLINE"

Margin bell; select "OFF"

DA response; select "NO OPTIONS"

Status line; select "ON"

Backspace sends; select "DELETE"

Shift - 3 displays; select "#"

Screen format; select "80 x 24"

1 3 2 column method; select "SCROLLING"

Window movement; select "DELAYED FOLLOW"

Scrollback buffer; select "ALLOW OVERFLOW"

Communications rate; select "9600"

Data bits/parity; select "8 NONE"

Receive parity; select "IGNORE"

Stop bits; select "ONE"

Auto Xon/Xoff; select "ON"

Local echo; select "OFF"

On line/local; select "ON LINE"

Printer output to; User select

After PrtSc; User select

## Getting Connected to Engine Diagnostics

Extent; select "ENTIRE SCREEN"

Wide; select "OFF"

Select "F5" to continue on to the next menu

Protocol; select "ASCII TEXT"

Maximum send rate; select "AT BAUD RATE"

How many secs/10; select "1"

End of line; select "CR-LF"

Convert null lines to a space; select "NO"

Remove escape sequences; select "NO"

Stop upon receiving; leave blank

The setup procedure is now completed, select "Esc" to end setup.

5. Power "ON" the printer (wait for the printer to finish it's power up sequence before proceeding)  
VTERM will automatically connect to the serial cable through the Com port.
  6. Press the "Ctrl" & "D" keys simultaneously to reach the "<DBG> prompt
  7. Type "edg" for the Main Menu to appear
- You are now ready to run the Engine Diagnostics (refer to section 9).

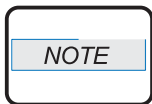

*If a test result becomes suspect during the Engine Diagnostic testing, the printer should be turned "OFF", and then steps 5 through 7 should be repeated. After the printer has powered back up, repeat the suspect test to confirm the results of the initial test.*

## **Section 8 - Accessing Life Counters From Engine EEPROM Contents**

Life Counters Overview .....	8-2
Retrieving Life Counters Data .....	8-2

## Life Counters Overview

This section of the Technical Manual is to instruct you on how to access the Life Counters found in the Engine EEPROM. The data contained in the Life Counters can be very a useful troubleshooting tool. Typically, when the printer display (LCD) shows an error message, the technician will take the appropriate action to correct the discrepancy. However, if the technician suspects an erroneous error message, the technician should collect the current data from the Life Counters, run the printer through several print cycles, then check the Life Counters again to make sure that the MCU PWB is correctly collecting the data. The improper collection of data would indicate a bad MCU PWB. The following Life Counters are included in the Engine EEPROM:

1. OPC/Xerographic Cartridge
2. Yellow Toner Accumulative Dispense Time
3. MegentaToner Accumulative Dispense Time
4. Cyan Toner Accumulative Dispense Time
5. Black Toner Accumulative Dispense Time
6. Fuser Unit Accumulative Run Time
7. Fuser Unit Accumulative Images Processed
8. 2nd Bias Transfer Roller Assembly
9. Belt Cleaner Assembly
10. Base Engine Accumulative Prints Processed
11. Base Engine Accumulative Images Processed

## Retrieving the Life Counters Data

1. Access to the Life Counters is gained through the Engine Diagnostics, refer to Chapter 8.
2. In the Engine Diagnostics Menu; select "2" for the "Diagnostics Control"
3. In the Diagnostics Control Commands Menu; select "b" for the "90,07 Read Engine EEPROM"



## Section 9 - Removal and Replacement Procedures Contents

---

Preparation .....	9-5
Work Notes .....	9-5
Notations in the RRP Text .....	9-5
RRP 9.1 Front Cover Assembly .....	9-6
RRP 9.2 Inner Cover Assembly .....	9-8
RRP 9.3 Top Cover Assembly .....	9-10
RRP 9.4 Rear Cover .....	9-12
RRP 9.5 Front Lower Cover .....	9-14
RRP 9.6 Filter Assembly .....	9-16
RRP 9.7 Left Lower Cover .....	9-18
RRP 9.8 Right Cover Assembly .....	9-20
RRP 9.9 Operation Panel .....	9-22
RRP 9.10 Front Snubber .....	9-24
RRP 9.11 End Guide .....	9-26
RRP 9.12 Sector Gear .....	9-28
RRP 9.13 Feed Roll Assembly .....	9-30
RRP 9.14 Feed Roll .....	9-32
RRP 9.15 Feed Solenoid .....	9-34
RRP 9.16 Turn Roll Assembly .....	9-36
RRP 9.17 Size Switch Assembly .....	9-38
RRP 9.18 No Paper Sensor Assembly .....	9-40
RRP 9.19 Low Paper Sensor .....	9-42
RRP 9.20 Turn IN Chute .....	9-44
RRP 9.21 Universal Paper Tray .....	9-46
RRP 9.22 MSI Assembly .....	9-48
RRP 9.23 MSI Front Cover .....	9-50
RRP 9.24 MSI Rear Cover .....	9-52
RRP 9.25 MSI Tray Assembly .....	9-54
RRP 9.26 MSI Top Cover Assembly .....	9-56
RRP 9.27 MSI Edge Sensor .....	9-58
RRP 9.28 MSI Short No Paper Sensor .....	9-60
RRP 9.29 MSI Pick Up Roll .....	9-62
RRP 9.30 MSI Roll Assembly .....	9-64
RRP 9.31 MSI Pick Up Solenoid .....	9-66
RRP 9.32 MSI Clutch .....	9-68
RRP 9.33 MSI Retard Pad Assembly .....	9-70
RRP 9.34 MSI Bottom Assembly .....	9-72
RRP 9.35 MSI Long No Paper Sensor .....	9-74
RRP 9.36 Main Paper Handling Assembly .....	9-76
RRP 9.37 Paper Handling Turn Chute Assembly .....	9-78
RRP 9.38 Pre-Registration Chute Assembly .....	9-80
RRP 9.39 Registration Chute Assembly .....	9-82
RRP 9.40 Pre-Registration Roll Assembly .....	9-84
RRP 9.41 Pre-Registration Clutch .....	9-86
RRP 9.42 Registration Clutch .....	9-88

## Section 9 - Removal and Replacement Procedures Contents

---

RRP 9.43 Metal Registration Roll . . . . .	9-90
RRP 9.44 Rubber Registration Roll . . . . .	9-92
RRP 9.45 Registration Sensor . . . . .	9-94
RRP 9.46 Registration Brake Clutch. . . . .	9-96
RRP 9.47 ROS Assembly. . . . .	9-98
RRP 9.48 Xerographic Cartridge . . . . .	9-100
RRP 9.49 Waste Toner Box . . . . .	9-102
RRP 9.50 ADC Sensor Assembly . . . . .	9-104
RRP 9.51 Erase Lamp Assembly . . . . .	9-106
RRP 9.52 XL Rail Assembly . . . . .	9-108
RRP 9.53 Waste Toner Sensor. . . . .	9-110
RRP 9.54 Toner Box Sensor. . . . .	9-112
RRP 9.55 Yellow (Y)Toner Cartridge. . . . .	9-114
RRP 9.56 Magenta (M) Toner Cartridge . . . . .	9-116
RRP 9.57 Cyan (C) Toner Cartridge . . . . .	9-118
RRP 9.58 Black (K) Toner Cartridge . . . . .	9-120
RRP 9.59 Yellow (Y) Developer Assembly . . . . .	9-122
RRP 9.60 Yellow (Y) Developer . . . . .	9-124
RRP 9.61 Magenta (M) Developer Assembly. . . . .	9-126
RRP 9.62 Magenta (M) Developer . . . . .	9-128
RRP 9.63 Cyan (C) Developer Assembly. . . . .	9-130
RRP 9.64 Cyan (C) Developer . . . . .	9-132
RRP 9.65 Black (K) Developer Assembly. . . . .	9-134
RRP 9.66 Black (K) Developer . . . . .	9-136
RRP 9.67 Rotary Frame Assembly . . . . .	9-138
RRP 9.68 Rotary Sensor. . . . .	9-140
RRP 9.69 Cartridge Sensor . . . . .	9-142
RRP 9.70 Used Cartridge Sensor. . . . .	9-144
RRP 9.71 Transfer Assembly . . . . .	9-146
RRP 9.72 Tension Lever . . . . .	9-148
RRP 9.73 2nd BTR Cam Assembly . . . . .	9-150
RRP 9.74 BTR Cam Solenoid. . . . .	9-152
RRP 9.75 2nd BTR Assembly. . . . .	9-154
RRP 9.76 Belt Cleaner Assembly . . . . .	9-156
RRP 9.77 Auger Assembly . . . . .	9-158
RRP 9.78 IBT Belt Assembly . . . . .	9-160
RRP 9.79 TR0 Sensor . . . . .	9-162
RRP 9.80 Fuser Assembly . . . . .	9-164
RRP 9.81 Main Fuser Assembly. . . . .	9-166
RRP 9.82 Oil Roll Assembly . . . . .	9-168
RRP 9.83 Pressure Roll . . . . .	9-170
RRP 9.84 Heat Roll. . . . .	9-172
RRP 9.85 Pressure Roll Heat Rod . . . . .	9-174
RRP 9.86 Heat Roll Heat Rod. . . . .	9-176
RRP 9.87 Upper Fuser Assembly . . . . .	9-178

## **Section 9 - Removal and Replacement Procedures** **Contents**

---

RRP 9.88 Temperature Sensor Assembly .....	9-180
RRP 9.89 Fuser Exit Sensor .....	9-182
RRP 9.90 Exit-1 Roll Assembly .....	9-184
RRP 9.91 Exchange Chute .....	9-186
RRP 9.92 Exchange Solenoid .....	9-188
RRP 9.93 Oil Cam Solenoid .....	9-190
RRP 9.94 Oil Cam Assembly .....	9-192
RRP 9.95 CRU Switch Assembly .....	9-194
RRP 9.96 Cleaner Cam Solenoid .....	9-196
RRP 9.97 Cleaner Cam Assembly .....	9-198
RRP 9.98 Upper Guide Assembly .....	9-200
RRP 9.99 Lower Guide Assembly .....	9-202
RRP 9.100 Exit Tray .....	9-204
RRP 9.101 Lower Exit Assembly .....	9-206
RRP 9.102 Upper Exit Assembly .....	9-208
RRP 9.103 Full Stack Sensor .....	9-210
RRP 9.104 Exit-2 Roll Assembly .....	9-212
RRP 9.105 Exit-3 Roll Assembly .....	9-214
RRP 9.106 Top Exit Sensor .....	9-216
RRP 9.107 Exit Chute Switch .....	9-218
RRP 9.108 Fuser Fan .....	9-220
RRP 9.109 Paper Handling Drive Assembly .....	9-222
RRP 9.110 Fuser Drive Assembly .....	9-224
RRP 9.111 Paper Handling Motor Assembly .....	9-226
RRP 9.112 Process Motor Assembly .....	9-228
RRP 9.113 Process Drive Assembly .....	9-230
RRP 9.114 Rotary Motor Assembly .....	9-232
RRP 9.115 Rotary Motor PWB .....	9-234
RRP 9.116 Dispense Motor Assembly .....	9-236
RRP 9.117 Developer Clutch Assembly .....	9-238
RRP 9.118 Developer Tie Plate .....	9-240
RRP 9.119 Low Voltage Power Supply (LVPS) .....	9-242
RRP 9.120 High Voltage Power Supply (HVPS) .....	9-244
RRP 9.121 Top Cover Switch .....	9-246
RRP 9.122 Developer Fan .....	9-248
RRP 9.123 MCU PWB .....	9-250
RRP 9.124 Front Cover Switch R .....	9-252
RRP 9.125 Front Cover Switch L .....	9-254
RRP 9.126 Environment Sensor .....	9-256
RRP 9.127 Controller Chassis Assembly .....	9-258
RRP 9.128 Controller Fan .....	9-260
RRP 9.129 Controller PWB .....	9-262
RRP 9.130 Fuser Entrance Sensor .....	9-264
RRP 9.131 Fuser Chute Fan .....	9-266

Blank Page

## Removal and Replacement Procedures (RRPs)

This section contains the removal and replacement procedures for major parts within the printer.

### Preparation

Before you begin any Removal and Replacement Procedure:

1. Switch OFF the printer power.
2. Disconnect the AC power cord from the wall outlet.
3. Remove the Xerographic Cartridge and cover it with a dark cloth or place it in a sealed container to protect it from exposure to light.
4. Disconnect all interface cables from the back of the printer.
5. Wear an electrostatic discharge wrist strap to protect sensitive printer PWBs from damage.
6. Wait at least 45 minutes for the Fuser to cool before removing parts in the Fuser area.

### Work Notes

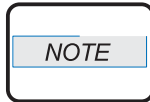

*Names of parts that appear in the RRP's may not be exactly the same as the names appear in the Parts List. For example, a part called the Metal Registration Roll in an RRP may appear on the Parts List as Registration Metal Roll.*

*When working on an RRP ignore any noted prerequisite steps if you have already performed them.*



*Always reinstall the correct type and size screws. Using the wrong screw can damage tapped holes. Do not use excessive force to either remove or install a part.*

### Notations in the RRP text

- Locations, such as R or right, given in the RRP's assume you are facing the printer console panel.
- The notation "rear" of a component, in place or removed, refers to the side of the component that is, when installed, facing the rear of the print engine.

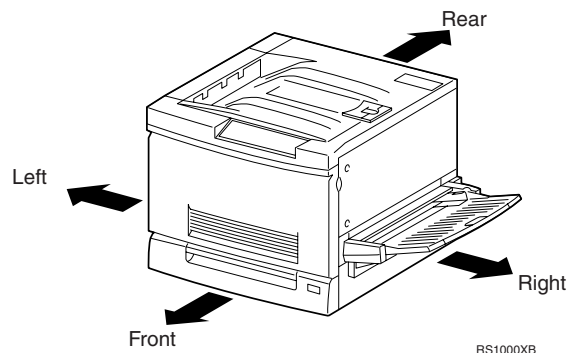

RS1000XB

- The notation "front" of a component refers to the side of the component that is, if installed, facing the front of the print engine.
- The notation "(RRP X.Y)" in a RRP step, directs you to another RRP for information on how to perform a related or pre-requisite procedure.
- The notation "(Figure x)" points to the illustration that corresponds to the RRP you are performing.
- The notation "(PLX)" indicates that this component is listed in the PLX parts list.
- Arrows in an illustration show direction of movement when removing a component.

## RRP 9.1 Front Cover Assembly (PL1.1.1)

---

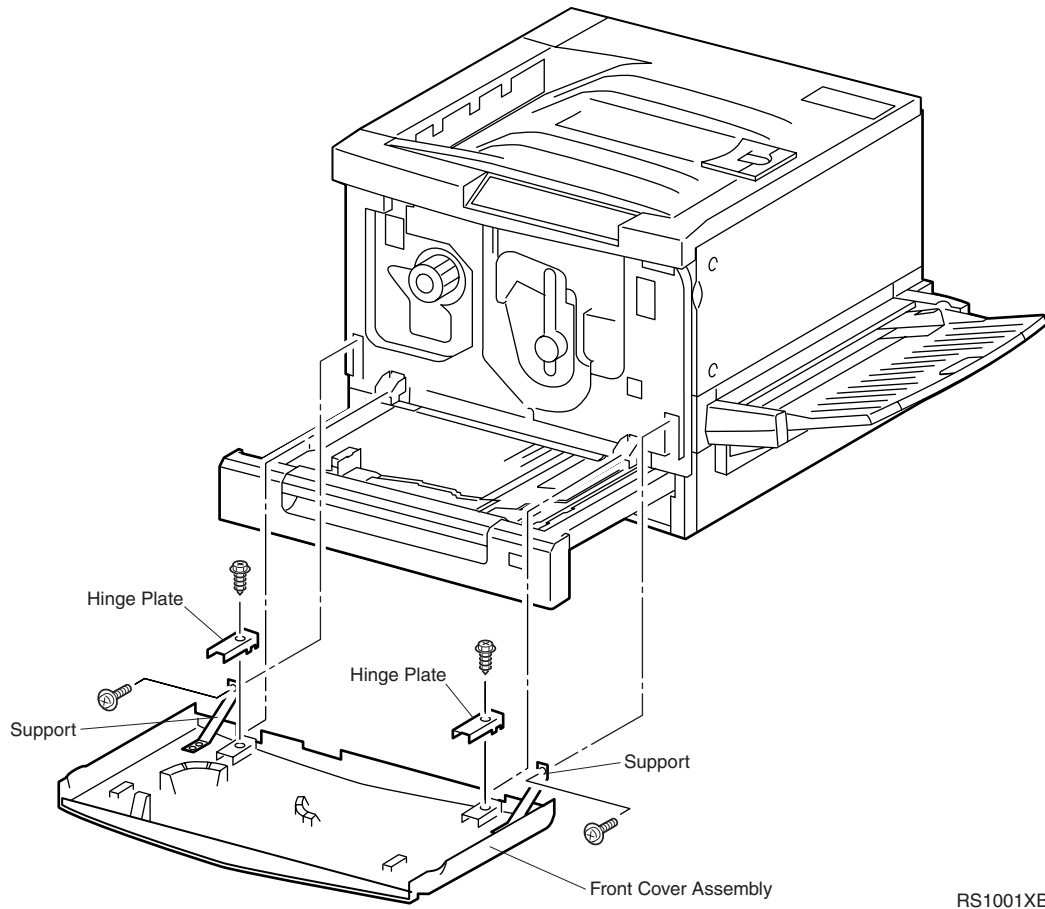

RS1001XB

RS1001XB

## **RRP 9.1 Front Cover Assembly (PL1.1.1)**

---

### **Removal**

1. Slide Tray 1 halfway out of the printer.
2. Open the Front Cover and let it rest on top of Tray 1.
3. Remove the two screws securing the two Hinge Plates to the Front Cover and remove the Plates.
4. Two the two screws securing the two Front Cover Supports to the printer frame.
5. Remove the Front Cover Assembly from the printer.

### **Replacement**

1. Slide Tray 1 halfway out of the printer.
2. Position the Front Cover Assembly as shown in the figure, making sure the Cover lip is under the two metal hinges that are protruding from the printer.
3. Let the Front Cover Assembly rest on top of Tray 1.
4. Reinstall each of the two Hinge Plates so one end of each Plate is over the metal hinges.
5. Align each Plate with the positioning tabs and screw holes on the Front Cover Assembly.
6. Use two screws to secure the two Hinge Plates to the Front Cover Assembly, but tighten the screws only halfway.
7. Reposition the Cover and the Plates, so the notches at the end of each Plate fit over each of the metal hinges.
8. Tighten the two screws to secure the Hinge Plates to the Front Cover.
9. Reattach the two Front Cover Supports to the frame and use two screws to secure the Supports.
10. Close and open the Front Cover Assembly, making sure the Cover moves freely and without binding.
11. Slide Tray 1 back into the printer.

## RRP 9.2 Inner Cover Assembly (PL1.1.10)

---

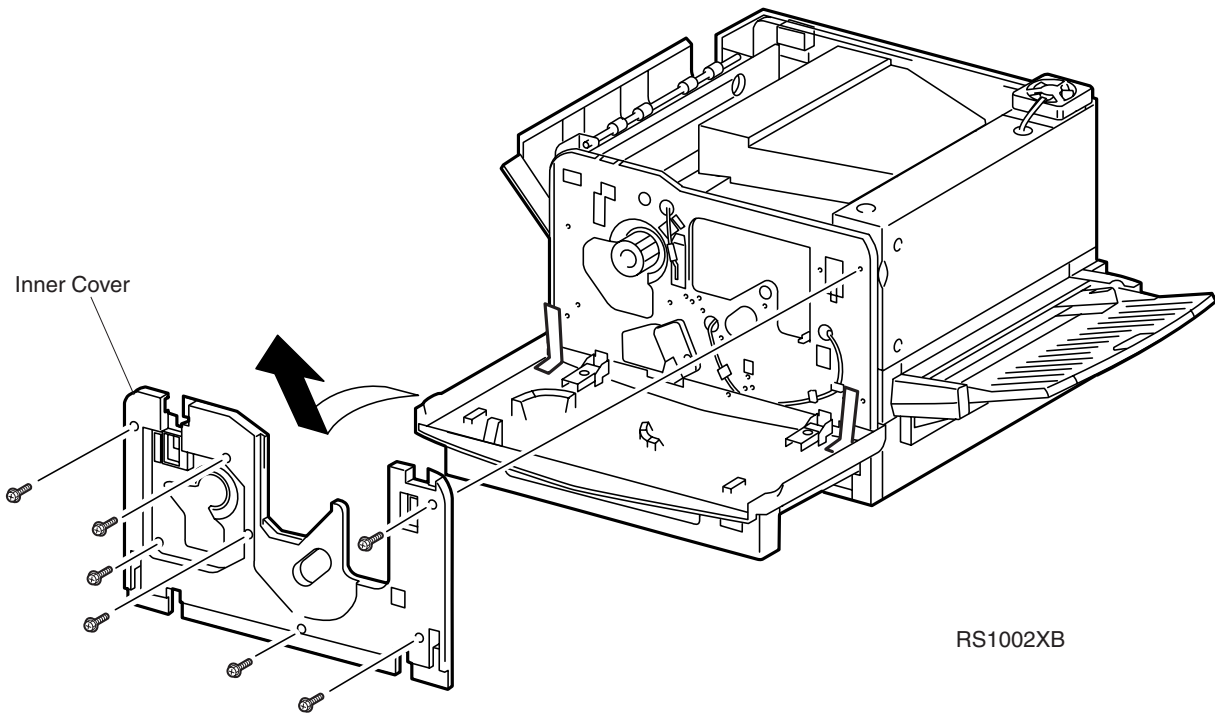

RS1002XB



## **RRP 9.2 Inner Cover Assembly (PL1.1.10)**

---

### **Removal**

1. Remove the Front Cover Assembly (RRP 9.1).
2. Remove the Xerographic Cartridge (RRP 9.48).
3. Remove the Tension Lever (RRP 9.72).
4. Remove the seven screws securing the Inner Cover to the printer frame and remove the Cover.

### **Replacement**

1. Position the Inner Cover against the printer frame, making sure the top of the Cover is under the lip of the Top Cover.
2. Use seven screws to secure the Inner Cover to the printer frame.
3. Reinstall the Tension Lever (RRP 9.72).
4. Reinstall the Xerographic Cartridge (RRP 9.48).
5. Reinstall the Front Cover Assembly (RRP 9.1).

## RRP 9.3 Top Cover Assembly (PL1.1.20)

---

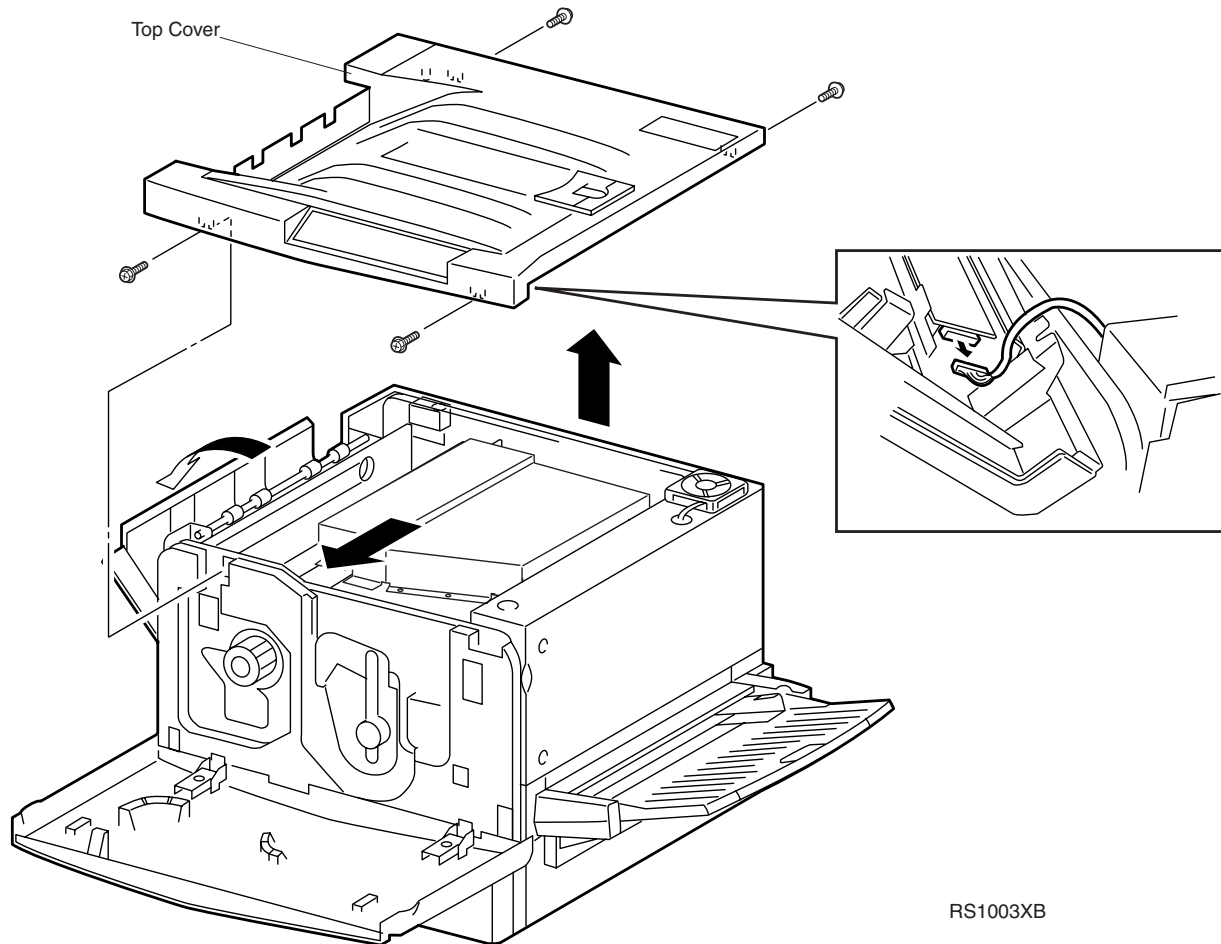

RS1003XB

## **RRP 9.3 Top Cover Assembly (PL1.1.20)**

---

### **Removal**

1. Remove the Rear Cover (RRP 9.4).
2. Open the Front Cover.
3. Remove the two screws securing the Top Cover to the front of the printer frame.
4. Open the Upper Exit Cover.
5. Lift the rear of the Top Cover off of the rear of the printer frame.
6. Reach under the Top Cover and disconnect P/J317 from the Operation Panel.
7. Slide the Top Cover to the front of the printer and lift the front of the Cover off of the printer frame.

### **Replacement**

1. Remove the Rear Cover (RRP 9.4).
2. Open the Front Cover.
3. Open the Upper Exit Cover.
4. Position the Top Cover as shown in the figure.
5. Push the Full Stack Sensor actuator out of the way.
6. Slide the front of the Top Cover onto the front of the printer frame.
7. Reconnect P/J317 to the Operation Panel.
8. Reinstall the rear of the Top Cover onto the rear of the printer frame.
9. Reposition the Top Cover so the Exit Rolls fit through the cutouts in the left side of the Top Cover.
10. Reposition the Top Cover so the two screw holes at the rear of the Cover and the two holes at the front of the Cover line up with the screw holes in the printer frame.
11. Use two screws to secure the front of the Top Cover to the printer frame.
12. Close the Upper Exit Cover.
13. Close the Front Cover.
14. Reinstall the Rear Cover (RRP 9.4).

## RRP 9.4 Rear Cover (PL1.1.31)

---

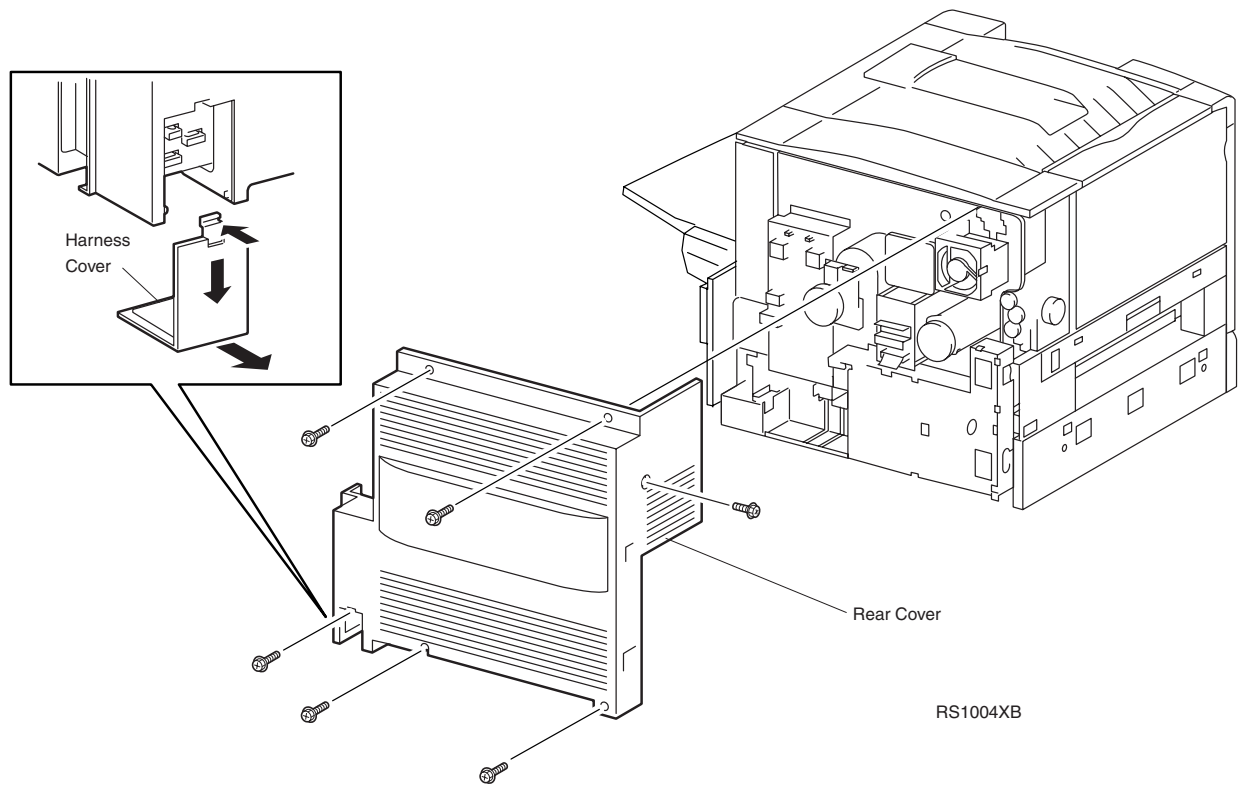

RS1004XB

## **RRP 9.4 Rear Cover (PL1.1.31)**

---

### **Removal**

1. Open the Upper Exit Cover.
2. Remove the Harness Cover.
3. Slide the Main Paper Handling Assembly a few inches out of the printer.
4. Remove the six screws securing the Rear Cover to the printer frame and remove the Cover.

### **Replacement**

1. Open the Upper Exit Cover.
2. Slide the Main Paper Handling Assembly a few inches out of the printer.
3. Reinstall the Rear Cover onto the printer frame.
4. Reposition the Cover so the six screw holes in the Cover line up with the five screw holes in the printer frame.
5. Use five screws to secure the Rear Cover to the printer frame.
6. Slide the Main Paper Handling Assembly into the printer.
7. Reinstall the Harness Cover.
8. Close the Upper Exit Cover.

## RRP 9.5 Front Lower Cover (PL1.1.5)

---

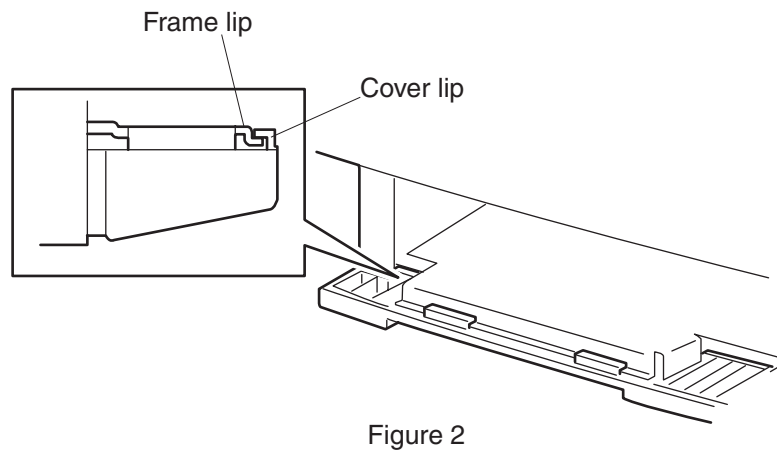
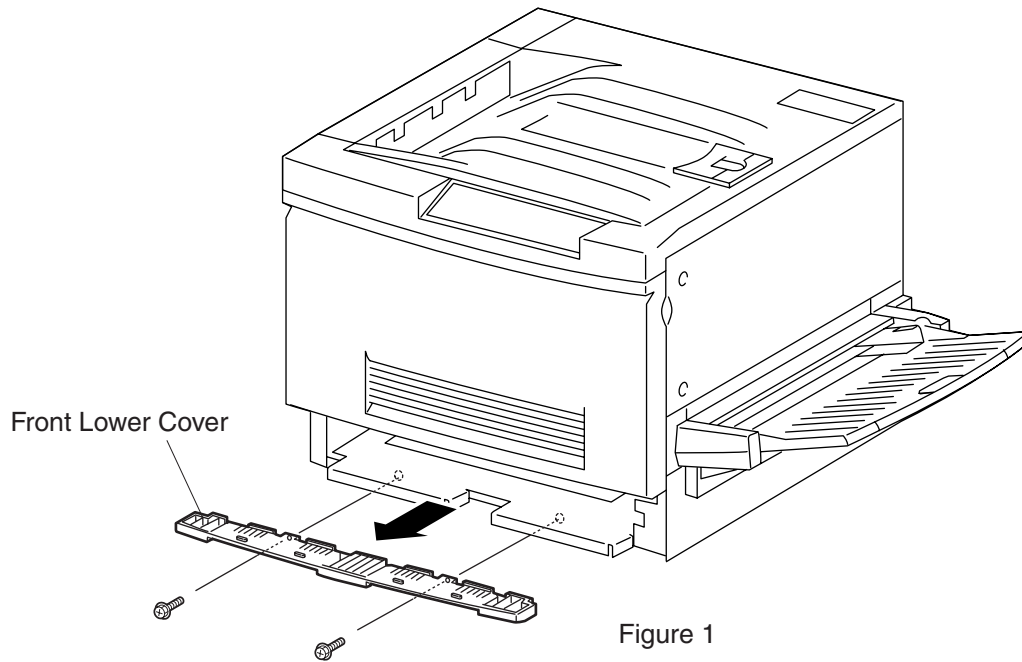

RS1051XB

RS1051XB

## **RRP 9.5 Front Lower Cover (PL1.1.5)**

---

### **Removal**

1. Remove Tray 1 from the printer.
2. Remove the two screws securing the Front Lower Cover to the printer frame and slide the Cover away from the frame. (Figure 1)

### **Replacement**

1. Slide the Front Lower Cover onto the printer frame, making sure the outside lip of the Cover is on top of the lip of the frame as shown in Figure 2.
2. Use two screws to secure the Front Lower Cover to the printer frame.
3. Reinstall Tray 1.

## RRP 9.6 Filter Assembly (PL1.1.32)

---

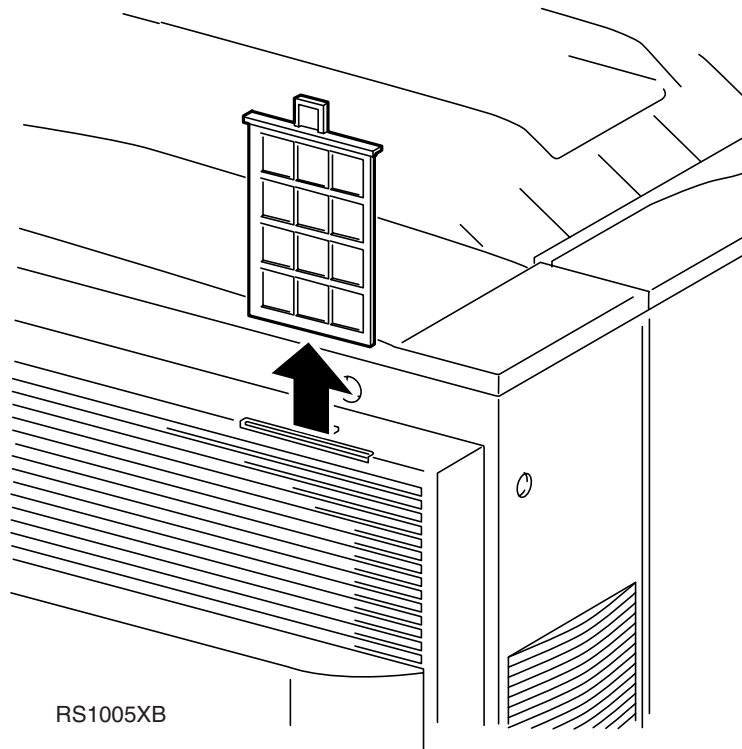

RS1005XB



## **RRP 9.6 Filter Assembly (PL1.1.32)**

---

### **Removal**

1. Press the Filter release tab as you pull up on the Filter.
2. Slide the Filter out of the slot in the Rear Cover.

### **Replacement**

1. Position the Filter at the opening of the slot in the Rear Cover, making sure the release tab at the top of the Filter faces the latch on the Rear Cover.
2. Press the Filter release tab as you slide the Filter into the slot.
3. When the Filter bottoms out, release the tab making sure the tab hooks into the latch on the Rear Cover.

## RRP 9.7 Left Lower Cover (PL1.1.40)

---

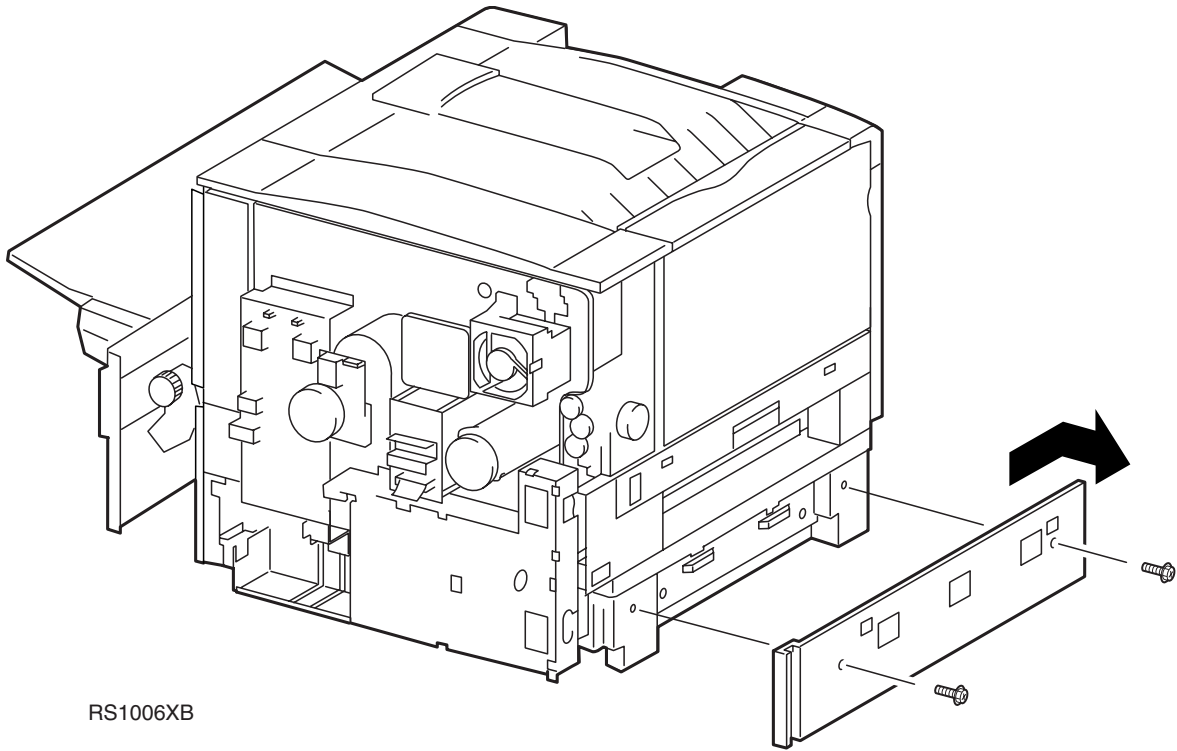

RS1006XB

RS1006XB

## **RRP 9.7 Left Lower Cover (PL1.1.40)**

---

### **Removal**

1. Remove the two screws securing the Left Lower Cover to the printer frame.
2. Lift the Cover and pull the front of the Cover away from the front of the printer frame and remove the Cover.

### **Replacement**

1. Position the Left Lower Cover against the printer frame.
2. Reposition the Cover so the two screw holes in the Cover line up with the two screw holes in the printer frame.
3. Use two screws to secure the Left Lower Cover to the printer frame.
4. Slide the Fuser Assembly into the printer.

## RRP 9.8 Right Cover Assembly (PL1.1.50)

---

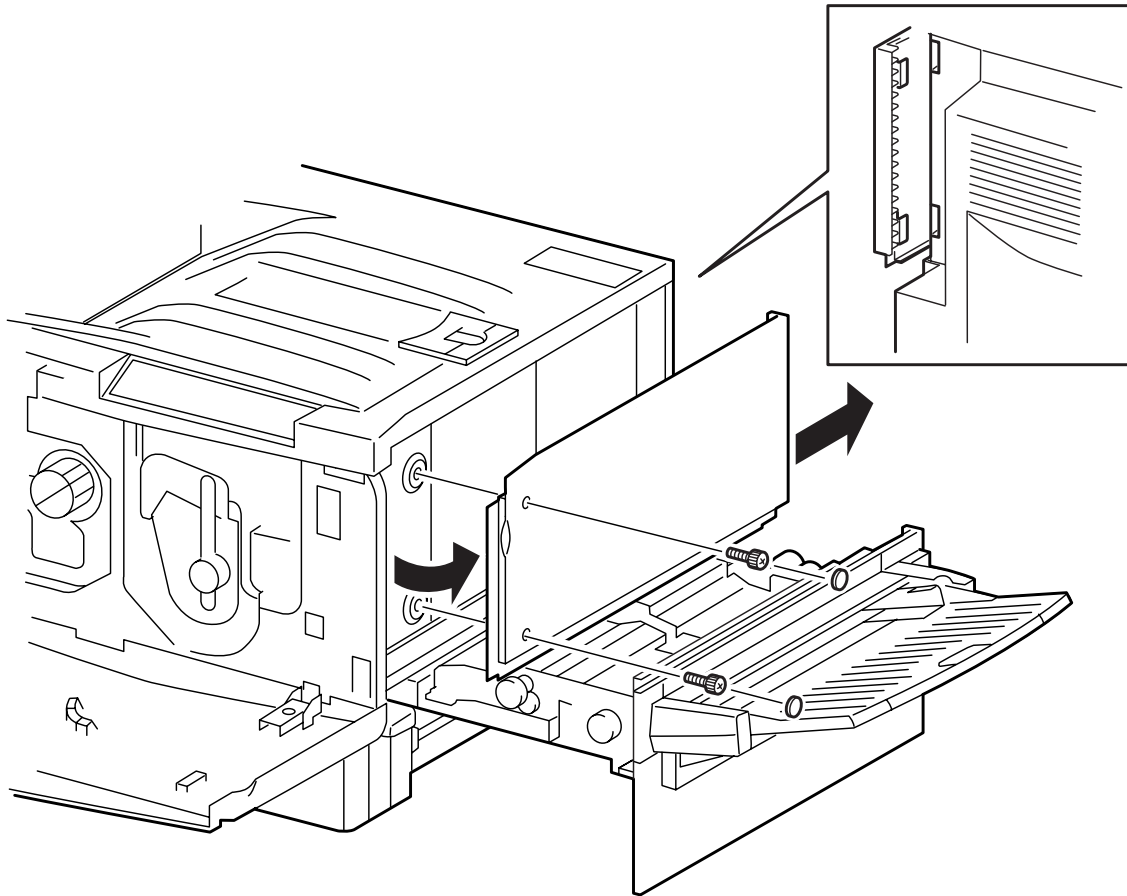

RS1007XB

RS1007XB

## **RRP 9.8 Right Cover Assembly (PL1.1.50)**

---

### **Removal**

1. Slide the Main Paper Handling Assembly a few inches out of the printer.
2. Open the Front Cover.
3. Remove the two screw caps that are covering the heads of the two Right Cover screws.
4. Remove the two screws securing the Right Cover to the printer frame.
5. Slide the Cover to the rear of the printer and remove the Cover.

### **Replacement**

1. Slide the Main Paper Handling Assembly a few inches out of the printer.
2. Open the Front Cover.
3. Insert the two metal tabs located at the rear of the Cover into the two slots in the printer frame.
4. Slide the Cover to the front of the printer.
5. Press the Cover against the printer frame, making sure the positioning tab located at the top front of the Cover fits into the hole in the printer frame.
6. Reposition the Cover so the two screw holes in the Cover line up with the two screw holes in the frame.
7. Use two screws to secure the Cover to the printer frame.
8. Reinstall the screw caps to cover the screw heads.
9. Close the Front Cover.
10. Slide the Main Paper Handling Assembly into the printer.

## RRP 9.9 Operation Panel (PL1.1.60)

---

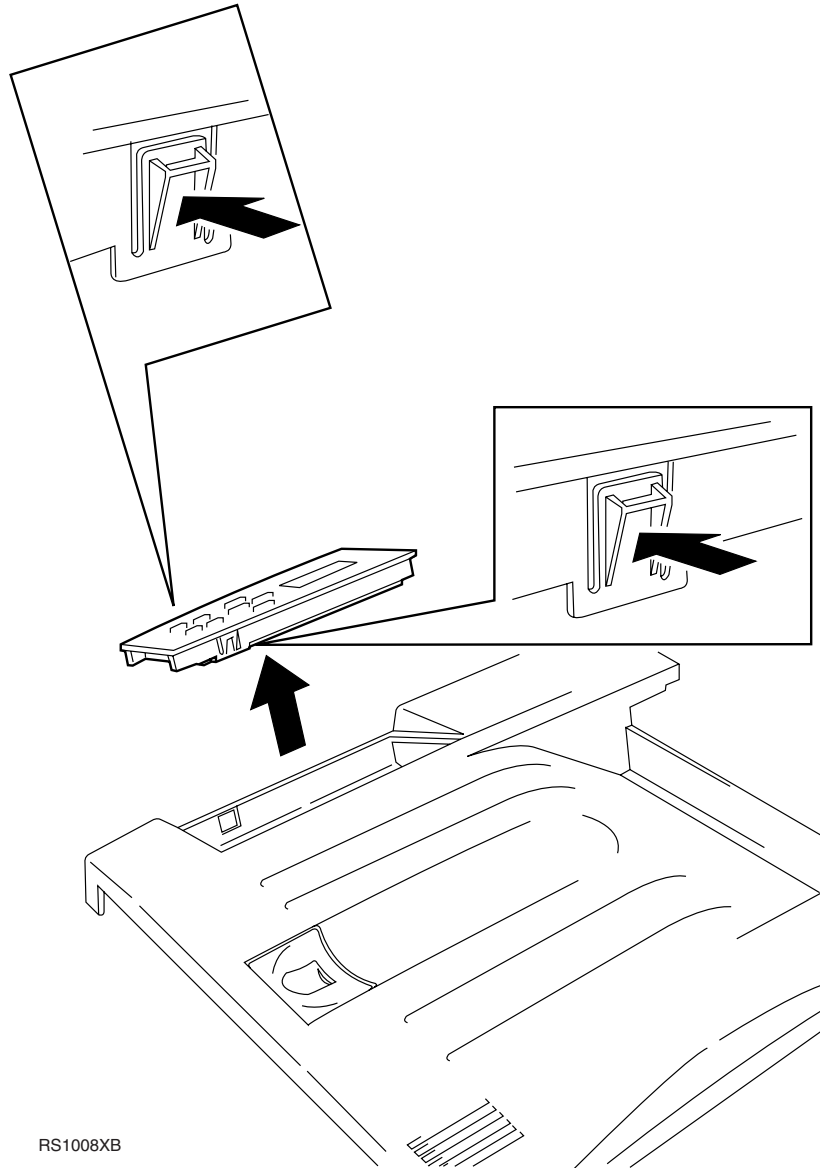

RS1008XB

RS1008XB

## **RRP 9.9 Operation Panel (PL1.1.60)**

---

### **Removal**

1. Remove the Top Cover Assembly (RRP 9.3).
2. Disconnect the Operation Panel P/J.
3. Press the tabs that are located on the sides of the Operation Panel while you push the Panel out of the Top Cover.

### **Replacement**

1. Position the Operation Panel as shown in the figure.
2. Press the Operation Panel into the opening in the Top Cover.  
The Panel snaps into place.
3. Reconnect the Operation Panel P/J.
4. Reinstall the Top Cover Assembly (RRP 9.3).

## RRP 9.10 Front Snubber (PL2.2.9)

---

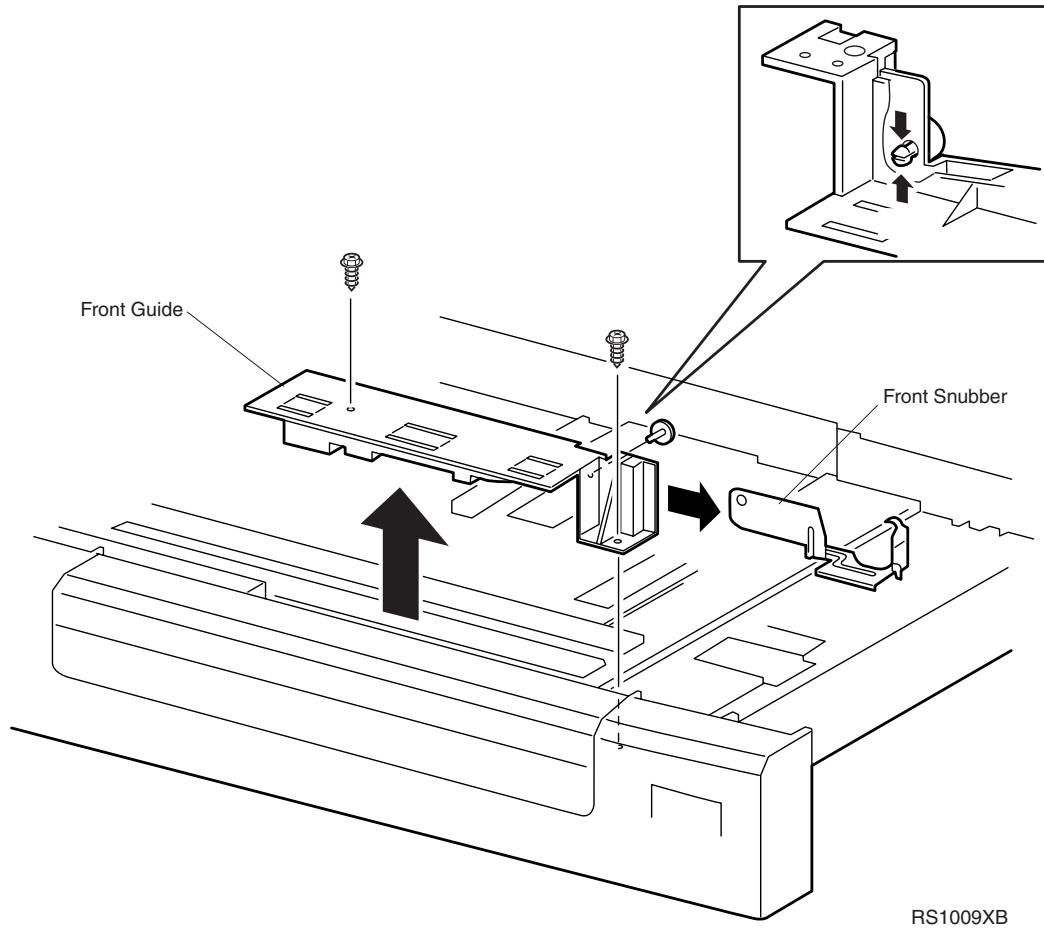

RS1009XB



## **RRP 9.10 Front Snubber (PL2.2.9)**

---

### **Removal**

1. Remove Tray 1 from the printer.
2. Remove the two screws securing the Front Guide to the Tray.
3. Remove the Guide, along with the attached Front Snubber, from the Tray.
4. Squeeze the end of the plastic fastener securing the Front Snubber to the Guide and remove the fastener.
5. Remove the Front Snubber from the Front Guide.

### **Replacement**

1. Position the Front Snubber against the Front Guide, making sure the hole in the Snubber lines up with the hole in the Guide.
2. Slide the through the hole in the Front Snubber and press firmly until the fastener locks into place.
3. Slide the Snubber under the Bottom Plate Assembly, and hook the Snubber Latch through the cutout in the side of the Tray.
4. Position the Front Guide so the tabs in the Tray fit through the cutouts in the Guide.
5. Reposition the Front Guide so the two screw holes in the Guide line up with the two screw holes in the Tray.
6. Use two screws to secure the Front Guide to the Tray.
7. Reinstall Tray 1 into the printer.

## RRP 9.11 End Guide (PL2.2.16)

---

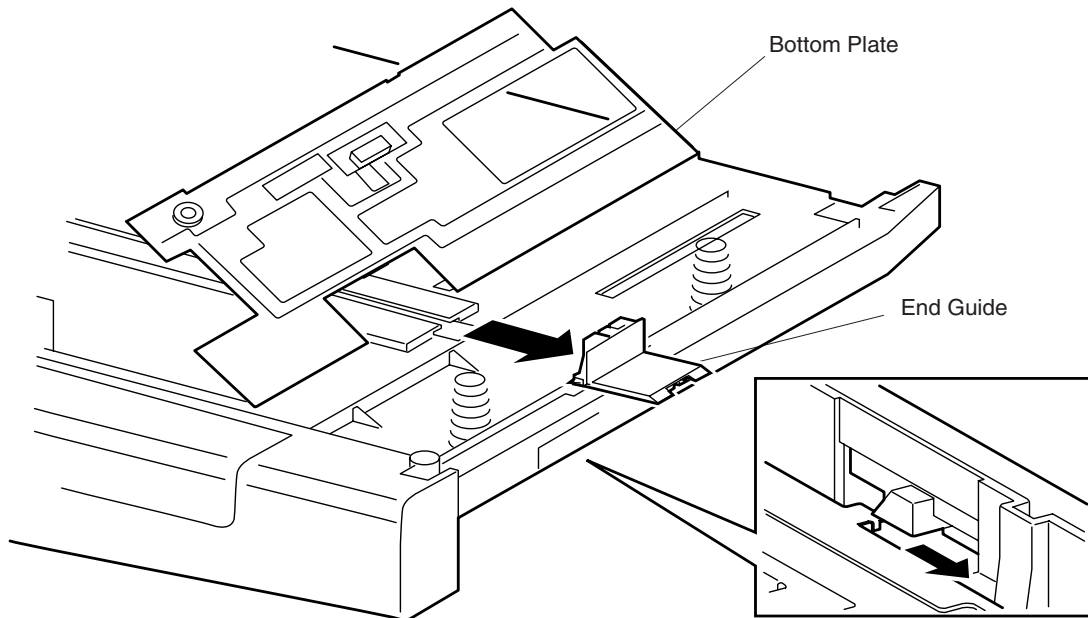

RS1011XB

RS1011XB

## **RRP 9.11 End Guide (PL2.2.16)**

---

### **Removal**

1. Remove Tray 1 from the printer.
2. Position the Tray so the bottom faces up.
3. Remove the Sector Gear (RRP 9.12).
4. Raise the Bottom Plate.
5. Squeeze the End Guide handles and slide the End Guide to the end of the guide track and remove the End Guide.

### **Replacement**

1. Raise the Bottom Plate.
2. Insert the End Guide knob into the end of the guide track.
3. Squeeze the End Guide handles and slide the End Guide onto the track.
4. Position the Tray so the bottom faces up.
5. Reinstall the Sector Gear (RRP 9.12).
6. Squeeze the End Guide handles and slide the End Guide back and forth to make sure it moves smoothly in the guide track and that the Sector Gear moves smoothly against the Tray Size Actuator.
7. Reinstall the Bottom Cover to the Tray.
8. Use five screws to secure the Bottom Cover to the Tray.
9. Reinstall Tray 1 into the printer.

## RRP 9.12 Sector Gear (PL2.2.17)

---

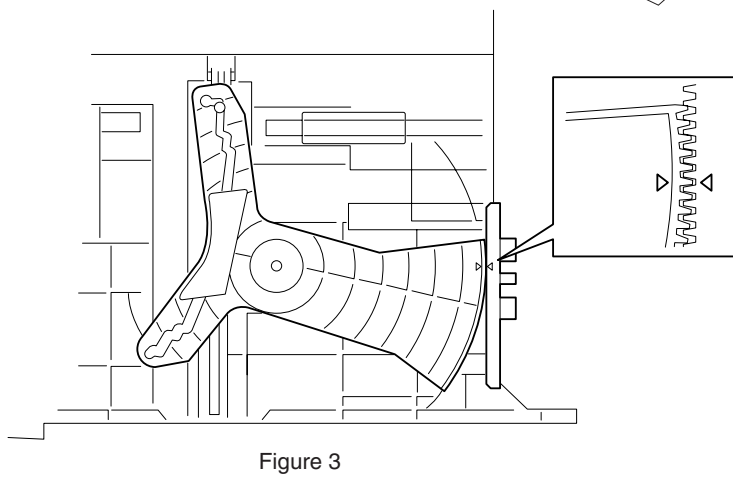
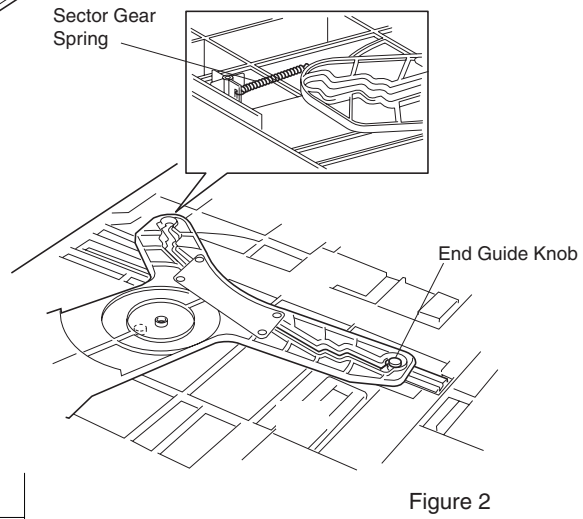
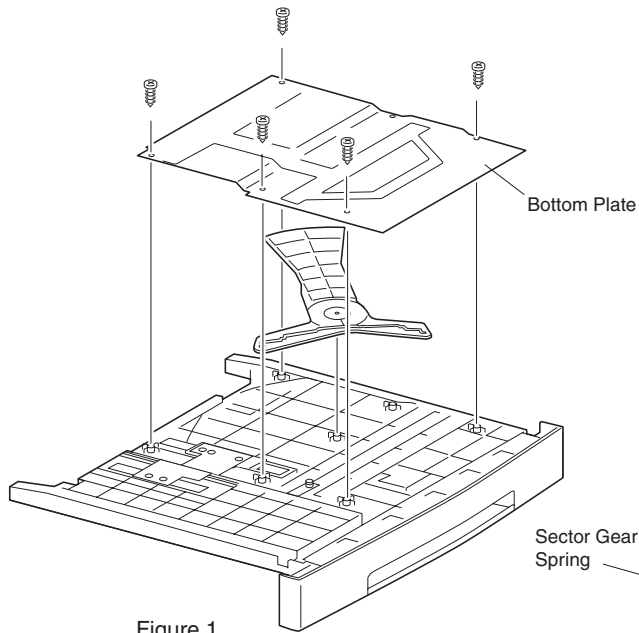

RS1012XB

RS1012XB

## **RRP 9.12 Sector Gear (PL2.2.17)**

---

### **Removal**

1. Remove Tray 1 from the printer.
2. Position the Tray so the bottom faces up.
3. Remove the five screws securing the Bottom Cover to the Tray and remove the Bottom Cover (Figure 1).
4. Remove the Sector Gear Spring from the Sector Gear (Figure 2).
5. Slide the Sector Gear so it is free of the End Guide knob and remove the Sector Gear.

### **Replacement**

1. Position Tray 1 so the bottom faces up.
2. Place the round opening that is located on one arm of the Sector Gear over the End Guide knob.
3. Reposition the Sector Gear so the round tab on the bottom of the Tray fits through the hole located in the center of the Sector Gear, making sure the End Guide knob remains attached to the arm of the Sector Gear.
4. Press the Sector Gear against the bottom of the Tray, making sure the gear teeth mesh with the teeth Tray Size Actuator and the positioning mark on the Gear lines up with the positioning mark on the Size Actuator (Figure 3).
5. Squeeze the End Guide handles and slide the End Guide back and forth to make sure it moves smoothly in the guide track and that the Sector Gear moves smoothly against the Tray Size Actuator.
6. Reinstall the Sector Gear Spring onto the end of the Sector Gear.
7. Reinstall the Bottom Cover to the Tray.
8. Use five screws to secure the Bottom Cover to the Tray.
9. Reinstall Tray 1 into the printer

## RRP 9.13 Feed Roll Assembly (PL3.1.1)

---

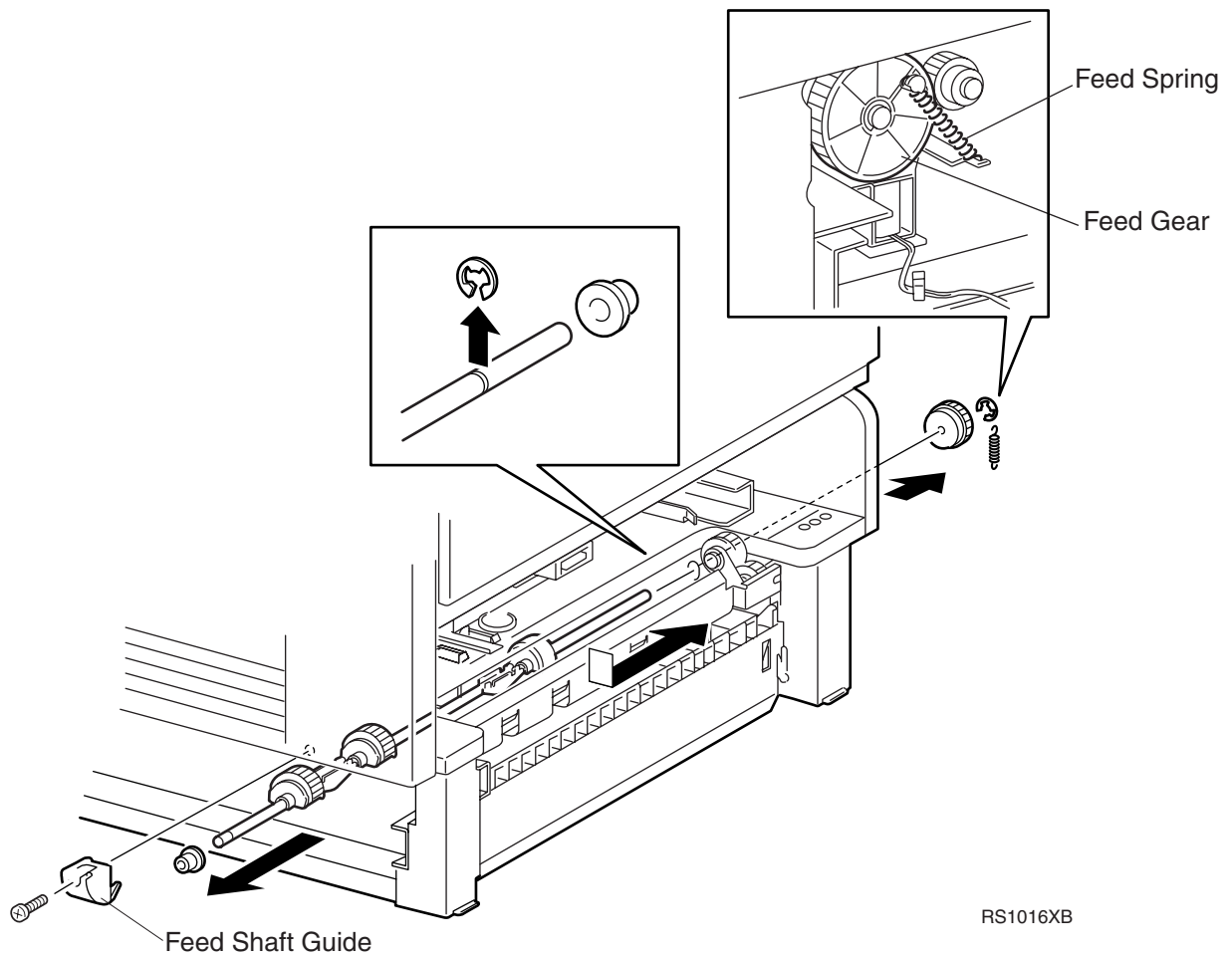

RS1016XB

## **RRP 9.13 Feed Roll Assembly (PL3.1.1)**

---

### **Removal**

1. Remove Tray 1 from the printer.
2. Remove the Rear Cover (RRP 9.4)
3. Remove the Main Paper Handling Assembly (RRP 9.36).
4. Remove the two screws securing the Turn Chute to the printer frame and remove the Turn Chute.
5. Remove the two screws securing the Option Plug/Jack Bracket to the rear of the printer frame and pull the Bracket away from the frame so you can access the Feed Gear.
6. Remove the Feed Spring from the Feed Gear.
7. Remove the E ring securing the Feed Gear to the Feed Shaft and remove the Gear.
8. Remove the screw securing the Feed Shaft Guide to the front of the frame and remove the Guide.
9. Remove the Front Feed Roll (RRP 9.14).
10. Rotate the Feed Shaft so the Rear Feed Roll clears the No Paper Bracket and slide the rear of the Shaft out of the rear bearing.
11. Slide the front of the Shaft out of the front bearing and remove the Shaft.

### **Replacement**

1. Remove the Front Feed Roll from the Feed Shaft (RRP 9.14).
2. Slide the front bearing onto the end of the Feed Shaft.
3. Slide the front of the Shaft through the cutout in the front of the frame.
4. Push the Shaft far enough through the cutout so you can insert the rear bearing, attached to the rear of the Shaft, into the cutout in the rear of the frame.
5. Slide the front bearing along the front of the Shaft and insert it into the cutout in the front of the frame.
6. Reinstall the Feed Shaft Guide onto the printer frame and over the front end of the Feed Shaft, and use one screw to secure the Guide.
7. Reinstall the Front Feed Roll (RRP 9.14).
8. Rotate the Shaft so the Feed Rolls are up.
9. Hold the Feed Shaft in position and push down on the Feed Solenoid arm as you slide the Feed Gear onto the rear of the Shaft.
10. Use an E ring to secure the Feed Gear to the Shaft.
11. Reinstall the Feed Spring, with one end attached to the frame and the other attached to the tab on the Feed Gear.
12. Reinstall the Option Plug/Jack Bracket onto the rear of the printer frame.
13. Use two screws to secure the Option Plug/Jack Bracket to the frame.
14. Reinstall the Turn Chute onto the printer frame, making sure you slide the bottom of the Chute under the Turn Roll Assembly so the four Turn Rolls fit through the opens in the Chute.
15. Use two screws to secure the Turn Chute to the printer frame.
16. Reinstall the Main Paper Handling Assembly (RRP 9.36).
17. Reinstall the Rear Cover (RRP 9.4).
18. Reinstall Tray 1 into the printer.

## RRP 9.14 Feed Roll (PL3.1.3)

---

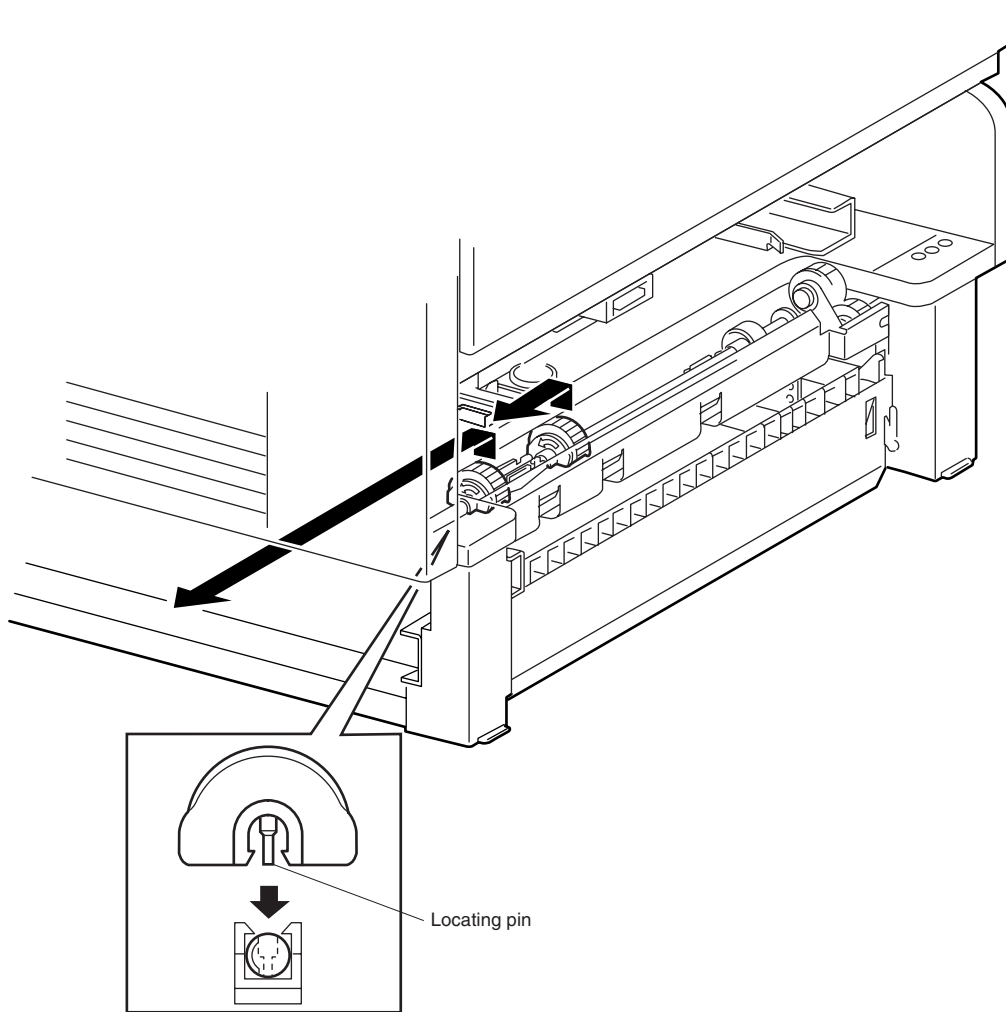

RS1013XB

RS1013XB



## RRP 9.14 Feed Roll (PL3.1.3)

---

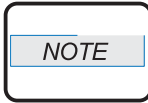

*We recommend that you replace Feed Rolls as a set.*

### Removal

1. Remove Tray 1 from the printer.
2. Remove the Main Paper Handling Assembly (RRP 9.36).
3. Remove the two screws securing the Turn Chute to the printer frame and remove the Turn Chute.
4. Reach in through the empty paper feeder and spread the plastic arms of the Front Feed Roll as you lift the Roll off of the shaft.
5. Reach in through the empty paper feeder and spread the plastic arms of the Rear Feed Roll as you lift the Roll off of the shaft.

### Replacement

1. Remove Tray 1 from the printer.
2. Remove the Main Paper Handling Assembly (RRP 9.36).
3. Remove the two screws securing the Turn Chute to the printer frame and remove the Turn Chute.
4. Position the Rear Feed Roll as shown in the figure.
5. Line up the locating pin on the Feed Roll with the hole in the shaft.
6. Reach in through the empty paper feeder and use your hand to support the shaft as you press the Rear Feed Roll onto the shaft.
7. Position the Front Feed Roll as shown in the figure.
8. Line up the locating pin on the Feed Roll with the hole in the shaft.
9. Reach in through the empty paper feeder and use your hand to support the shaft as you press the Front Feed Roll onto the shaft.
10. Reinstall the Turn Chute onto the printer frame, making sure you slide the bottom of the Chute under the Turn Roll Assembly so the four Turn Rolls fit through the opens in the Chute.
11. Use two screws to secure the Turn Chute to the printer frame.
12. Reinstall the Main Paper Handling Assembly (RRP 9.36).
13. Reinstall Tray 1 into the printer.

## RRP 9.15 Feed Solenoid (PL3.1.9)

---

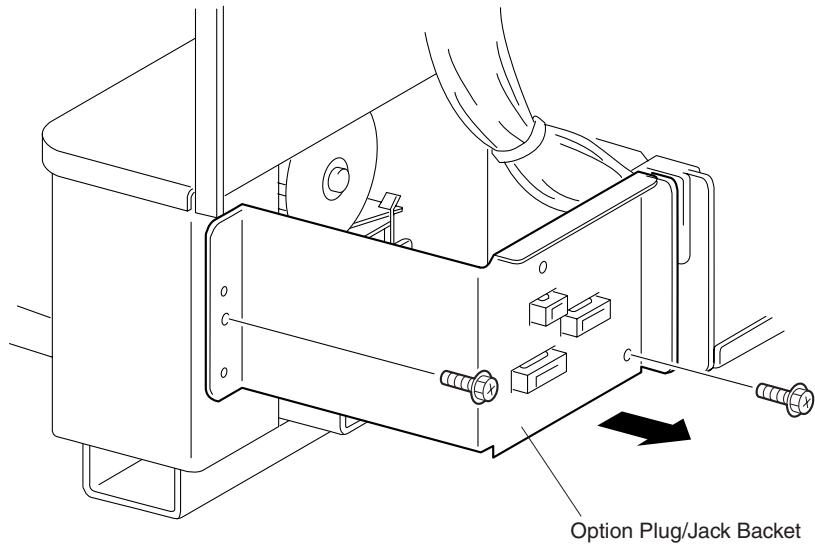

Figure 1

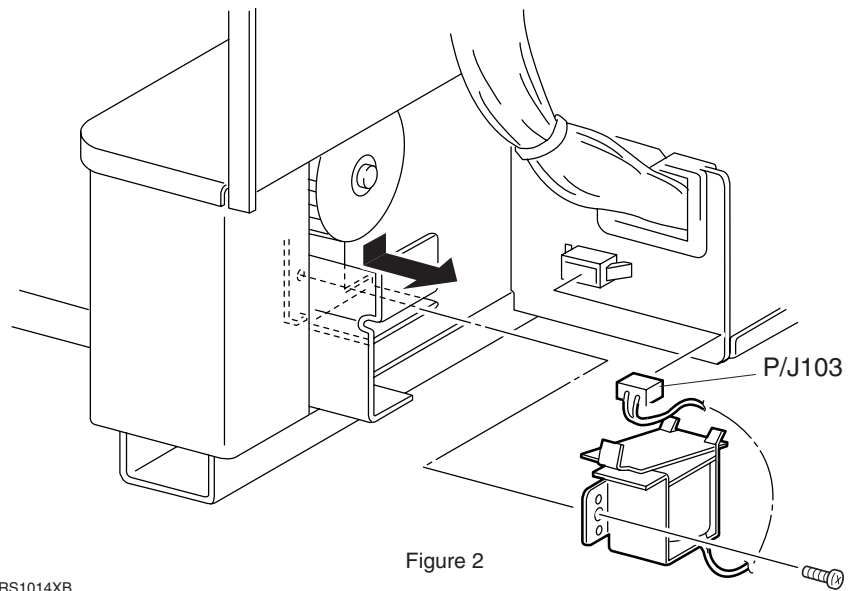

Figure 2

RS1014XB

RS1014XB

## **RRP 9.15 Feed Solenoid (PL3.1.9)**

---

### **Removal**

1. Remove the Rear Cover (RRP 9.4)
2. Remove the two screws securing the Turn Chute to the printer frame and remove the Turn Chute.
3. Remove the two screws securing the Option Plug/Jack Bracket to the rear of the printer frame and pull the Bracket away from the frame so you can access the Feed Solenoid (Figure 1).
4. Disconnect P/J 103.
5. Remove the screw securing the Feed Solenoid to the printer frame (Figure 2).
6. Push down on the Solenoid arm so the Solenoid can clear the Feed Gear and remove the Solenoid from the printer frame.

### **Replacement**

1. Push down on the Feed Solenoid arm so the Solenoid can clear the Feed Gear and reinstall the Solenoid onto the printer frame.
2. Use one screw to secure the Solenoid to the printer frame.
3. Reconnect P/J 103.
4. Reinstall the Option Plug/Jack Bracket onto the rear of the printer frame.
5. Use two screws to secure the Option Plug/Jack Bracket to the frame.
6. Reinstall the Turn Chute onto the printer frame, making sure you slide the bottom of the Chute under the Turn Roll Assembly so the four Turn Rolls fit through the opens in the Chute.
7. Use two screws to secure the Turn Chute to the printer frame.
8. Reinstall the Rear Cover (RRP 9.4).

## RRP 9.16 Turn Roll Assembly (PL3.1.11)

---

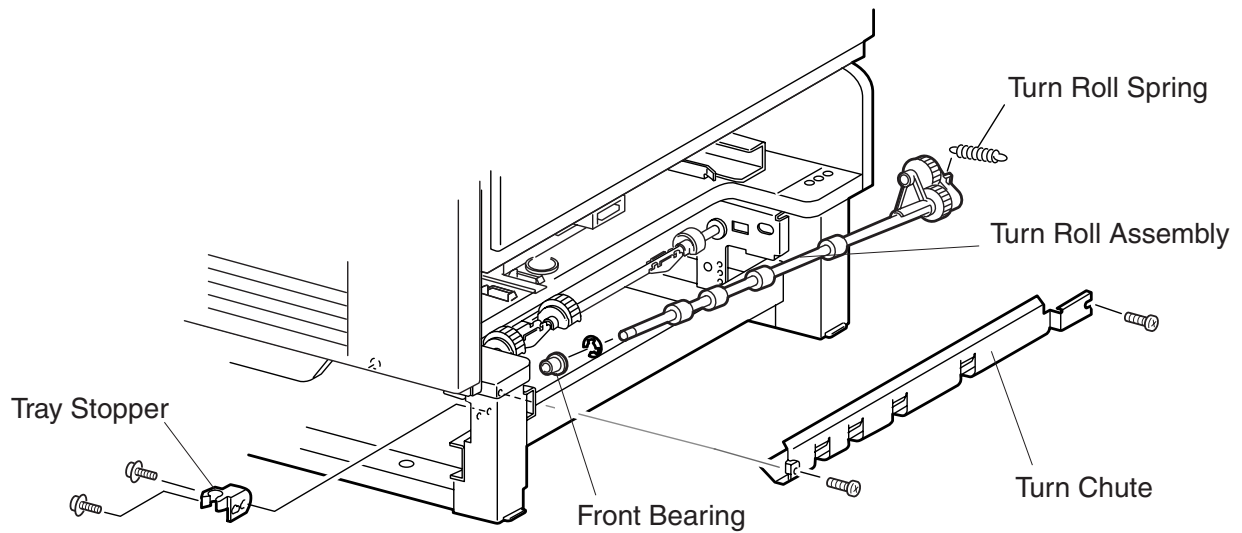

RS1015XB

RS1015XB

## **RRP 9.16 Turn Roll Assembly (PL3.1.11)**

---

### **Removal**

1. Remove Tray 1 from the printer.
2. Remove the Main Paper Handling Assembly (RRP 9.36).
3. Remove the two screws securing the Turn Chute to the printer frame and remove the Turn Chute.
4. Remove the Turn IN Chute (RRP 9.20).
5. Remove the two screws securing the Tray Stopper to the printer frame and remove the Stopper.
6. Remove the E ring securing the front of the Turn Roll Shaft to the front bearing.
7. Disconnect the Turn Arm Spring from the printer frame.
8. Remove the E ring securing the round cover that is over the Turn Arm Assembly Gear and remove the cover.
9. Slide the rear of the Turn Roll Shaft out of the Turn Arm Assembly.
10. Slide the front of the Turn Roll Shaft out of the front bearing and remove the Turn Roll Assembly.

### **Replacement**

1. Slide the front bearing over the front of the Turn Roll Shaft.
2. Slide the front of the Turn Roll Shaft through the cutout in the front of the frame.
3. Push the Shaft far enough through the cutout so you can slide the rear of Shaft into the Turn Arm Assembly.
4. Reinstall the round cover over the Turn Arm Assembly Gear and use an E ring to secure the cover to the Gear.
5. Reconnect the Turn Arm Spring to the printer frame.
6. Use an E ring to secure the front of the Turn Roll Shaft to the front bearing.
7. Reinstall the Tray Stopper to the printer frame and use two screws to secure the Stopper to the frame.
8. Reinstall the Turn IN Chute (RRP 9.20).
9. Push in on the rear arm of the Turn IN Chute and insert the arm into the hole in the rear of the frame.
10. Reinstall the Turn Chute onto the printer frame, making sure you slide the bottom of the Chute under the Turn Roll Assembly so the four Turn Rolls fit through the opens in the Chute.
11. Use two screws to secure the Turn Chute to the printer frame.
12. Reinstall the Main Paper Handling Assembly (RRP 9.36).
13. Reinstall Tray 1 into the printer.

## RRP 9.17 Size Switch Assembly (PL3.1.23)

---

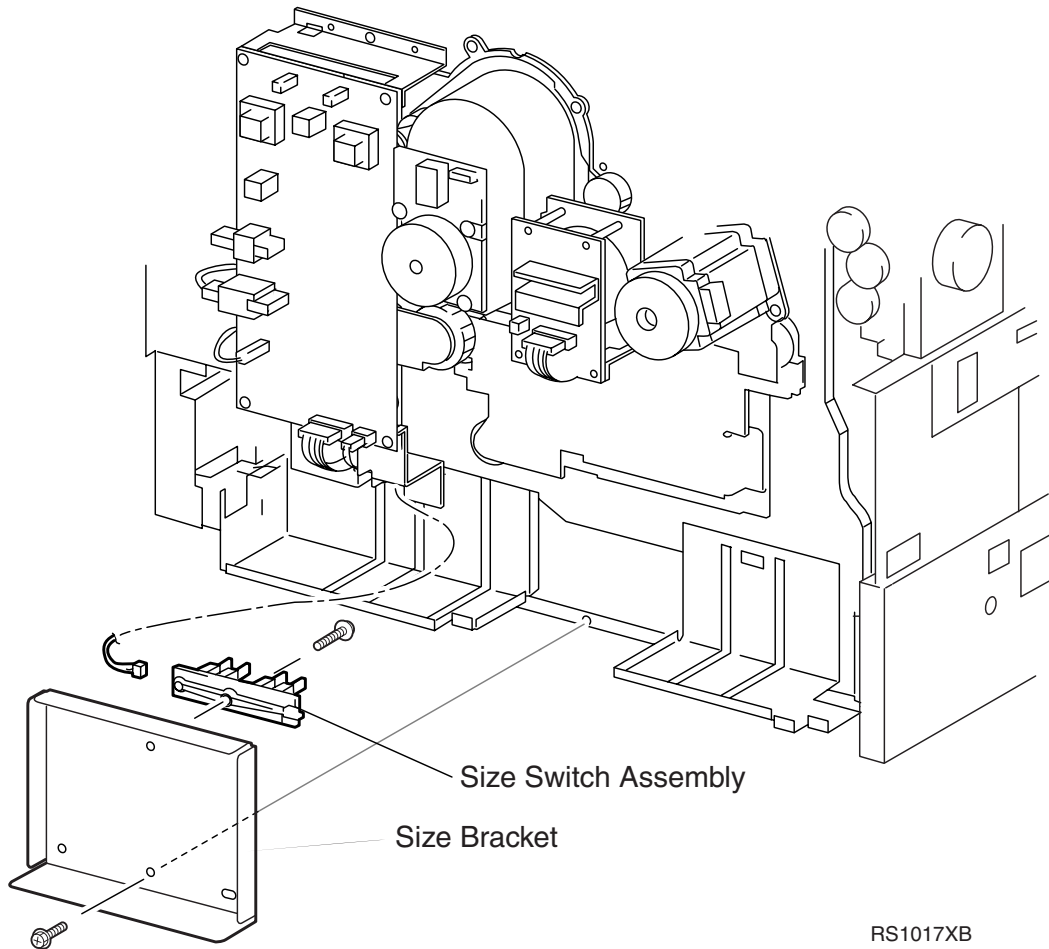

RS1017XB

## **RRP 9.17 Size Switch Assembly (PL3.1.23)**

---

### **Removal**

1. Remove the LVPS (RRP 9.119).
2. Remove the screw securing the Size Bracket to the printer frame and remove the Bracket.
3. Disconnect P/J 102 from the Size Switch PWB.
4. Remove the screw securing the Size Switch PWB to the Size Bracket and remove the PWB.

### **Replacement**

1. Reinstall the Size Switch PWB onto the Size Bracket, making sure you line up the two plastic tabs at the back of the PWB with the two holes in the Bracket.
2. Use one screw to secure the PWB to the Size Bracket.
3. Reconnect P/J 102 to the Size Switch PWB.
4. Reinstall the Size Bracket onto the printer frame and use one screw to secure the Bracket.
5. Reinstall the LVPS (RRP 9.119).

## RRP 9.18 No Paper Sensor Assembly (PL3.1.30)

---

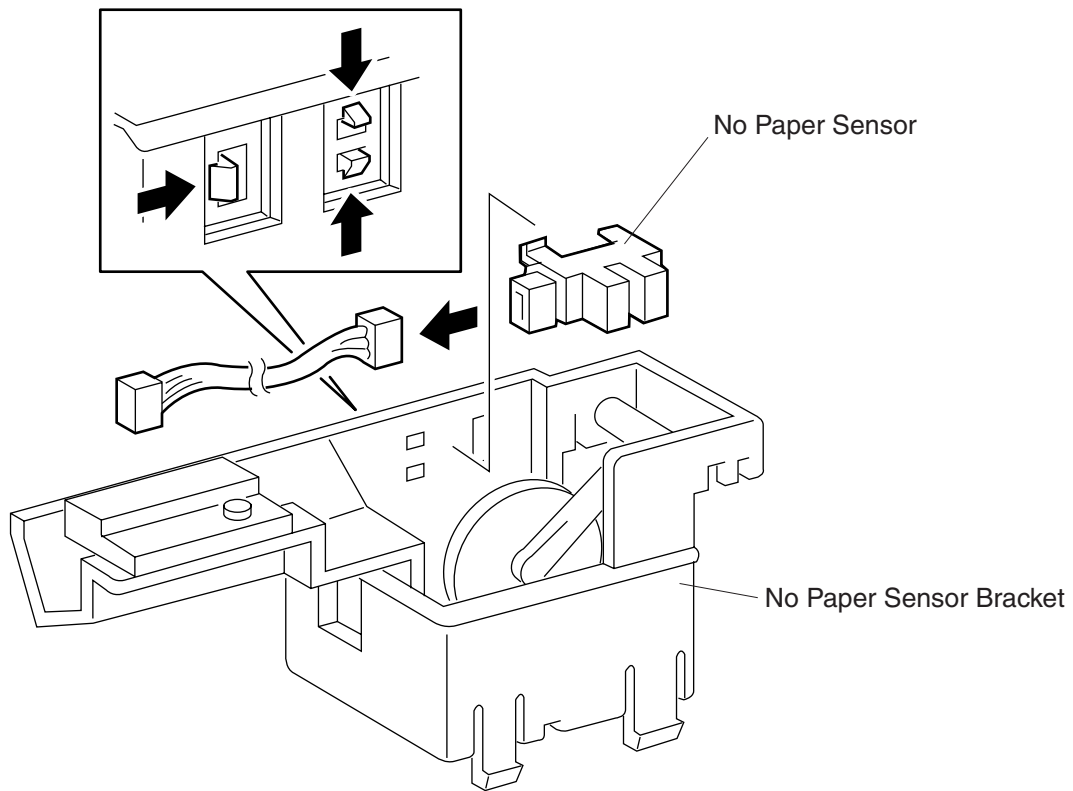

RS1018XB

RS1018XB



## **RRP 9.18 No Paper Sensor Assembly (PL3.1.30)**

---

### **Removal**

1. Remove Tray 1 from the printer.
2. Remove the Main Paper Handling Assembly (RRP 9.36).
3. Reach in through the empty paper feeder and hold onto the No Paper Sensor Bracket.
4. With the other hand reach in through the empty Paper Handling Assembly cavity and push in on the latches holding the No Paper Sensor Bracket to the printer frame.
5. When you have released the latch, pull the Bracket down into the empty paper feeder.
6. Disconnect P/J107 from the No Paper Sensor.
7. Squeeze in on the latches securing the Sensor to the Bracket and remove the Sensor.

### **Replacement**

1. Position the Sensor so the P/J face the Low Paper Sensor.
2. Press the Sensor onto the Bracket until the Sensor latches snap into place.
3. Reconnect P/J 107 to the No Paper Sensor.
4. Reinstall the No Paper Bracket by inserting the latches of the Bracket up into the two cutouts in the printer frame.
5. Push in on the latches and push up on the Bracket until the latches lock into place.
6. Reinstall the Main Paper Handling Assembly (RRP 9.36).
7. Reinstall Tray 1 into the printer.

## RRP 9.19 Low Paper Sensor (PL3.1.35)

---

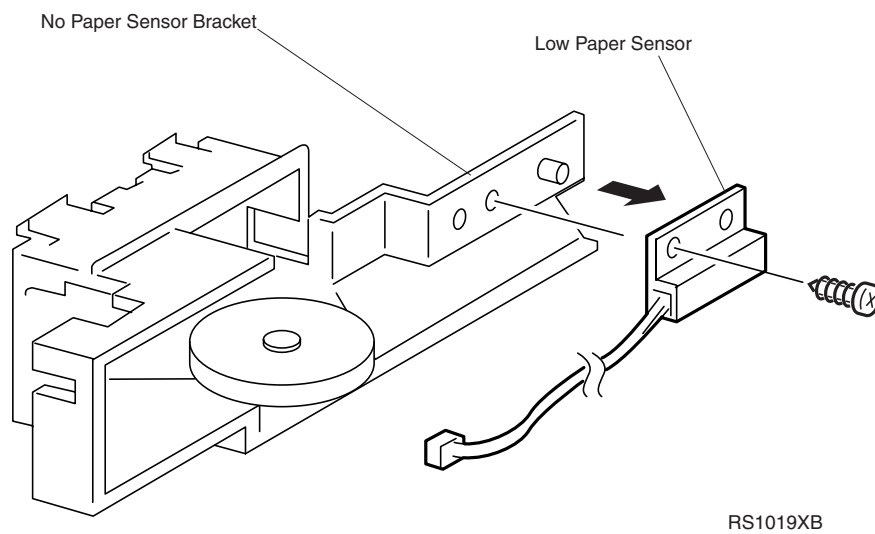

RS1019XB

## **RRP 9.19 Low Paper Sensor (PL3.1.35)**

---

### **Removal**

1. Remove Tray 1 from the printer.
2. Remove the Main Paper Handling Assembly (RRP 9.36).
3. Reach in through the empty paper feeder and hold onto the No Paper Bracket.
4. With the other hand reach in through the empty Paper Handling Assembly cavity and push in on the four latches holding the No Paper Bracket to the printer frame.
5. When you have released the latch, pull the Bracket down into the empty paper feeder.
6. Follow the wire coming out of the Low Paper Sensor and disconnect it from P/J106.
7. Remove the screw securing the Low Paper Sensor to the No Paper Bracket and remove the Sensor.

### **Replacement**

1. Position the Low Paper Sensor against the No Paper Bracket so the Sensor wires are face the rear of the printer.
2. Reposition the Sensor so the two holes in the Sensor line up with the screw hole and positioning tab on the No Paper Bracket.
3. Use one screw to secure the Sensor to the Bracket.
4. Route the Sensor wire through the grommet hole in the frame, and reconnect the Sensor to P/J106.
5. Reinstall the No Paper Bracket by inserting the four latches of the Bracket up into the two cutouts in the printer frame.
6. Push in on the latches and push up on the Bracket until the latches lock into place.
7. Reinstall the Main Paper Handling Assembly (RRP 9.36).
8. Reinstall Tray 1 into the printer.

## RRP 9.20 Turn IN Chute (PL3.1.18)

---

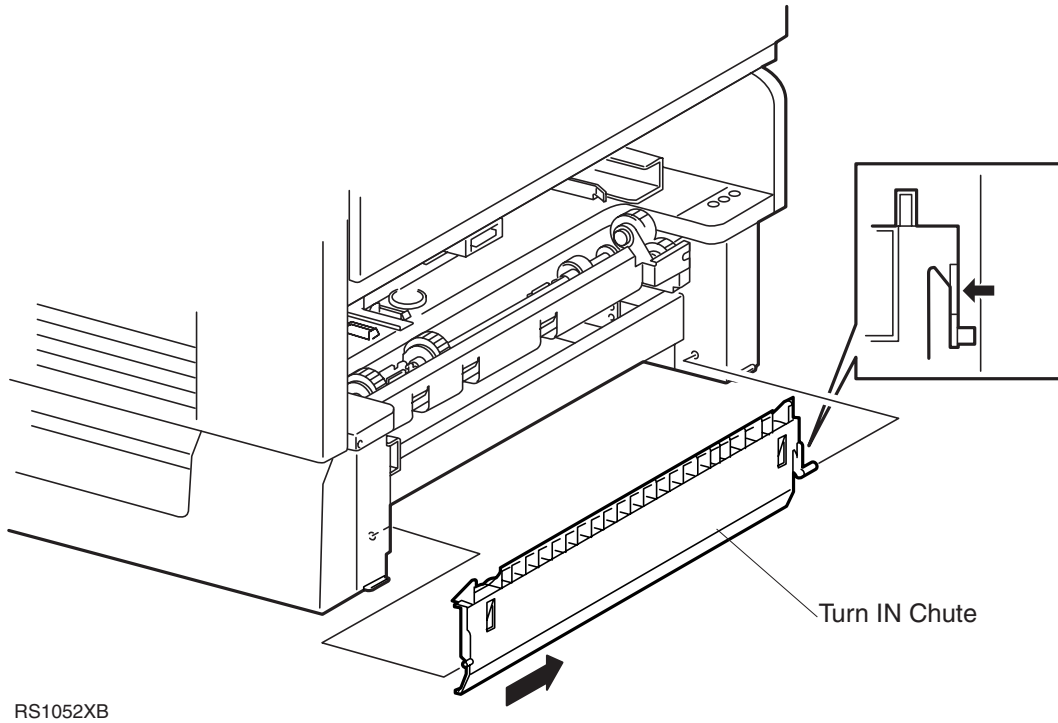

RS1052XB

RS1052XB

## **RRP 9.20 Turn IN Chute (PL3.1.18)**

---

### **Removal**

1. Remove the Main Paper Handling Assembly (RRP 9.36).
2. Press the rear pivot arm of the Turn IN Chute away from the printer frame and remove the arm from the pivot hole in the rear of the printer frame.
3. Slide the Turn IN Chute to the rear of the printer and free the front pivot arm from the pivot hole in the front of the printer frame.

### **Replacement**

1. Insert the front pivot arm of the Turn IN Chute into the pivot hole in the front of the printer frame.
2. Press the rear pivot arm of the Turn IN Chute and insert the rear pivot arm into the pivot hole in the rear of the printer frame.
3. Reinstall the Main Paper Handling Assembly (RRP 9.36).

## RRP 9.21 Universal Paper Tray (PL2.1.1)

---

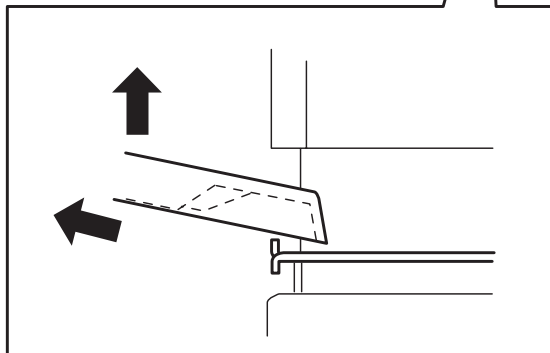
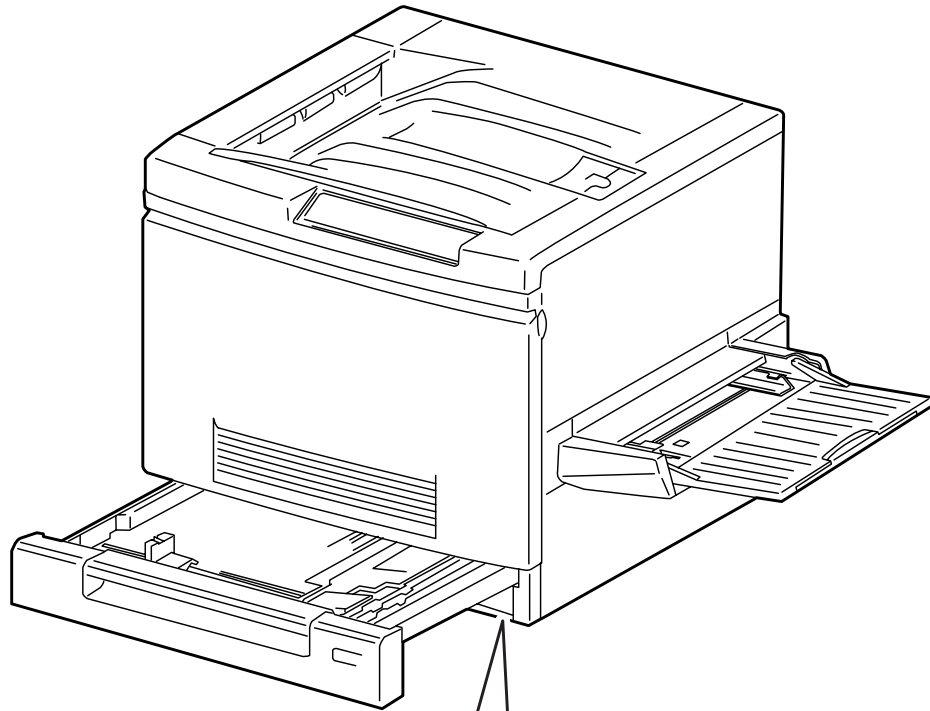

RS1053XB

RS1053XB

## **RRP 9.21 Universal Paper Tray (PL2.1.1)**

---

### **Removal**

1. Slide the Universal Paper Tray (Tray 1) out of the printer until the Tray stops.
2. Lift the front of the Tray and remove it from the printer.

### **Replacement**

1. Hold the Tray so the front is raised and insert the rear of the Tray into the printer.
2. Push the Tray in about an inch then lower the front so the Tray is horizontal and push the Tray all the way into the printer.

## RRP 9.22 MSI Assembly (PL4.1.1)

---

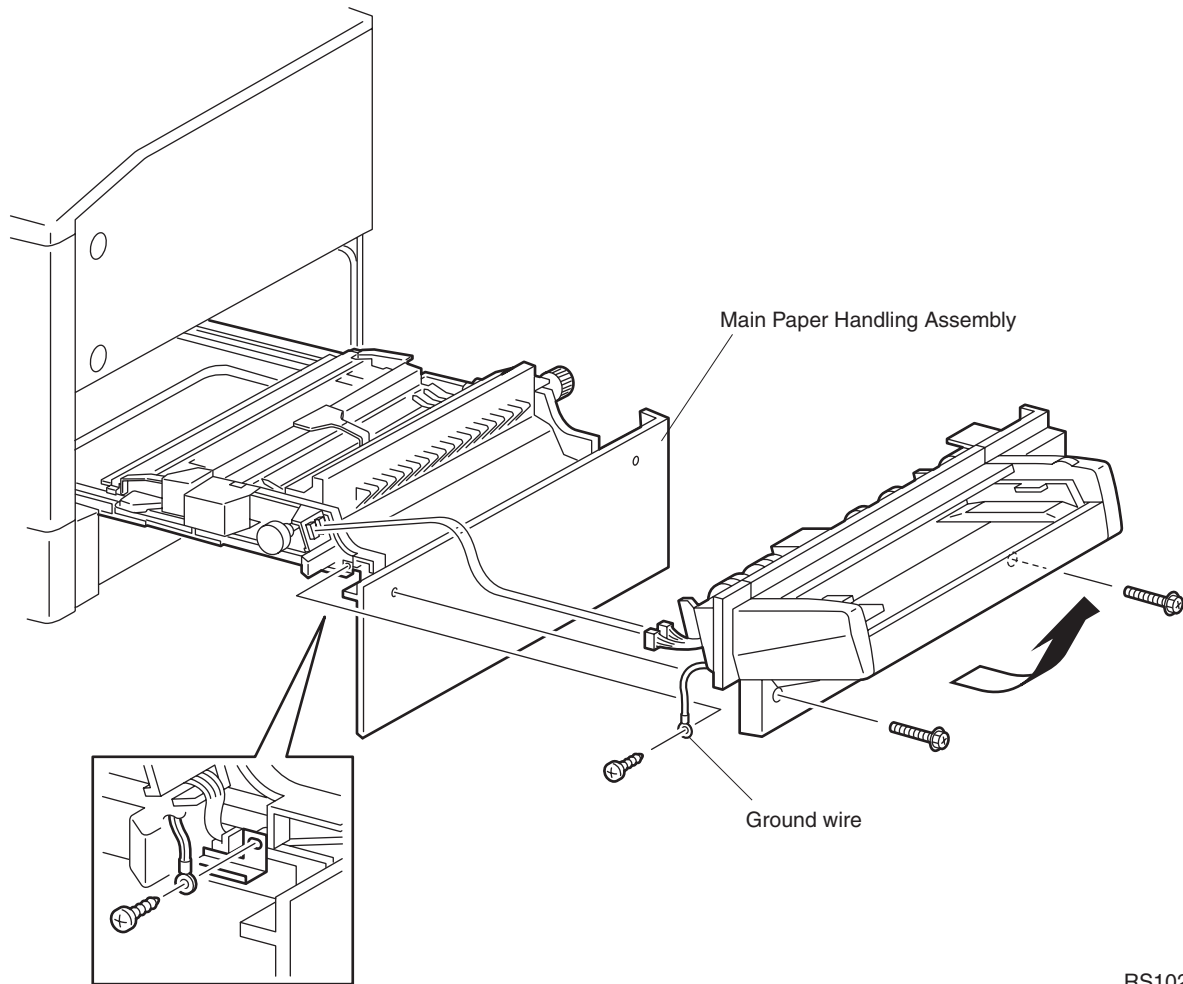

RS1020XC

RS1020XC



## **RRP 9.22 MSI Assembly (PL4.1.1)**

---

### **Removal**

1. Remove the two screws securing the MSI Assembly to the Main Paper Handling Assembly.
2. Open the Main Paper Handling Assembly far enough for you to access the two P/Js that are located at the at the front of Assembly.
3. Disconnect P/Js 91 and 92.
4. If installed, remove the screw securing the ground wire to the Main Paper Handling Assembly.
5. Hold the bottom of the MSI Assembly and rotate it up and away from the Main Paper Handling Assembly.

### **Replacement**

1. Open the Main Paper Handling Assembly a few inches.
2. Reinstall the MSI Assembly onto the Main Paper Handling Assembly.  
If installed correctly, the weight of the MSI Assembly should hold it in place on the Main Paper Handling Assembly.
3. If installed, reinstall the ground wire to the Main Paper Handling Assembly and use one screw to secure the wire to the Assembly.
4. Reconnect P/Js 91 and 92.
5. Use two screws to secure the MSI Assembly to the Main Paper Handling Assembly.

## RRP 9.23 MSI Front Cover (PL4.1.3)

---

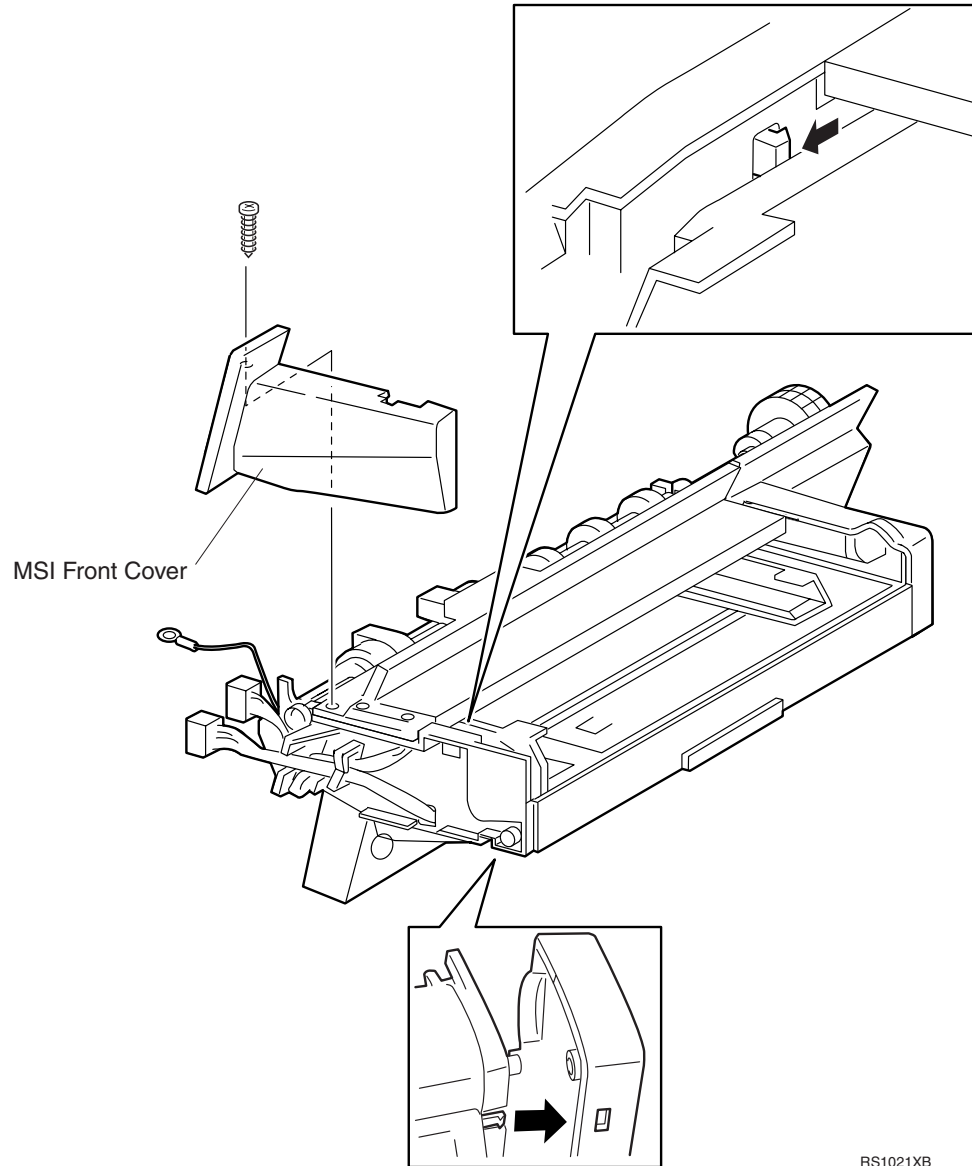

RS1021XB

RS1021XB

## **RRP 9.23 MSI Front Cover (PL4.1.3)**

---

### **Removal**

1. Remove the MSI Assembly (RRP 9.22).
2. Remove the screw securing the top of the MSI Front Cover to the MSI Frame.
3. Push down on the Cover latch while you pull the MSI Front Cover away from the MSI Frame.

### **Replacement**

1. Position the MSI Front Cover next to the MSI Frame.
2. Hook the latch that is located on the inside of the Cover, under the top lip of the MSI Frame.
3. Push the Cover onto the Frame, making sure the wire harnesses and the ground strap fit through the cutouts in the Cover.  
The Cover latch locks into place.
4. Use a screw to secure the top of the MSI Front Cover to the MSI Frame.
5. Reinstall the MSI Assembly (RRP 9.22).

## RRP 9.24 MSI Rear Cover (PL4.1.4)

---

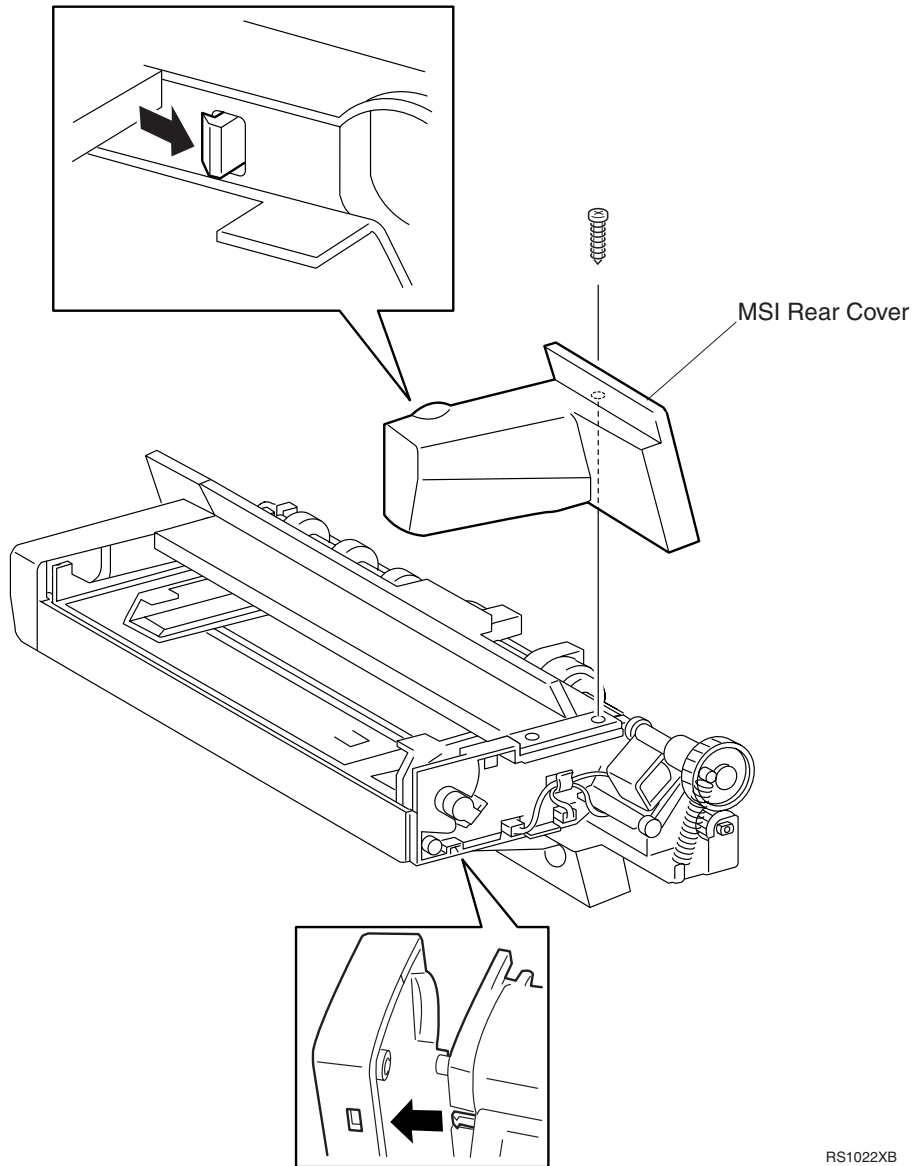

RS1022XB

## **RRP 9.24 MSI Rear Cover (PL4.1.4)**

---

### **Removal**

1. Remove the MSI Assembly (RRP 9.22).
2. Remove the screw securing the top of the MSI Rear Cover to the MSI Frame.
3. Push down on the Cover latch while you pull the MSI Rear Cover away from the MSI Frame.

### **Replacement**

1. Position the MSI Rear Cover next to the MSI Frame.
2. Hook the latch that is located on the inside of the Cover, under the top lip of the MSI Frame.
3. Push the Cover onto the Frame.  
The Cover latch locks into place.
4. Use one screw to secure the top of the MSI Rear Cover to the MSI Frame.
5. Reinstall the MSI Assembly (RRP 9.22).

## RRP 9.25 MSI Tray Assembly (PL4.1.10)

---

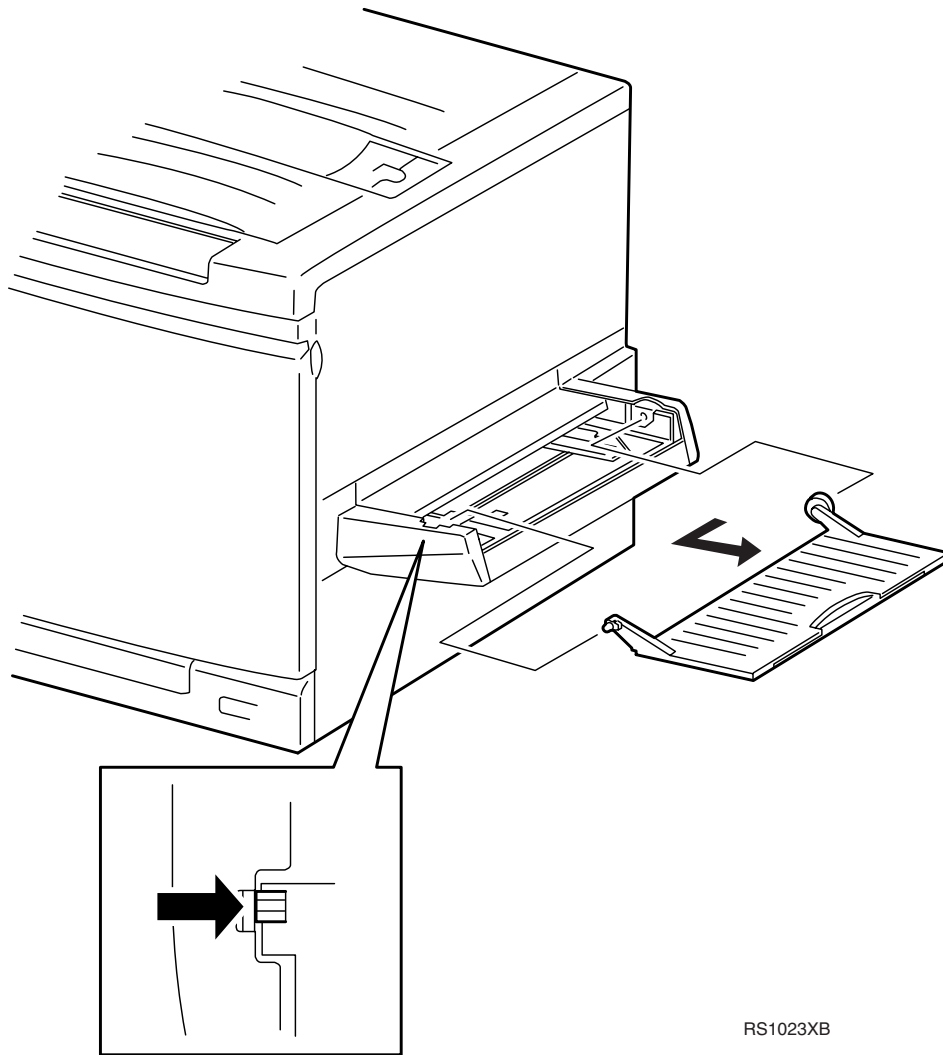

RS1023XB

RS1023XB

## **RRP 9.25 MSI Tray Assembly (PL4.1.10)**

---

### **Removal**

1. Raise the MSI Tray until it is at approximately 90° to the MSI Assembly.
2. Press in on the front arm of the MSI Tray as you pull the front of the MSI Tray free of the MSI Frame.
3. Slide the MSI Tray forward to free the rear of the MSI Tray from the MSI Frame.
4. Remove the MSI Tray Assembly.

### **Replacement**

1. Position the MSI Tray so it is at approximately 90° to the MSI Assembly.
2. Insert the rear arm (gear arm) of the MSI Tray into the rear of the MSI Frame.
3. Press in on the front arm of the MSI Tray as you insert the front arm into the front of the MSI Frame.
4. Move the Tray up and down to make sure it moves smoothly.

## RRP 9.26 MSI Top Cover Assembly (PL4.2.4)

---

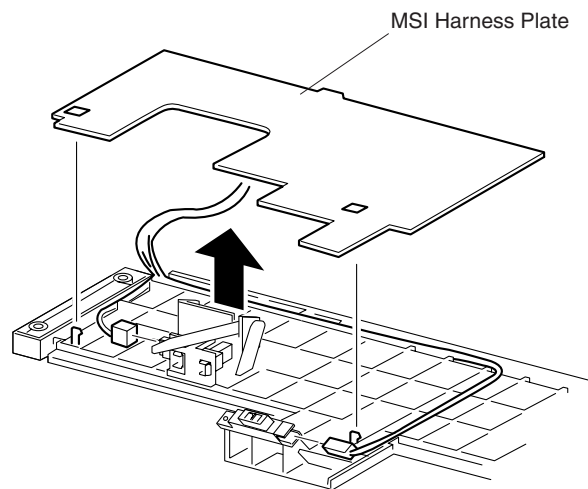
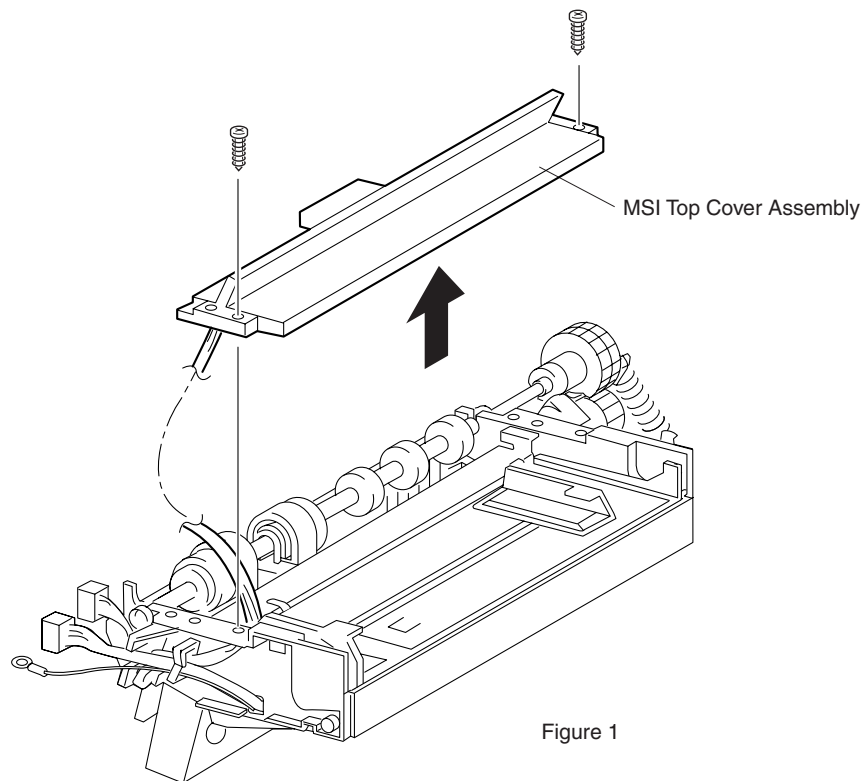

RS1024XB

RS1024XB



## **RRP 9.26 MSI Top Cover Assembly (PL4.2.4)**

---

### **Removal**

1. Remove the MSI Front Cover (RRP 9.23).
2. Remove the MSI Rear Cover (RRP 9.24).
3. Remove the two screws securing the MSI Top Cover Assembly to the MSI Frame and remove the Top Cover (Figure 1).
4. Release the two latches securing the MSI Harness Plate to the MSI Top Cover and remove the Plate (Figure 2).
5. Disconnect the P/J's that are attached to the two Sensors on the Top Cover.

### **Replacement**

1. Reconnect the P/J's to the two Sensors that are attached to the MSI Top Cover Assembly.
2. Route the wire harnesses along the channels molded into the underside of the Cover.
3. Reinstall the MSI Harness Plate to the MSI Top Cover making sure the two latches secure the Plate to the Cover.
4. Reinstall the MSI Top Cover Assembly to the MSI Frame and use two screws to secure the Cover to the Frame.
5. Reinstall the MSI Rear Cover (RRP 9.24).
6. Reinstall the MSI Front Cover (RRP 9.23).

## RRP 9.27 MSI Edge Sensor (PL4.2.6)

---

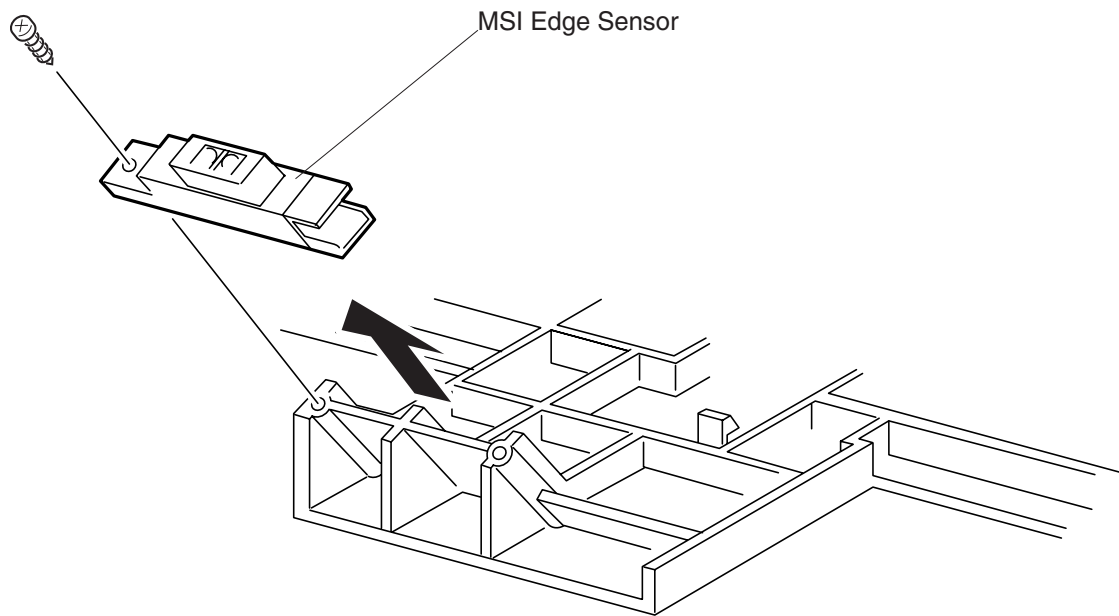

RS1025XB

RS1025XB

## **RRP 9.27 MSI Edge Sensor (PL4.2.6)**

---

### **Removal**

1. Remove the MSI Top Cover Assembly (RRP 9.26).
2. Remove the screw securing the MSI Edge Sensor to the Top Cover and remove the Sensor.

### **Replacement**

1. Reinstall the MSI Edge Sensor onto the MSI Top Cover Assembly, making sure the positioning tab on the bottom of the Sensor fits into the hole in the Top Cover Assembly.
2. Use one screw to secure the MSI Edge Sensor to the MSI Top Cover Assembly.
3. Reinstall the MSI Top Cover Assembly (RRP 9.26).

## RRP 9.28 MSI Short No Paper Sensor (PL4.2.7)

---

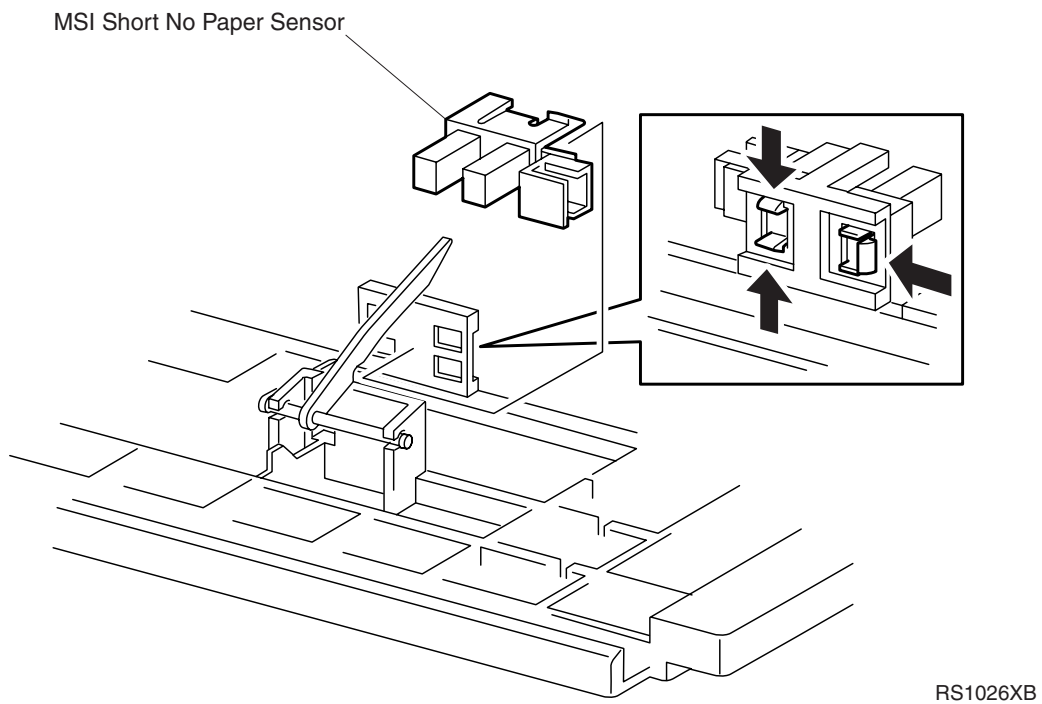

RS1026XB

## **RRP 9.28 MSI Short No Paper Sensor (PL4.2.7)**

---

### **Removal**

1. Remove the MSI Top Cover Assembly (RRP 9.26).
2. Squeeze the latches holding the MSI Short No Paper Sensor to the Top Cover and remove the Sensor.

### **Replacement**

1. Reinstall the MSI Short No Paper Sensor onto the MSI Top Cover Assembly.
2. Press the Sensor latches into the cutouts in the Cover.  
The Sensor snaps into place.
3. Reinstall the MSI Top Cover Assembly (RRP 9.26).

## RRP 9.29 MSI Pick Up Roll (PL4.2.11)

---

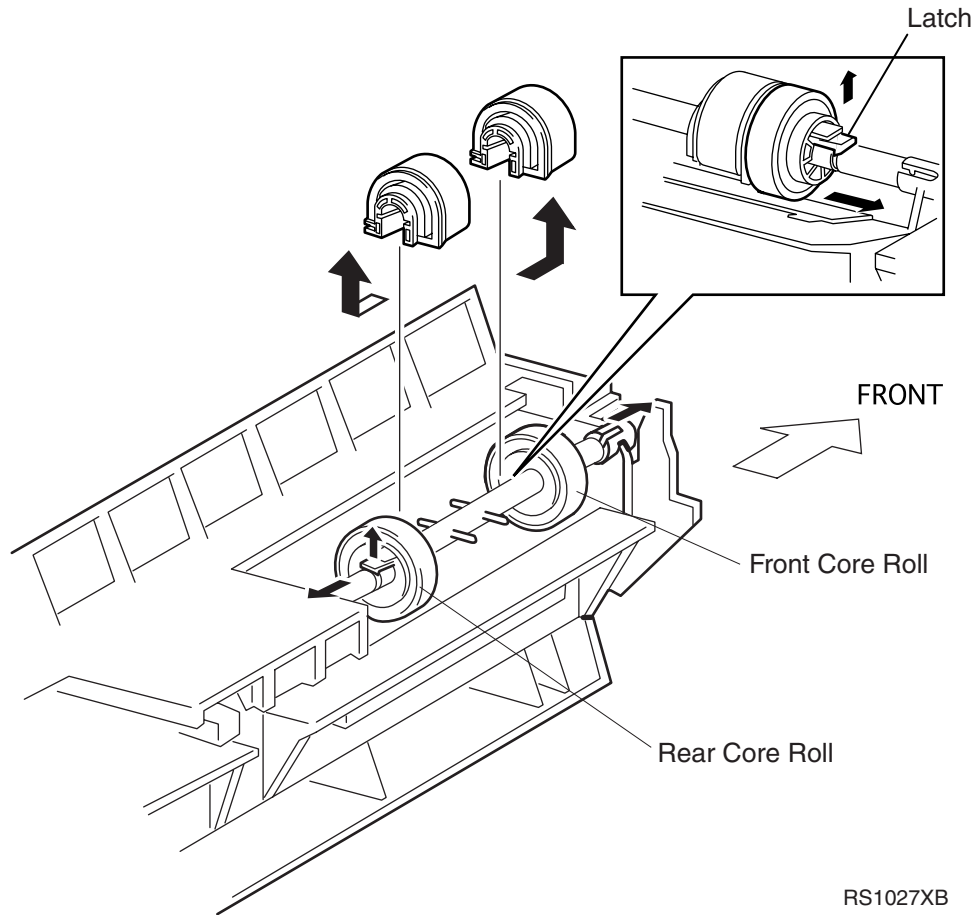

RS1027XB

## RRP 9.29 MSI Pick Up Roll (PL4.2.11)

---

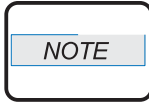

*We recommend that you replace Pick Up Rolls as a set.*

### Removal

1. Remove the MSI Top Cover Assembly (RRP 9.26).
2. Release the latch holding the Front Core Roll to the Pick Up Shaft and slide the Roll away from the Front Pickup Roll.
3. Slide the Front Pick Up Roll toward the Front Core Roll, far enough so the Pick Up Roll clears the locking pin and remove the Front Pick Up Roll.
4. Release the latch holding the Rear Core Roll to the Pick Up Shaft and slide the Roll away from the Rear Pickup Roll.
5. Slide the Rear Pick Up Roll toward the Rear Core Roll, far enough so the Pick Up Roll clears the locking pin and remove the Rear Pick Up Roll.

### Replacement

1. Remove the MSI Top Cover Assembly (RRP 9.26).
2. Release the latch holding the Front Core Roll to the Pick Up Shaft and slide the Roll away from the Front Pickup Roll locking pin.
3. Reinstall the Front Pick Up Roll onto the Pick Up Shaft, making sure the locking pin notch in the Roll matches the position of the locking pin sticking out of the Shaft.
4. Slide the Front Pick Up Roll so the locking pin fits into the notch on the Roll.
5. Slide the Front Core Roll toward the Front Pick Up Roll until the Front Core Roll latch locks into place on the Shaft.
6. Release the latch holding the Rear Core Roll to the Pick Up Shaft and slide the Roll away from the Rear Pickup Roll locking pin.
7. Reinstall the Rear Pick Up Roll onto the Pick Up Shaft, making sure the locking pin notch in the Roll matches the position of the locking pin sticking out of the Shaft.
8. Slide the Rear Pick Up Roll so the locking pin fits into the notch on the Roll.
9. Slide the Rear Core Roll toward the Rear Pick Up Roll until the Rear Core Roll latch locks into place on the Shaft.
10. Reinstall the MSI Top Cover Assembly (RRP 9.26).

## RRP 9.30 MSI Roll Assembly (PL4.2.9)

---

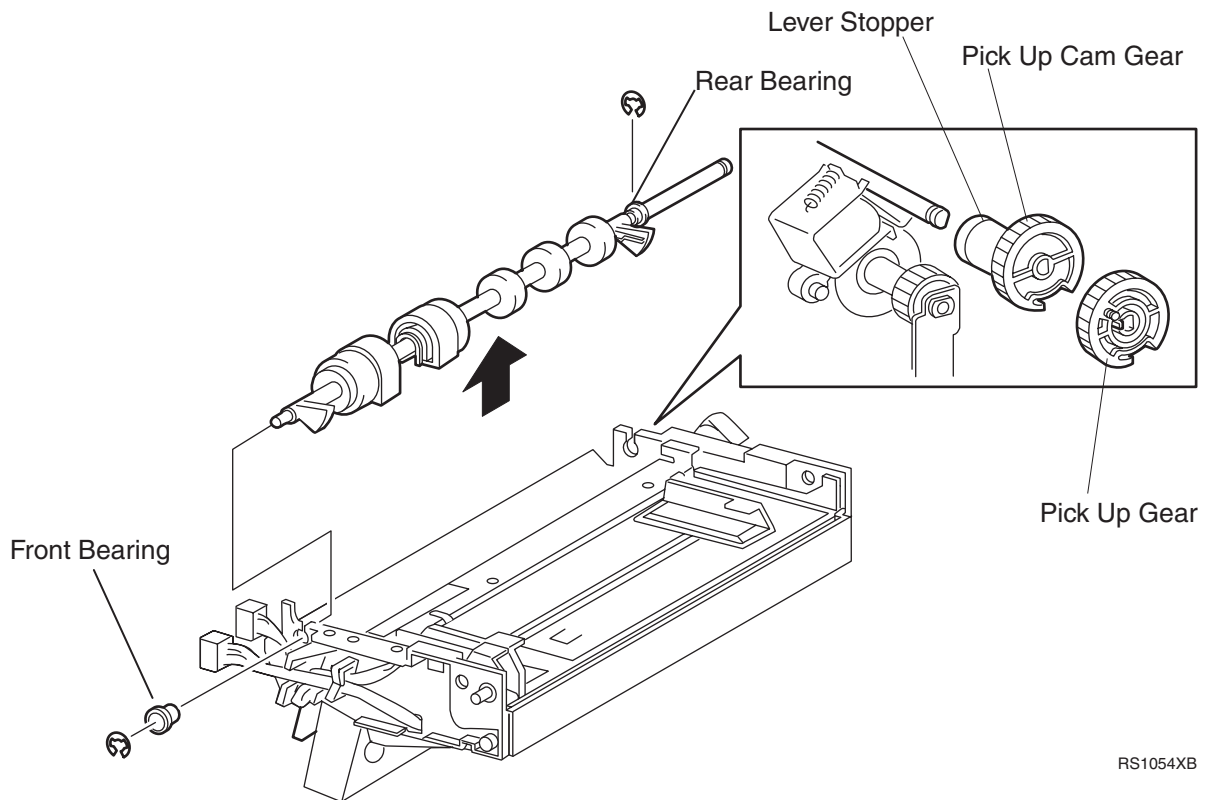

RS1054XB

RS1054XB



## **RRP 9.30 MSI Roll Assembly (PL4.2.9)**

---

### **Removal**

1. Remove the MSI Top Cover Assembly (RRP 9.26).
2. Unhook the Pick Up Spring from the Pick Up Gear.
3. Release the latches holding the Pick Up Gear to the Pick Up Shaft and slide the Pick Up Gear, Pick Up Cam Gear, and Lever Stopper off of the Shaft.
4. Remove the E ring securing the rear shaft bearing to the rear of the MSI.
5. Remove the E ring securing the front shaft bearing to the front of the MSI.
6. Slide the MSI Roll Assembly out of the MSI.

### **Replacement**

1. Reinstall the MSI Roll Assembly by sliding the front and rear of the Shaft into the front and rear cutouts in the MSI.
2. Slide the front shaft bearing into the front bearing cutout and use an E ring to secure the bearing.
3. Slide the rear shaft bearing into the rear bearing cutout and use an E ring to secure the bearing.
4. Push down the arm of the Pick Up Solenoid as you slide the Lever Stopper, Pick Up Cam Gear, and Pick Up Gear onto the Shaft.  
The Pick Up Gear latches lock the Gears in place on the Shaft.
5. Hook the Pick Up Spring onto the Pick Up Gear.
6. Reinstall the MSI Top Cover Assembly (RRP 9.26).

## RRP 9.31 MSI Pick Up Solenoid (PL4.2.21)

---

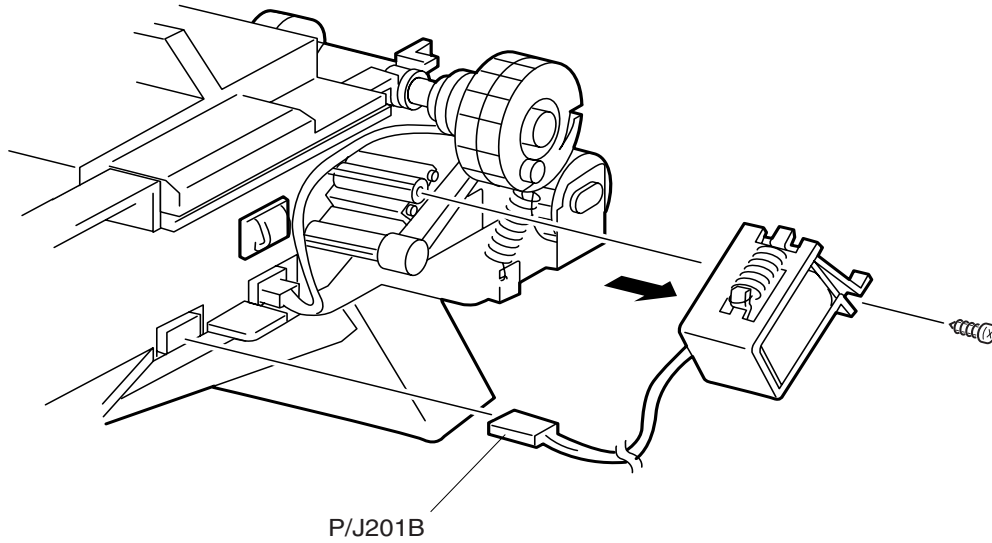

RS1028XB

RS1028XB

## **RRP 9.31 MSI Pick Up Solenoid (PL4.2.21)**

---

### **Removal**

1. Remove the MSI Rear Cover (RRP 9.24).
2. Disconnect P/J 201B.
3. Remove the screw securing the MSI Pick Up Solenoid to the MSI Frame and remove the Solenoid.

### **Replacement**

1. Remove the MSI Rear Cover (RRP 9.24).
2. Hold down the MSI Pick Up Solenoid arm as you reinstall the Solenoid against the MSI frame.
3. Reposition the Solenoid so the two locating pins on the Frame line up with the two holes in the Solenoid.
4. Use one screw to secure the MSI Pick Up Solenoid to the MSI Frame.
5. Reconnect P/J 201B.
6. Reinstall the MSI Rear Cover (RRP 9.24).

## RRP 9.32 MSI Clutch (PL4.2.26)

---

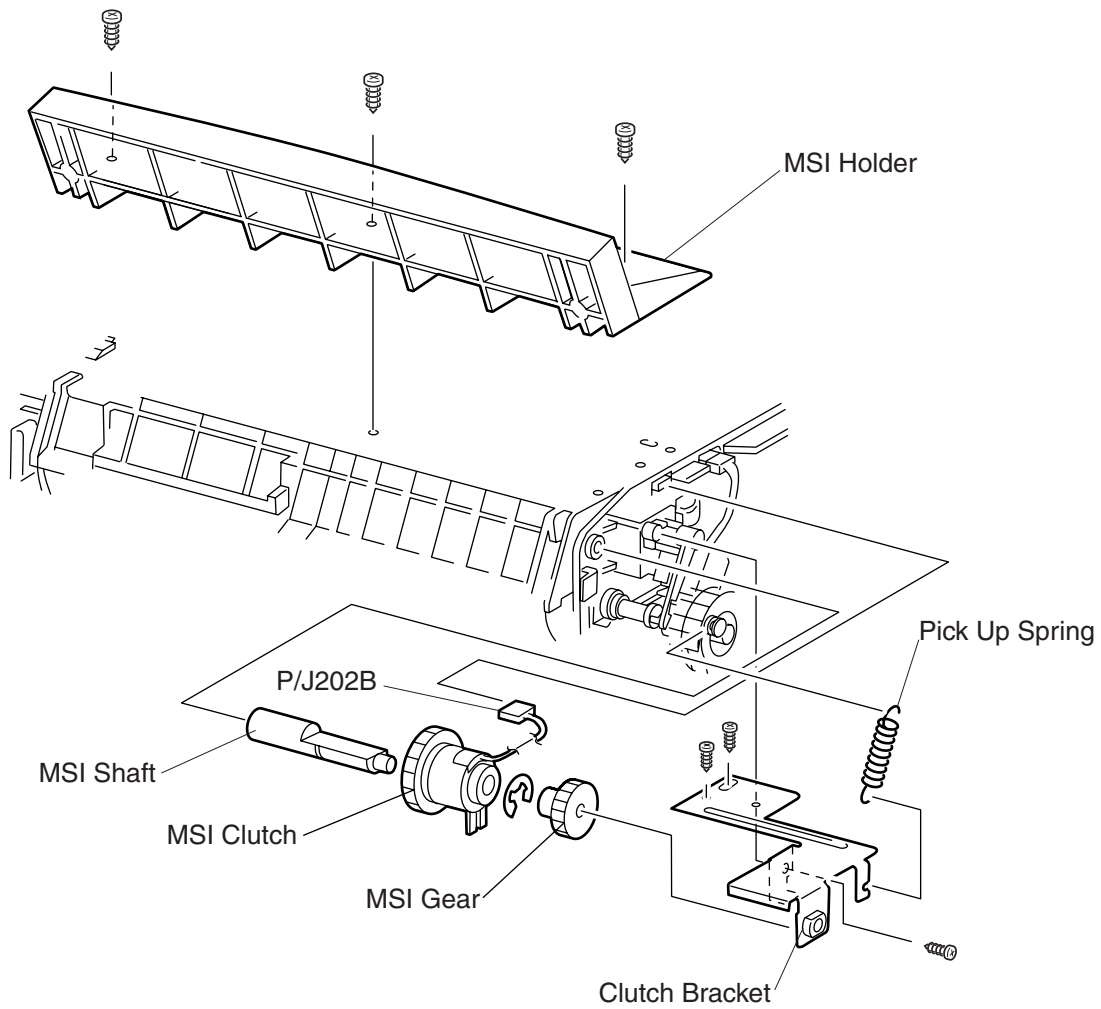

RS1029XC

RS1029XC

## **RRP 9.32 MSI Clutch (PL4.2.26)**

---

### **Removal**

1. Remove the MSI Rear Cover (RRP 9.24).
2. Disconnect P/J 202B.
3. Turn the MSI upside down and remove the three screws securing the MSI Holder to the MSI Frame and remove the Holder.
4. Disconnect the Pick Up Spring from the Clutch Bracket.
5. Remove the two screws securing the Clutch Bracket to the MSI Frame and carefully remove the Bracket.
6. Remove the MSI Gear from the MSI Shaft.
7. Remove the MSI Clutch from the MSI Frame.
8. Slide the MSI Shaft out of the MSI Clutch.

### **Replacement**

1. Position the MSI Shaft so the end with the attached E ring is away from the MSI Clutch.
2. Slide the MSI Shaft through the hole in the MSI Clutch.
3. Position the MSI Clutch so the Clutch gear faces the MSI Frame.
4. Insert the large end of the MSI Shaft into the MSI Rear Bearing.
5. Make sure the MSI Front Bearing is in place in the Clutch Bracket.
6. Carefully reinstall the Clutch Bracket by first making sure the key, the metal tab located next to the screw hole, traps the notch in the Clutch.
7. Insert the free end of the MSI Shaft through the MSI Front Bearing in the Clutch Bracket.
8. Press the Clutch Bracket against the MSI Frame, and reposition the Bracket so the two screw holes line up with the two screw holes in the Frame.
9. Use two screws to secure the Bracket to the Frame.
10. Reconnect the Pick Up Spring to the Clutch Bracket.
11. Reinstall the MSI Holder and use three screws to secure the Holder to the MSI Frame.
12. Reconnect P/J 202B.
13. Reinstall the MSI Rear Cover (RRP 9.24).

## RRP 9.33 MSI Retard Pad Assembly (PL4.3.3)

---

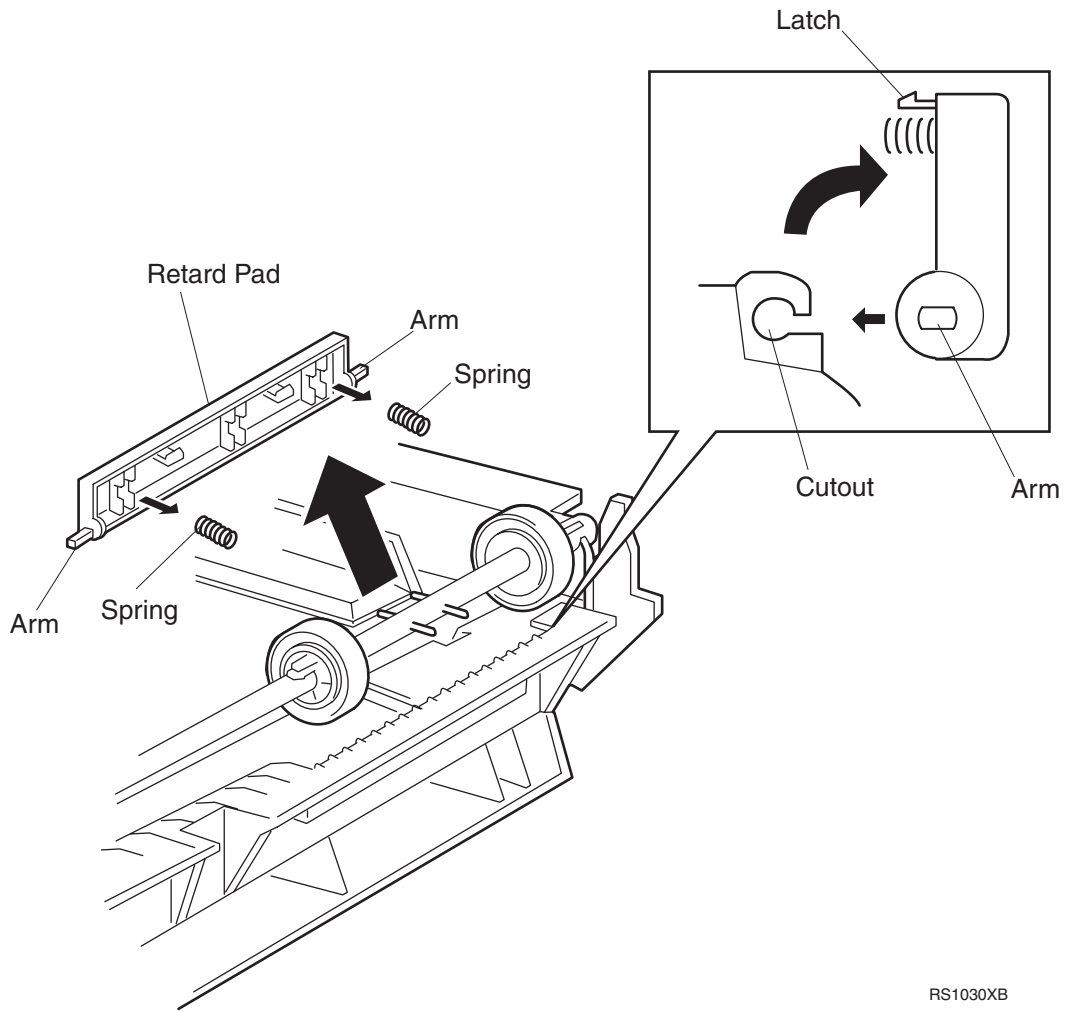

RS1030XB

RS1030XB

## **RRP 9.33 MSI Retard Pad Assembly (PL4.3.3)**

---

### **Removal**

1. Remove both MSI Pick Up Rolls (RRP 9.29).
2. Push the MSI Bottom Plate out of the way.
3. Push down and release the two latches securing the MSI Retard Pad Assembly to the MSI Frame and swing the Assembly down and out of the Frame.

### **Replacement**

1. Position the MSI Retard Pad Assembly so the arms are at the bottom and the springs are facing the MSI Frame.
2. Push the MSI Bottom Plate out of the way.
3. Slide the two arms of the MSI Retard Pad Assembly into the two cutouts in the MSI Frame.
4. Push the MSI Retard Pad Assembly against the MSI Frame until the two Retard Pad latches snap into place.
5. Press and release the Retard Pad to make sure it moves smoothly and has a slight spring action return.
6. Reinstall the MSI Pick Up Rolls (RRP 9.29).

## RRP 9.34 MSI Bottom Assembly (PL4.3.9)

---

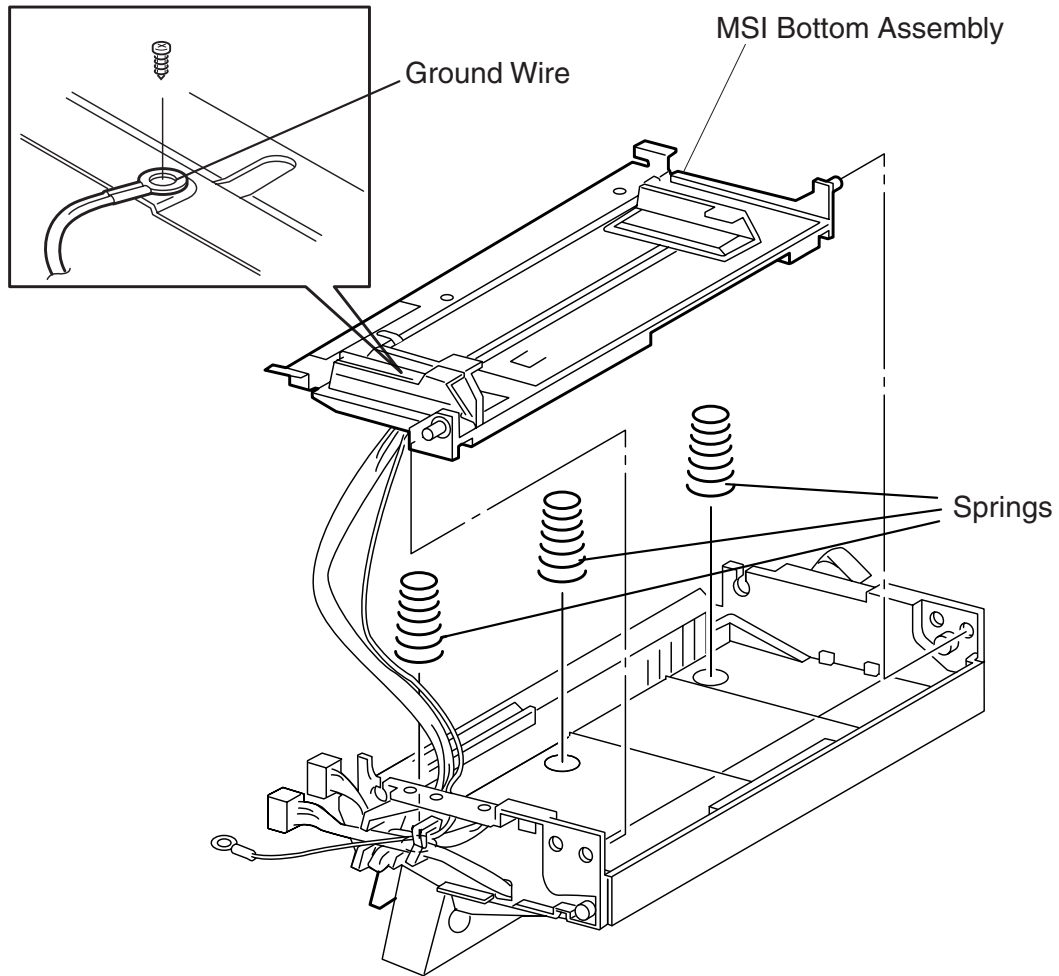

RS1031XB

RS1031XB



## **RRP 9.34 MSI Bottom Assembly (PL4.3.9)**

---

### **Removal**

1. Remove the MSI Top Cover (RRP 9.26).
2. Remove the Pick Up Spring from the Clutch Bracket.
3. Remove the E ring securing the Pick Up Shaft to the Front MSI Bearing.
4. Remove the E ring securing the Pick Up Shaft to the Rear MSI Bearing and remove the Shaft.
5. Carefully pry the rear pivot arm of the MSI Bottom Assembly out of the pivot hole in the MSI Frame.
6. Slide the front pivot arm of the MSI Bottom Assembly out of the pivot hole in the MSI Frame and remove the MSI Bottom Assembly.
7. If installed, remove the screw securing the ground wire to the Bottom Assembly and remove the wire.
8. Disconnect the P/J's from the two sensors that are attached to the bottom of the MSI Bottom Assembly.

### **Replacement**

1. Reconnect the two P/J's to the two sensors that are attached to the bottom of the MSI Bottom Assembly.
2. If installed, reinstall the ground wire to the Bottom Assembly and use one screw to secure the wire.
3. Position the MSI Bottom Assembly on top of the MSI Frame.
4. Slide the front pivot arm of the MSI Bottom Assembly into the pivot hole in the MSI Frame.
5. Pull back on the rear pivot arm of the MSI Bottom Assembly and slide the rear pivot arm into the pivot hole in the MSI Frame.
6. Once the MSI Bottom Assembly is secured in place, lift the Assembly and reinstall the three MSI Springs.
7. Push the Retard Pad out of the way and then press and release the MSI Bottom Assembly to make sure the Springs are in place and provide the Assembly with a strong spring return.
8. Push the Pick Up Solenoid arm down and out of the way while you reinstall the Pick Up Shaft into the notches in the MSI Frame.
9. Slide the Front MSI Bearing and the Rear MSI Bearing into the notches and use an E ring to secure each end of the Shaft to the bearings.
10. Reconnect the Pick Up Spring to the Clutch Bracket.
11. Reinstall the MSI Top Cover (RRP 9.26).

## RRP 9.35 MSI Long No Paper Sensor (PL4.3.16)

---

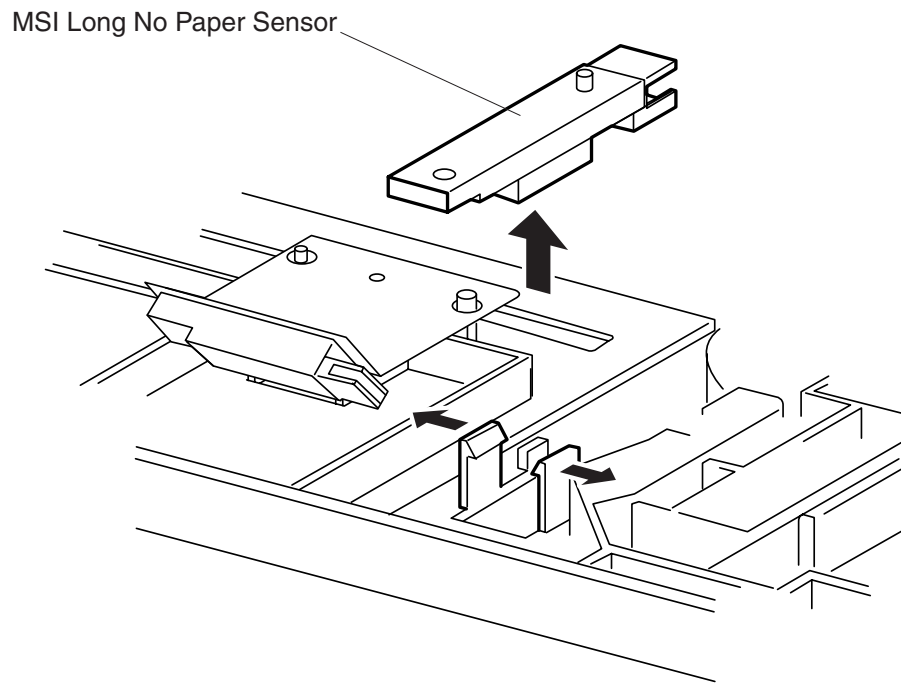

RS1032XB

RS1032XB

## **RRP 9.35 MSI Long No Paper Sensor (PL4.3.16)**

---

### **Removal**

1. Remove the MSI Bottom Assembly (RRP 9.34).
2. Spread the latches securing the MSI Long No Paper Sensor to the MSI Bottom Assembly, and remove the Sensor.

### **Replacement**

1. Position the MSI Long No Paper Sensor onto the MSI Bottom Assembly so the position tab on the Assembly fits through the positioning hole at the end of the Sensor.
2. Spread the latches and press the Sensor onto the MSI Bottom Assembly.  
The latches lock the Sensor into place.
3. Reinstall the MSI Bottom Assembly (RRP 9.34).

## RRP 9.36 Main Paper Handling Assembly (PL5.1.1)

---

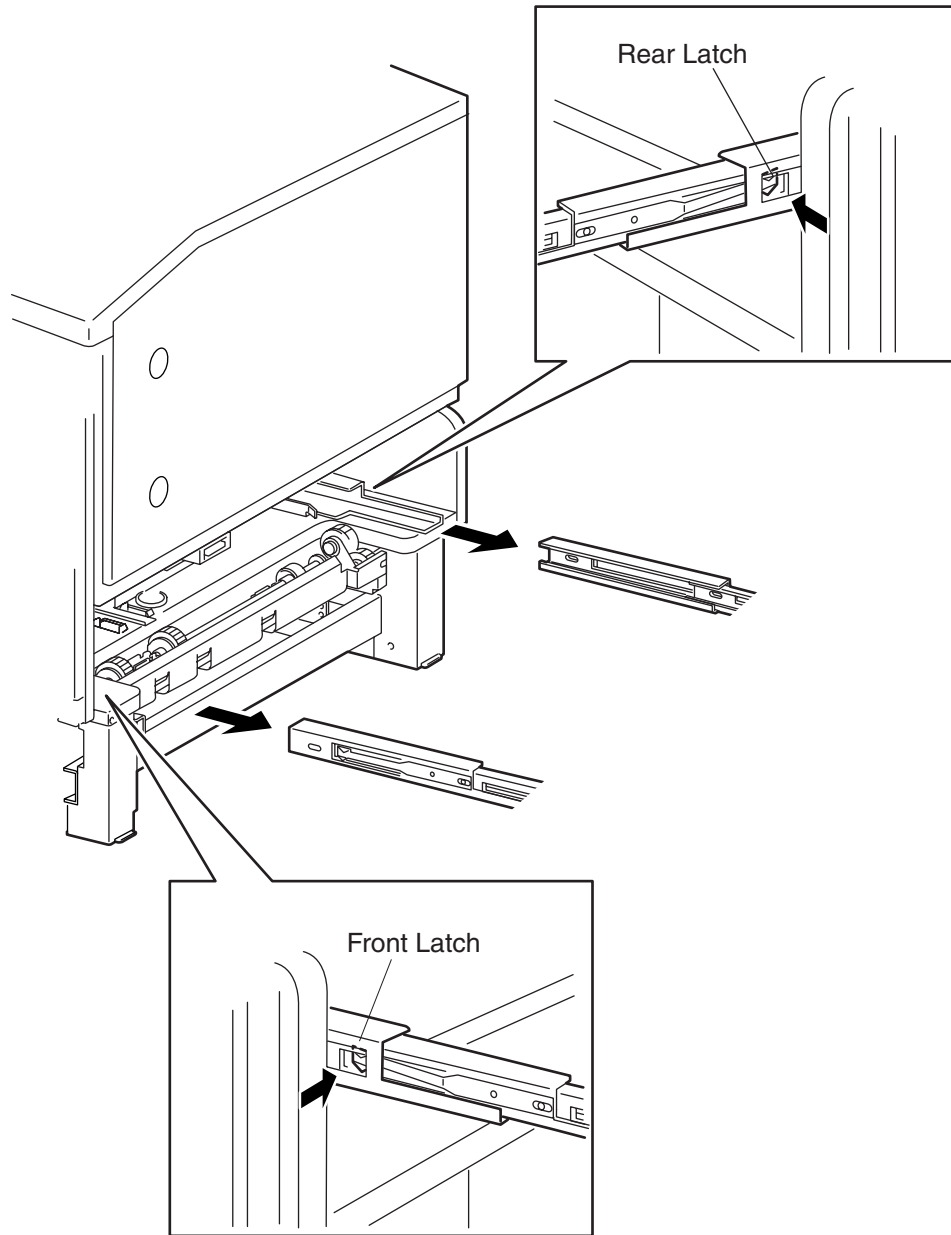

RS1034XB

RS1034XB

## **RRP 9.36 Main Paper Handling Assembly (PL5.1.1)**

---

### **Removal**

1. Remove the MSI Assembly (RRP 9.22).
2. Slide the Main Paper Handling Assembly far enough out of the printer so you can reach the Assembly Rails.
3. Push in on the Front Rail latch as you slide the front of the Assembly out far enough to disengage the latch.
4. Push in on the Rear Rail latch as you slide the rear of the Assembly out far enough to disengage the latch.
5. Slide the Main Paper Handling Assembly out of the printer.

### **Replacement**

1. Position the Main Paper Handling Assembly so the Front and Rear Rails on the Assembly line up with the Front and Rear Rails of the printer frame.
2. Push in on the Rear Rail latch as you slide the rear of the Assembly into the printer far enough so the latch engages.
3. Push in on the Front Rail latch as you slide the rear of the Assembly into the printer far enough so the latch engages.
4. Slide the Main Paper Handling Assembly all the way into the printer and then out again to make sure the Assembly slides smoothly.
5. Reinstall the MSI Assembly (RRP 9.22).

## RRP 9.37 Paper Handling Turn Chute Assembly (PL5.1.4)

---

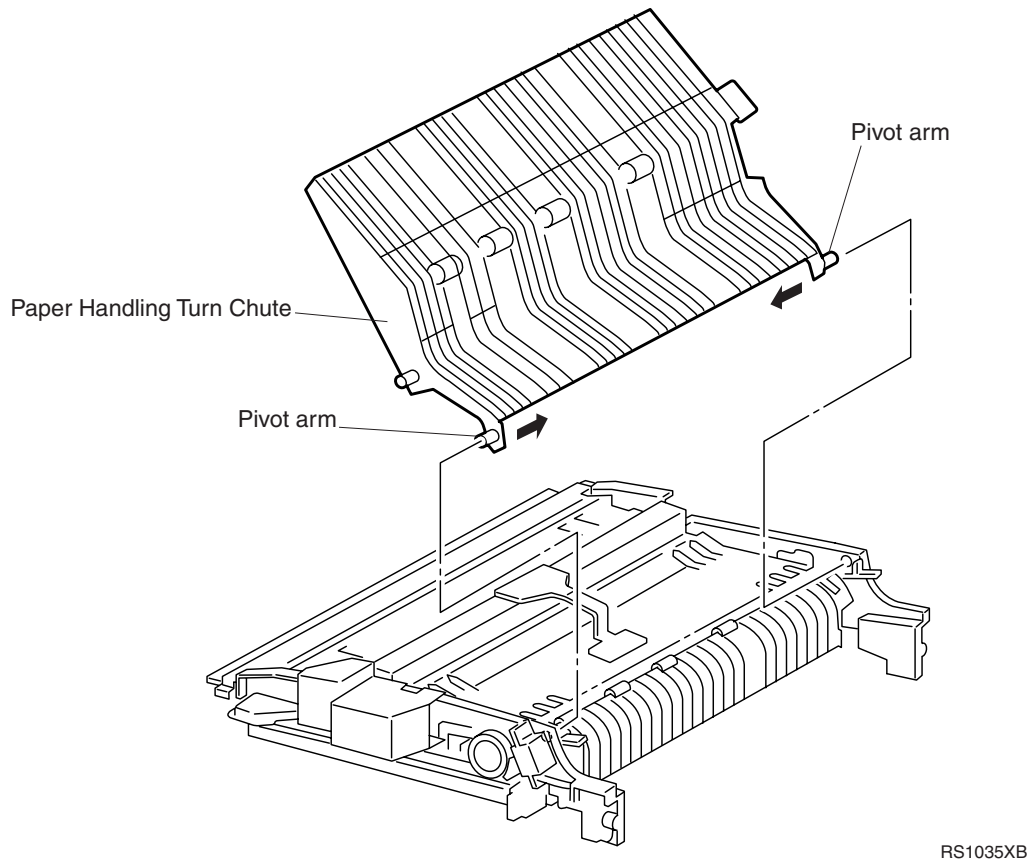

RS1035XB

## **RRP 9.37 Paper Handling Turn Chute Assembly (PL5.1.4)**

---

### **Removal**

1. Remove the MSI Assembly (RRP 9.22).
2. Remove the two screws securing the Main Paper Handling Cover to the Main Paper Handling Assembly and remove the Cover.
3. Remove the Pre-Registration Chute Assembly (RRP 9.38).
4. Pry free the front and rear pivot arms located at the bottom of the Paper Handling Turn Chute Assembly and lift up on the bottom of the Chute Assembly.
5. Pry free the front and rear pivot arms located at the top of the Paper Handling Turn Chute Assembly and remove the Chute Assembly from the Main Paper Handling Assembly.

### **Replacement**

1. Insert the front and rear pivot arms located at the top of the Paper Handling Turn Chute Assembly into the holes at the top of the Main Paper Handling Assembly.
2. Swing the Paper Handling Turn Chute Assembly down into position and insert the front and rear pivot arms located at the bottom of the Paper Handling Turn Chute Assembly into the holes at the bottom of the Main Paper Handling Assembly.
3. Reinstall the Pre-Registration Chute Assembly (RRP 9.38).
4. Reinstall the Main Paper Handling Cover onto the Main Paper Handling Assembly and use two screws to secure the Cover to the Assembly.
5. Reinstall the MSI Assembly (RRP 9.22).

## RRP 9.38 Pre-Registration Chute Assembly (PL5.1.5)

---

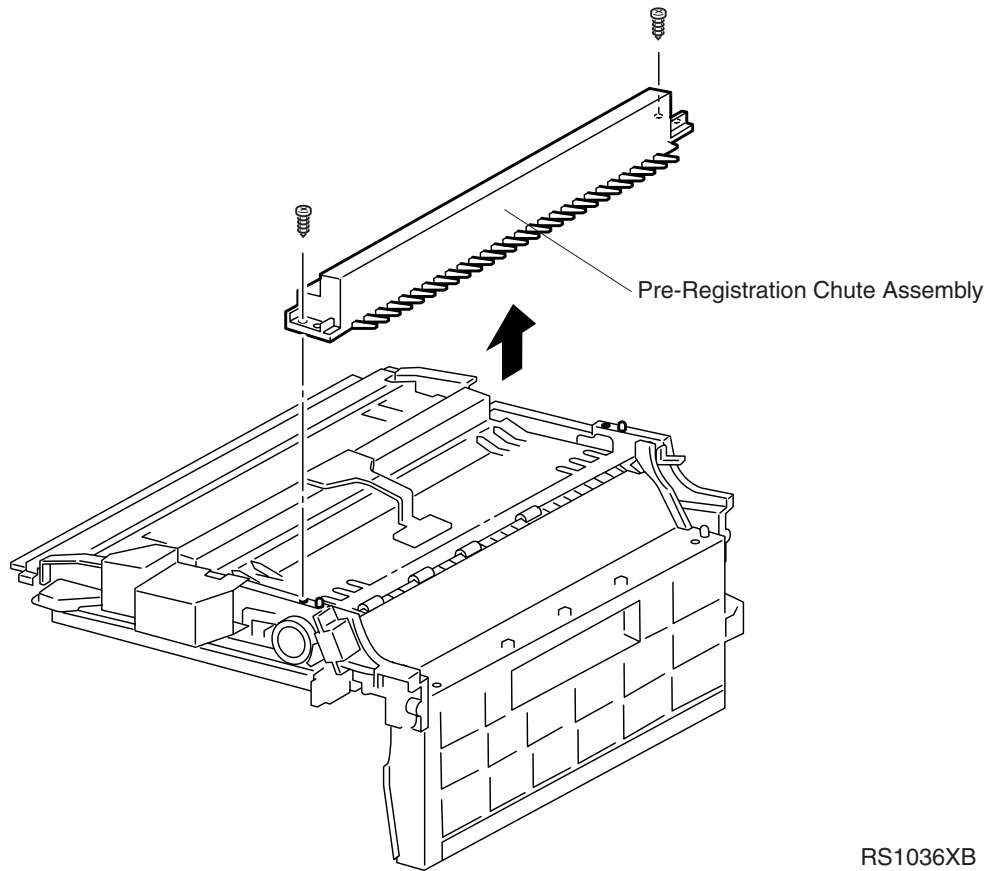

RS1036XB

RS1036XB



## **RRP 9.38 Pre-Registration Chute Assembly (PL5.1.5)**

---

### **Removal**

1. Slide the Main Paper Handling Assembly out of the printer.  
You do not need to remove the Assembly.
2. Remove the two screws securing the Pre-Registration Chute Assembly to the Main Paper Handling Assembly and remove the Chute Assembly.

### **Replacement**

1. Position the Pre-Registration Chute Assembly with the pinch rolls facing down.
2. Reinstall the Pre-Registration Chute Assembly onto the Main Paper Handling Assembly, making sure you line up the two positioning holes in the Chute Assembly with the two positioning tabs on the Main Paper Handling Assembly.
3. Use two screws to secure the Pre-Registration Chute Assembly to the Main Paper Handling Assembly.
4. Close the Main Paper Handling Assembly.

## RRP 9.39 Registration Chute Assembly (PL5.1.6)

---

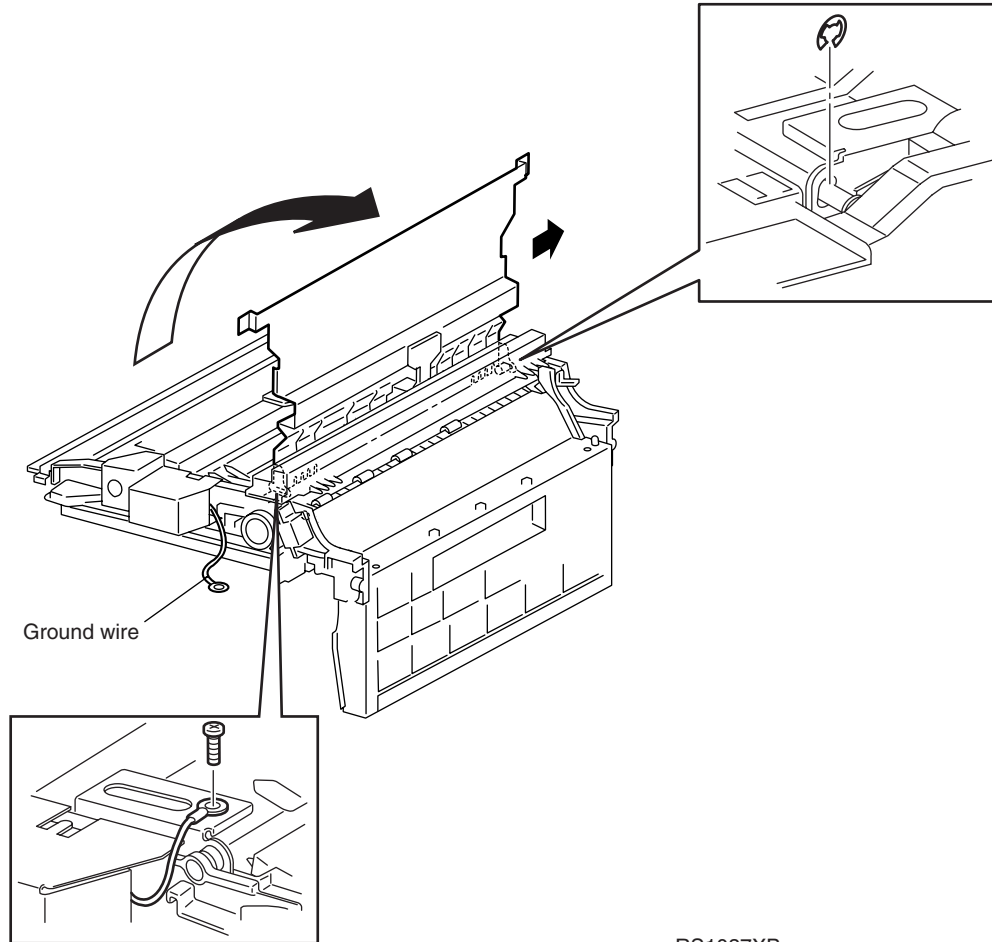

RS1037XB

RS1037XB

## **RRP 9.39 Registration Chute Assembly (PL5.1.6)**

---

### **Removal**

1. Slide the Main Paper Handling Assembly out of the printer.  
You do not need to remove the Assembly.
2. Remove the E ring securing the rear arm of the Registration Chute Assembly to the Main Paper Handling Assembly.
3. Remove the screw securing the ground wire to the Assembly and remove the wire.
4. Open the Registration Chute Assembly.
5. Slide the Chute Assembly to the rear and remove the Assembly.

### **Replacement**

1. Slide the Main Paper Handling Assembly out of the printer.
2. Slide the rear arm of the Registration Chute Assembly onto the metal pivot that is located at the rear of the Main Paper Handling Assembly.
3. Slide the rear arm far enough onto the rear arm so you can slide the front arm onto the front metal pivot.
4. Slide the Registration Chute Assembly forward so the E ring channel on the rear pivot is behind the rear arm.
5. Use an E ring to secure the rear arm of the Registration Chute Assembly to the Main Paper Handling Assembly.
6. Reinstall the ground wire to the Assembly and use one screw to secure the wire.
7. Close the Main Paper Handling Assembly.

## RRP 9.40 Pre-Registration Roll Assembly (PL5.2.4)

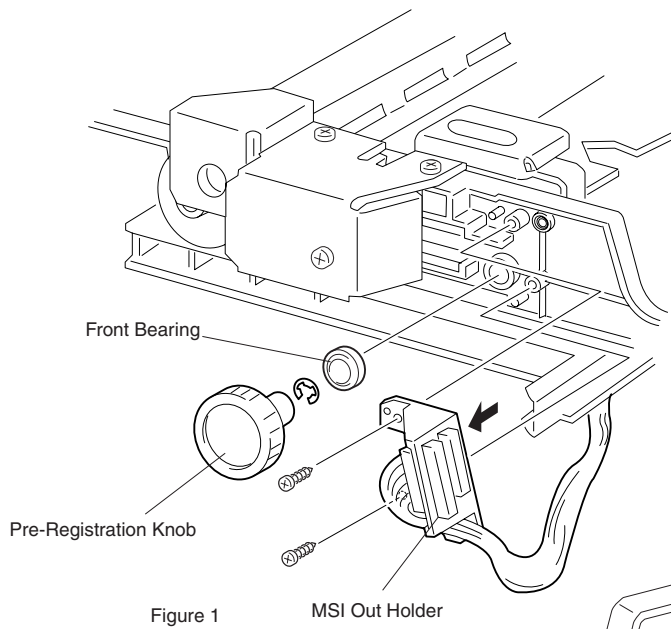

Figure 1

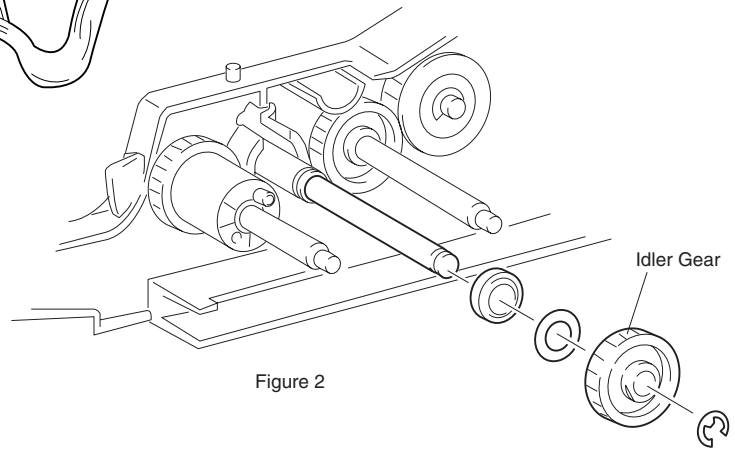

Figure 2

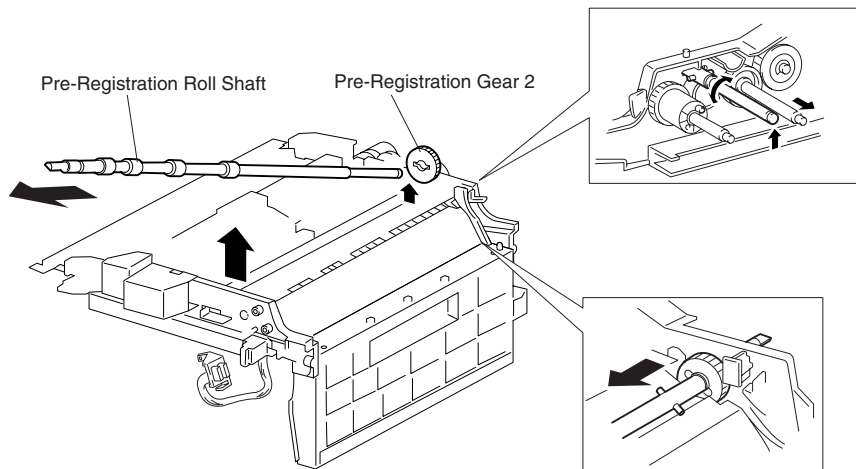

Figure 3

RS1038XB

## **RRP 9.40 Pre-Registration Roll Assembly (PL5.2.4)**

---

### **Removal**

1. Remove the Pre-Registration Clutch (RRP 9.41).
2. Slide the green Pre-Registration Knob off of the Pre-Registration Shaft (Figure 1).
3. Remove two screws securing the MSI Out Holder to the Main Paper Handling Assembly and pull the Holder away from the Assembly.
4. Remove the E ring securing the front of the Pre-Registration Shaft to the Main Paper Handling Assembly frame.
5. Remove the E ring securing the Idler Gear to the rear of the Pre-Registration Shaft and remove the Idler Gear (Figure 2).
6. Slide the Pre-Registration Roll Assembly to the rear of the Main Paper Handling Assembly, freeing the front of the Shaft from front of the Main Paper Handling Assembly.
7. Slide the Pre-Registration Roll Assembly to the front, free the rear of the Shaft from the rear of the Main Paper Handling Assembly.
8. Slide the Pre-Registration Roll Assembly free of Pre-Registration Gear 2 and remove the Shaft (Figure 3).

### **Replacement**

1. Reinstall Pre-Registration Gear 2 into the notch that is located at the rear of the Pre-Registration Roll Assembly channel in the Main Paper Handling Assembly.
2. Slide the rear of the Pre-Registration Roll Assembly through Gear 2 and into the rear hole of the Main Paper Handling Assembly
3. Slide the Shaft far enough so you can slide the front of the Shaft into the front hole of the Main Paper Handling Assembly.
4. Seat the Pre-Registration Roll Assembly into the channel in the Main Paper Handling Assembly, making sure the pin near the end of the shaft captures Gear 2.
5. If necessary, reinstall the bearings to the front and rear of the Pre-Registration Shaft.
6. Reinstall the MSI Out Holder to the Main Paper Handling Assembly and use two screws to secure the Holder.
7. Reinstall the Idler Gear to the rear of the Pre-Registration Shaft and use an E ring to secure the Gear to the Shaft.
8. Use an E ring to secure the front of the Pre-Registration Shaft to the front of the Main Paper Handling Assembly.
9. Reinstall the green Pre-Registration Knob onto the Pre-Registration Shaft.
10. Reinstall the Pre-Registration Clutch (RRP 9.41).

## RRP 9.41 Pre-Registration Clutch (PL5.2.8)

---

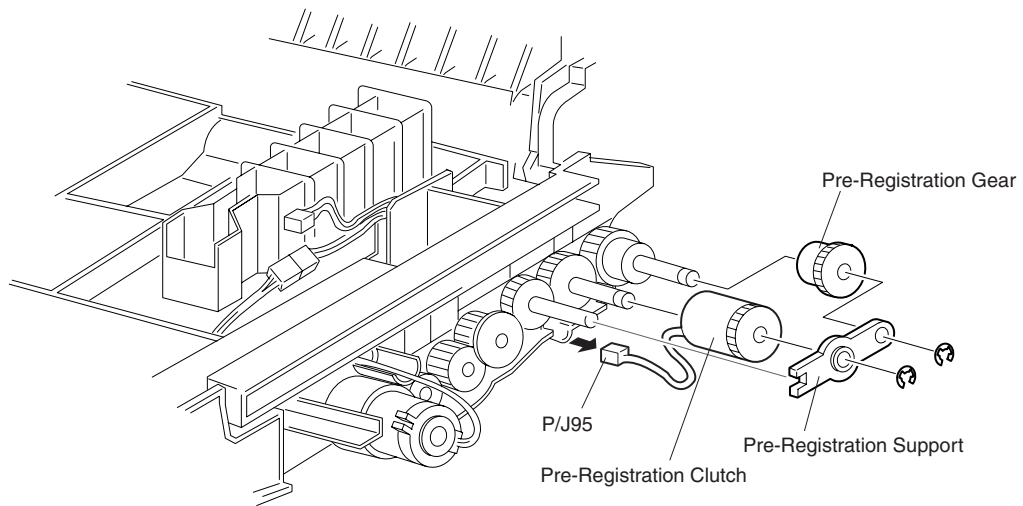

Figure 1

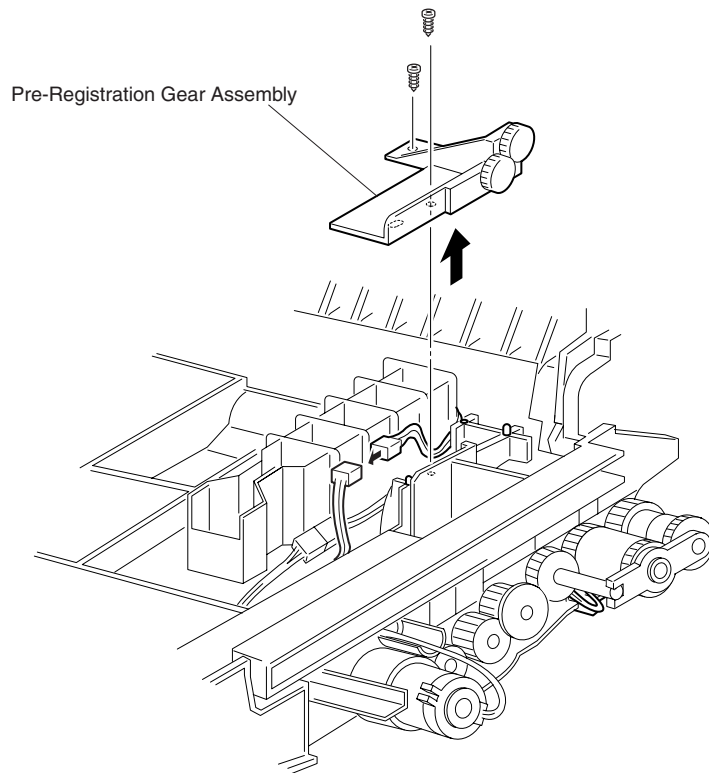

Figure 2

RS1039XB

## **RRP 9.41 Pre-Registration Clutch (PL5.2.8)**

---

### **Removal**

1. Remove the Main Paper Handling Assembly (RRP 9.36).
2. Remove the Pre-Registration Chute Assembly (RRP 9.38).
3. Turn the Main Paper Handling Assembly over and disconnect P/J 95 from the Pre-Registration Clutch.
4. Remove the two screws securing the Pre-Registration Gear Assembly to the Main Paper Handling Assembly and remove the Gear Assembly (Figure 2).
5. Remove the E rings securing the Pre-Registration Clutch and the Pre-Registration Gear to the Pre-Registration Support and remove the Support (Figure 1).
6. Slide the Pre-Registration Gear off of the Shaft.
7. Slide the Pre-Registration Clutch off of the Pre-Registration Shaft.

### **Replacement**

1. Slide the Pre-Registration Clutch onto the Shaft, making sure you slide the key of the Clutch into the tab on the Main Paper Handling Assembly.
2. Slide the Pre-Registration Gear onto the Shaft.
3. Reinstall the Registration Support, making sure you install the open end of the Support onto the Gear 12 shaft.
4. Use E rings to secure the Pre-Registration Clutch and the Pre-Registration Gear to the Pre-Registration Support.
5. Reconnect P/J 95 and route the wire away from any gears.
6. Reinstall the Pre-Registration Gear Assembly to the Main Paper Handling Assembly and use two screws to secure the Gear Assembly.
7. Reinstall the Pre-Registration Chute Assembly (RRP 9.38).
8. Reinstall the Main Paper Handling Assembly (RRP 9.36).

## RRP 9.42 Registration Clutch (PL5.2.15)

---

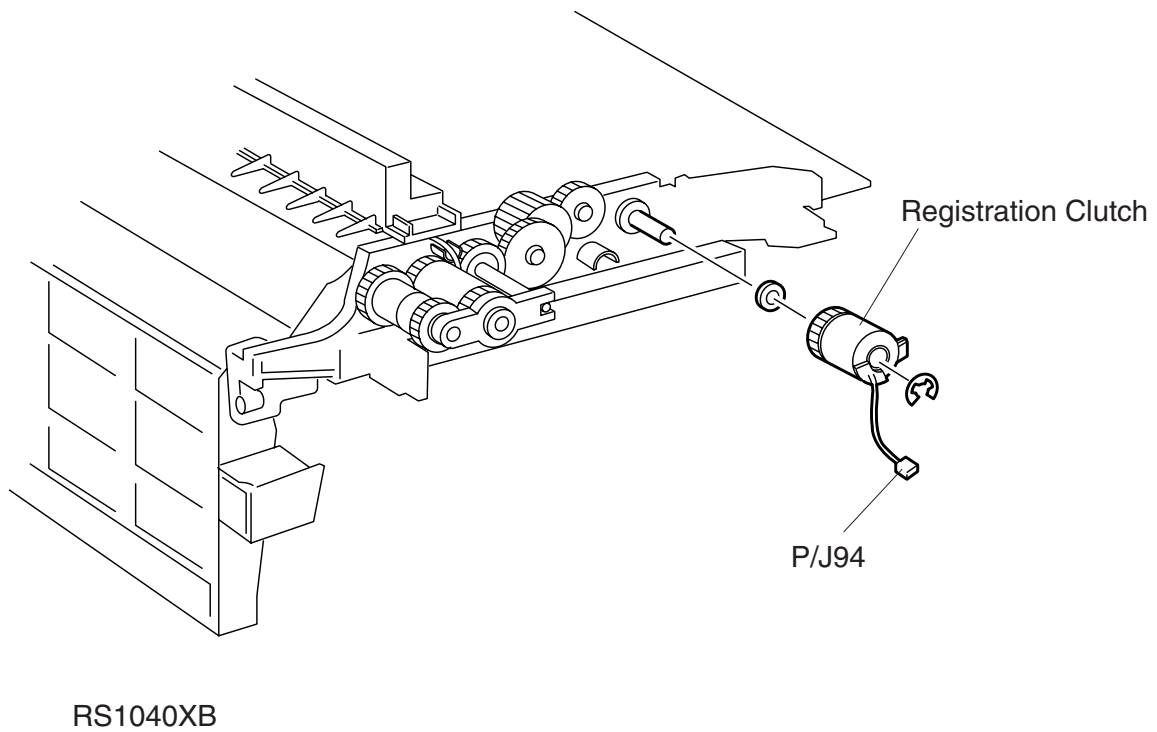

RS1040XB



## **RRP 9.42 Registration Clutch (PL5.2.15)**

---

### **Removal**

1. Remove the Main Paper Handling Assembly (RRP 9.36).
2. Turn the Main Paper Handling Assembly over and disconnect P/J 94 from the Registration Clutch.
3. Open the Registration Chute Assembly.
4. Remove the E ring securing the Registration Clutch to the rear of the Metal Registration Roll and remove the Registration Clutch from the Roll.

### **Replacement**

1. Slide the Registration Clutch onto the end of the Metal Registration Roll making sure you slide the key of the Clutch into the tab on the Main Paper Handling Assembly.
2. Use an E ring to secure the Registration Clutch to the Metal Registration Roll.
3. Route the Registration Clutch wire to the underside of the Main Paper Handling Assembly and reconnect P/J 94.
4. Reinstall the Main Paper Handling Assembly (RRP 9.36).

## RRP 9.43 Metal Registration Roll (PL5.2.16)

---

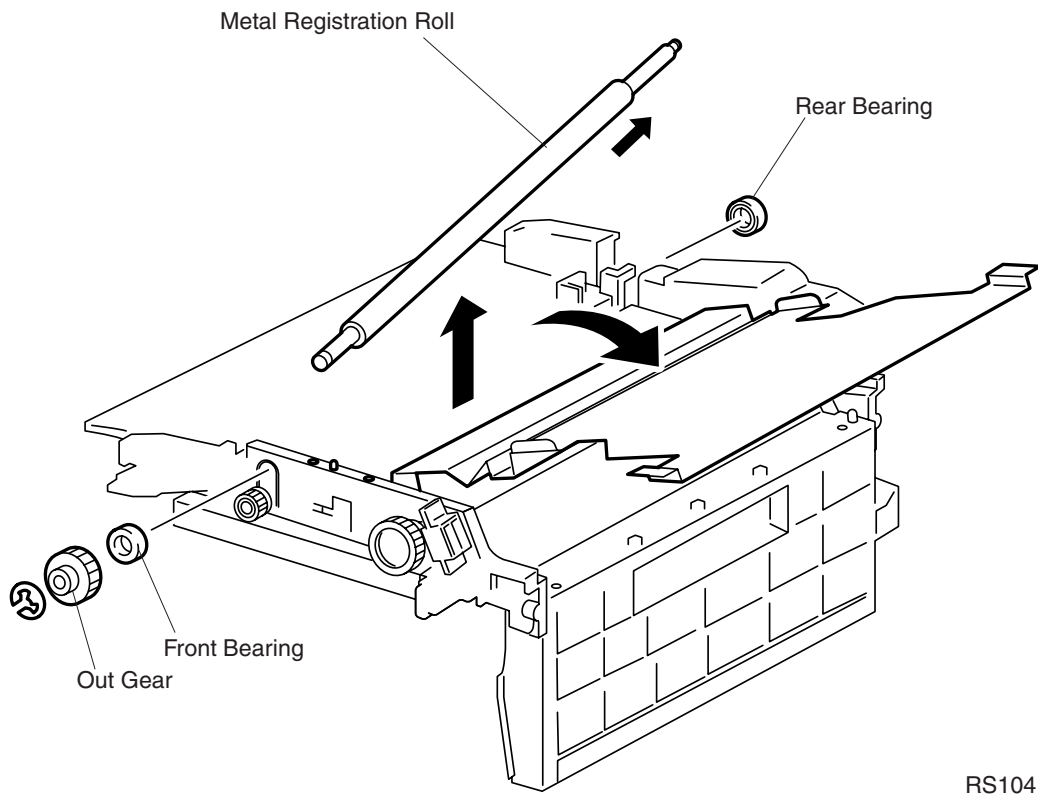

RS1041XB

RS1041XB

## **RRP 9.43 Metal Registration Roll (PL5.2.16)**

---

### **Removal**

1. Remove the Registration Clutch (RRP 9.42).
2. Remove the Registration Brake Clutch (RRP 9.46).
3. Remove the E ring securing the Out Gear at front end of the Metal Registration Roll and remove the Gear.
4. Remove the rear bearing from the Metal Registration Roll.
5. Slide Metal Registration Roll to the rear, slide the front of the Roll out of the front bearing, and remove the Roll from the Main Paper Handling Assembly.

### **Replacement**

1. Insert the front end of the Metal Registration Roll into the front bearing.
2. Snap the rear of the Metal Registration Roll into the rear bearing notch in the Main Paper Handling Assembly.
3. Slip the rear bearing over the rear end of the Metal Registration Roll and slide the bearing in place in the Main Paper Handling Assembly.
4. Slide the Out Gear onto the front of the Metal Registration Roll and push it against the Main Paper Handling Assembly.
5. Use an E ring to secure the Gear onto the end of the Metal Registration Roll.
6. Reinstall the Registration Brake Clutch (RRP 9.46).
7. Reinstall the Registration Clutch (RRP 9.42).

## RRP 9.44 Rubber Registration Roll (PL5.2.24)

---

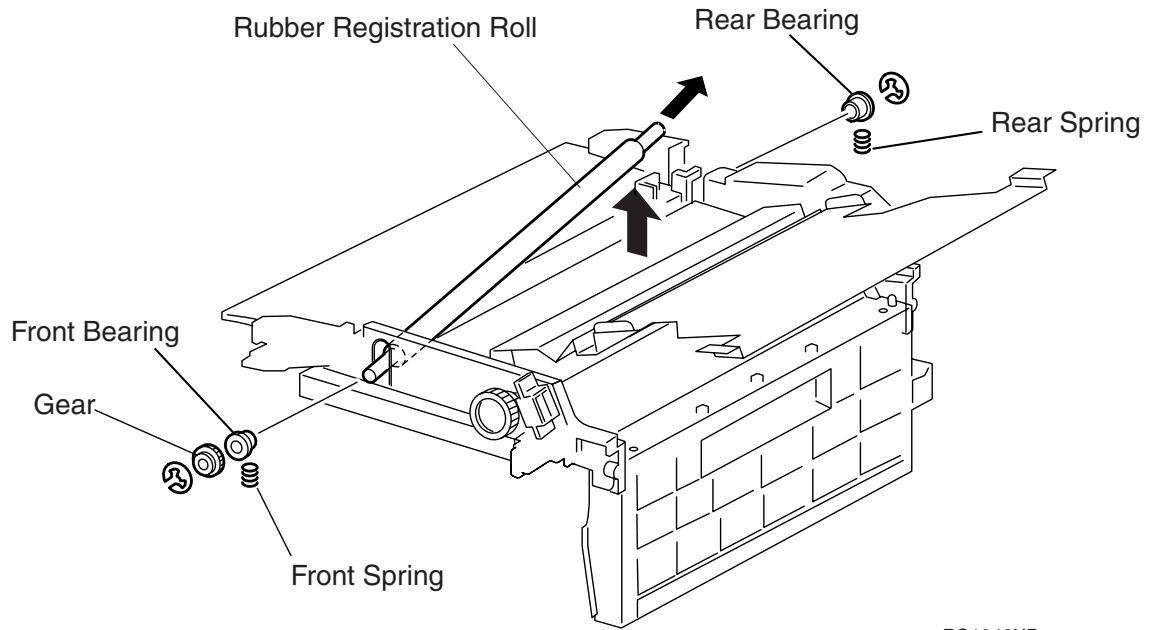

RS1042XB

RS1042XB

## **RRP 9.44 Rubber Registration Roll (PL5.2.24)**

---

### **Removal**

1. Remove the Metal Registration Roll (RRP 9.43).
2. Remove the E ring at the front of the Rubber Registration Roll securing the Gear to the Roll and remove the Gear.
3. Remove the E ring securing the rear of the Rubber Registration Roll to the Main Paper Handling Assembly.
4. Remove the rear bearing and Spring from the end of the Rubber Registration Roll.
5. Slide the Rubber Registration Roll out of the Main Paper Handling Assembly.

### **Replacement**

1. Slide the front end of the Rubber Registration Roll into the front bearing in the Main Paper Handling Assembly.
2. Hold the mylar strip out of the way as you insert the Rubber Registration Roll into the channel in the Main Paper Handling Assembly.
3. Make sure the mylar strip rests on top of the Rubber Registration Roll.
4. Reinstall the rear bearing and Spring, facing down, onto the rear of the Roll.
5. Use an E ring to secure the rear of the Roll to the rear bearing.
6. Reinstall the Gear onto the front end of the Rubber Registration Roll and use an E ring to secure the Gear to the Roll.
7. Reinstall the Metal Registration Roll (RRP 9.43).

## RRP 9.45 Registration Sensor (PL5.2.28)

---

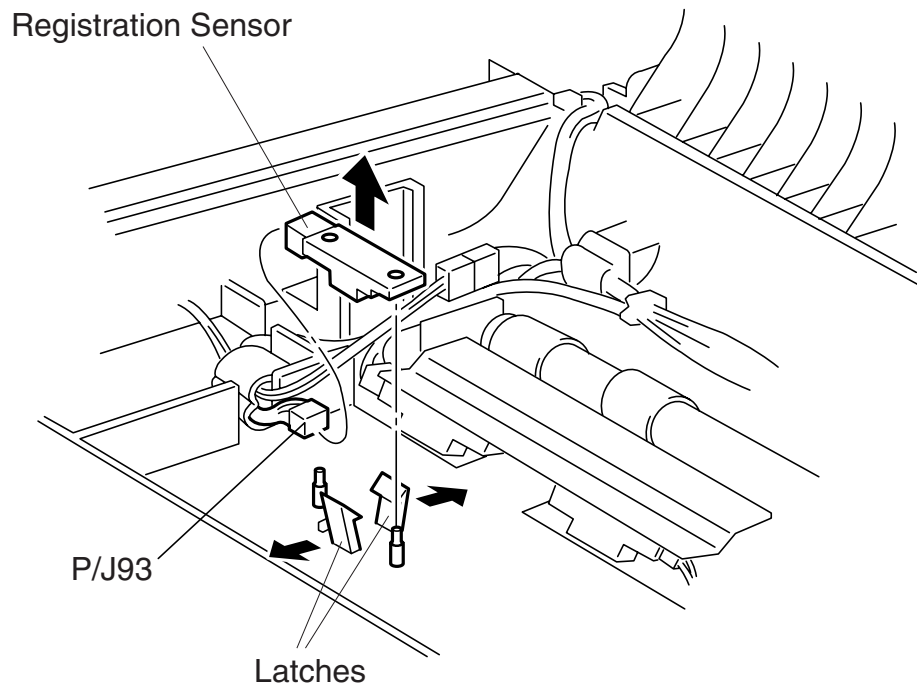

RS1043XB

RS1043XB

## **RRP 9.45 Registration Sensor (PL5.2.28)**

---

### **Removal**

1. Remove the Main Paper Handling Assembly (RRP 9.36).
2. Turn the Main Paper Handling Assembly over and disconnect P/J 93 from the Registration Sensor.
3. Carefully spread the Sensor latch arms as you lift the Sensor away from the latch and off of the Main Paper Handling Assembly.

### **Replacement**

1. Align the Registration Sensor so the LEDs are against the Main Paper Handling Assembly and the positioning hole at the end of the Sensor is over the positioning tab on the Assembly.
2. Carefully press the Registration Sensor into position on the Main Paper Handling Assembly. The latch arms lock the Sensor into place.
3. Reconnect P/J 93 to the Registration Sensor.
4. Reinstall the Main Paper Handling Assembly (RRP 9.36).

## RRP 9.46 Registration Brake Clutch (PL5.2.20)

---

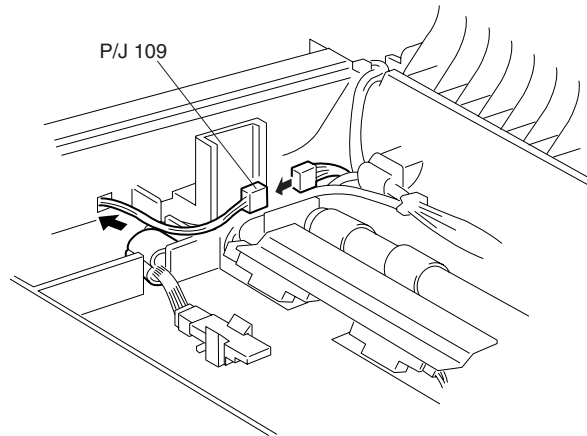

Figure 1

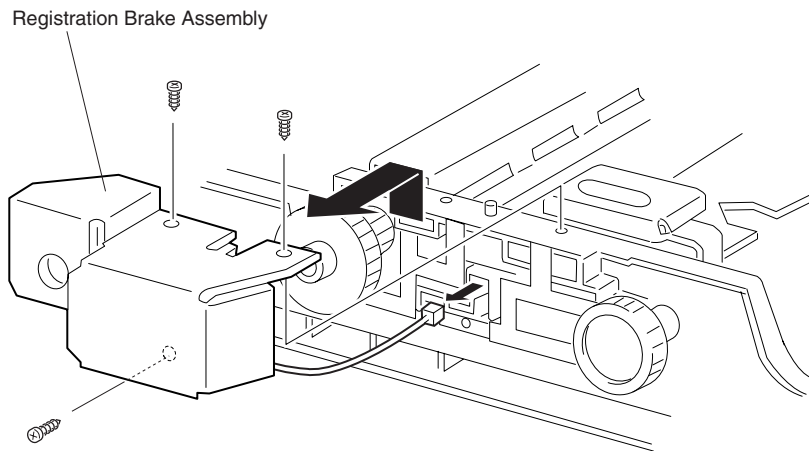

Figure 2

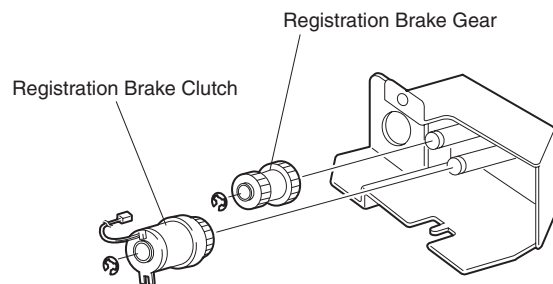

Figure 3

RS1056XB

RS1056XB



## **RRP 9.46 Registration Brake Clutch (PL5.2.20)**

---

### **Removal**

1. Remove the Main Paper Handling Assembly (RRP 9.36).
2. Turn the Main Paper Handling Assembly over and disconnect P/J 109 from the Registration Brake Clutch (Figure 1).
3. Remove the three screws securing the Registration Brake Clutch Assembly to the side of the Main Paper Handling Assembly and remove the Assembly (Figure 2).
4. Remove the E ring securing the Registration Brake Clutch to the Clutch shaft and remove the Clutch (Figure 3).
5. Remove the E ring securing the Registration Brake Gear to the Gear shaft and remove the Gear.

### **Replacement**

1. Reinstall the Registration Brake Gear onto the Gear shaft and use an E ring to secure the Gear (Figure 3).
2. Reinstall the Registration Brake Clutch onto the Clutch shaft and use an E ring to secure the Clutch.
3. Reinstall the Registration Brake Clutch Assembly onto the side of the Main Paper Handling Assembly making sure you thread the Clutch wire harness through the hole in the side of the Paper Handling Assembly.
4. Use three screws to secure the Registration Brake Clutch Assembly to the Main Paper Handling Assembly.
5. Reconnect P/J 109 to the Registration Brake Clutch (Figure 1).
6. Reinstall the Main Paper Handling Assembly (RRP 9.36).

## RRP 9.47 ROS Assembly (PL6.1.1)

---

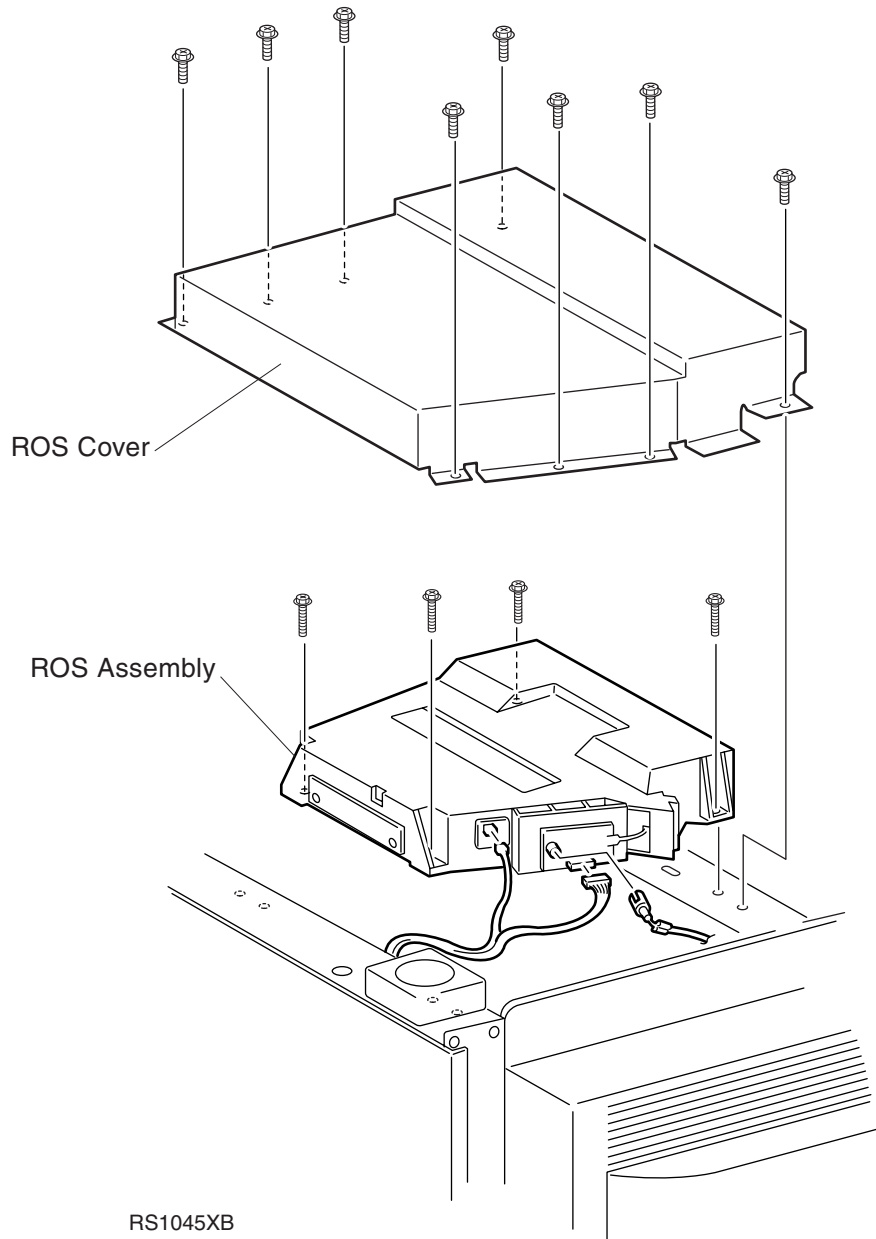

RS1045XB

## **RRP 9.47 ROS Assembly (PL6.1.1)**

---

### **Removal**

1. Remove the Top Cover Assembly (RRP 9.3).
2. Remove the eight screws securing the ROS Cover to the printer frame and remove the Cover.
3. Disconnect P/J 121 and P/J 122 from the Laser Diode PWB.
4. Disconnect P/J 124 from the SOS Sensor PWB.
5. Remove the four screws securing the ROS Assembly to the printer frame.
6. Carefully lift the ROS Assembly a few inches off of the printer frame and reach under the Assembly and disconnect P/J 123 from the ROS Motor PWB.
7. Remove the ROS Assembly.

### **Replacement**

1. Position the ROS Assembly over the printer frame.
2. Reconnect P/J 123 to the ROS Motor PWB located under the Assembly.
3. Lower the ROS Assembly onto the printer frame and line up the four screws holes in the Assembly with the four screw holes in the frame.
4. Use four screws to secure the ROS Assembly to the printer frame.
5. Reconnect P/J 124 to the SOS Sensor PWB.
6. Reconnect P/J 121 and P/J 122 to the Laser Diode PWB.
7. Reinstall the ROS Cover over the ROS Assembly and use eight screws to secure the Cover to the printer frame.
8. Reinstall the Top Cover Assembly (RRP 9.3).

## RRP 9.48 Xerographic Cartridge (PL6.1.11)

---

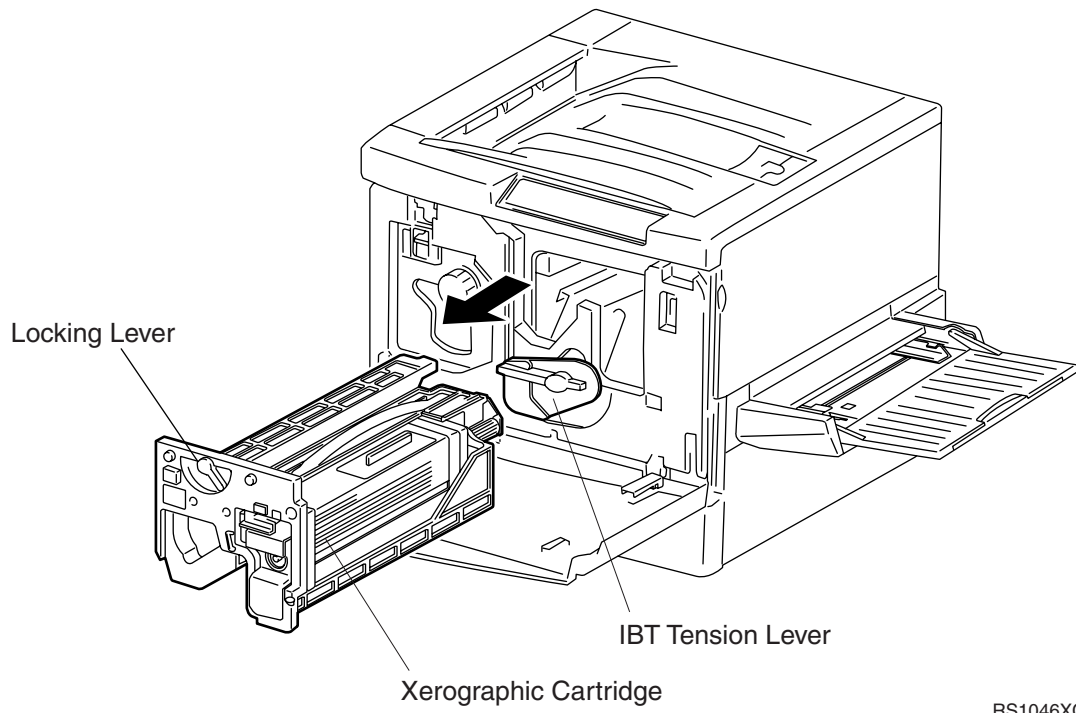

RS1046XC

## RRP 9.48 Xerographic Cartridge (PL6.1.11)

---

### Removal

1. Open the Front Cover.
2. Lower the IBT Tension Lever.
3. Move the Xerographic Cartridge locking lever to the right.
4. Pull the Xerographic Cartridge approximately eight inches out of the print engine.
5. Use one hand to hold onto the Cartridge strap and use the other hand to pull the Cartridge free of the print engine.
6. Place the Xerographic Cartridge in a light-tight bag to protect the Xerographic Drum from light damage.



*The Xerographic Drum, the large blue cylinder, is easily damaged. Use extreme care when removing or storing the Cartridge so it does not get scratched or nicked.*

### Replacement

1. Open the Front Cover.
2. Lower the IBT Tension Lever.
3. Move the Xerographic Cartridge locking lever to the right.
4. Use one hand to hold onto the Cartridge strap and use the other hand to push the Cartridge into the print engine cavity.
5. Line up the rail at the top left of the Cartridge with the rail in the print engine cavity.
6. Keep the Cartridge level as you carefully push the Cartridge into the cavity.
7. When the Cartridge is completely inside the cavity, move the locking lever to the left to lock the Cartridge in place.
8. Pull out on the Cartridge to make sure it is secured in place.
9. Raise the IBT Tension Lever.
10. Close the Front Cover.
11. If your printer configuration does not support the CRUM automatic life counter reset, then refer to Section 9 of this manual and reset the Xerographic Cartridge Life Counter to zero.

## RRP 9.49 Waste Toner Box (PL6.1.12)

---

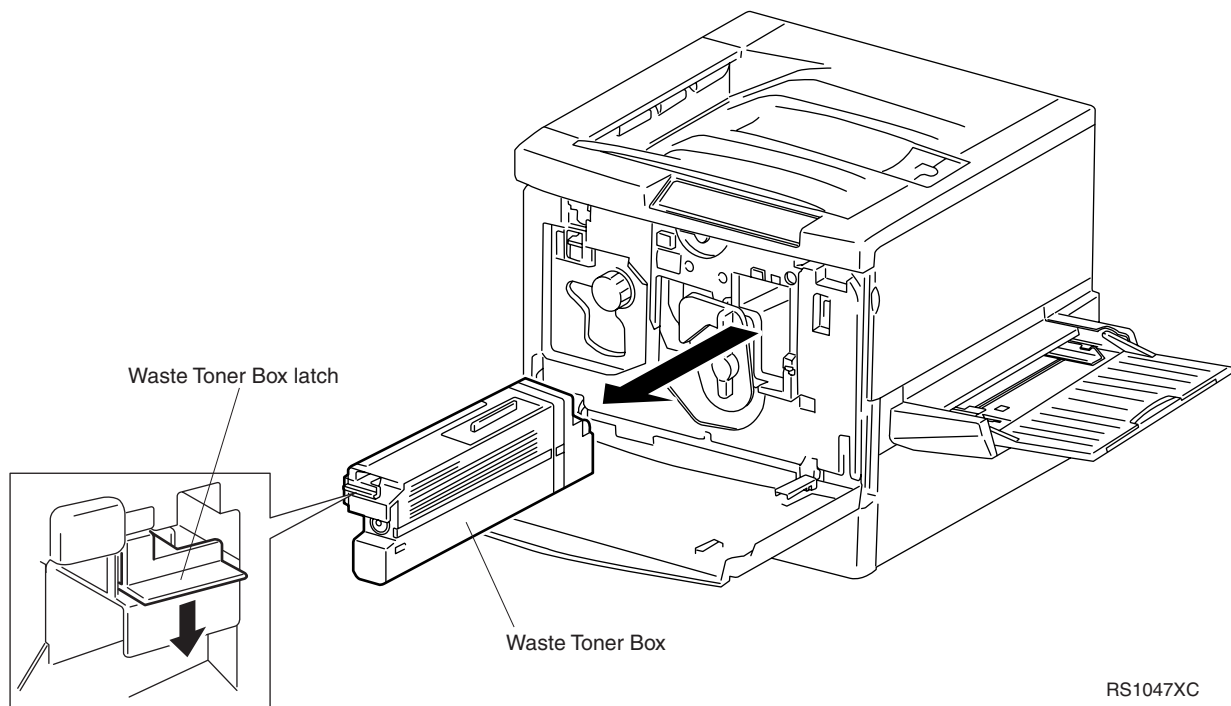

RS1047XC

## RRP 9.49 Waste Toner Box (PL6.1.12)

---

### Removal

1. Open the Front Cover.
2. Lower the IBT Tension Lever.
3. Place your forefinger under the Waste Toner Box lip and push down with your thumb on the Waste Toner Box latch.
4. Pull the Waste Toner Box straight out and remove it from the print engine.



*Keep the Waste Toner Box level. The Box contains toner. Do not turn the Box upside down.*

### Replacement

1. Open the Front Cover.
2. Slide the Waste Toner Box into the Toner Box cavity.
3. Push in on the Waste Toner Box until it latches into place.
4. Raise the IBT Tension Lever.
5. Close the Front Cover.

## RRP 9.50 ADC Sensor Assembly (PL6.1.20)

---

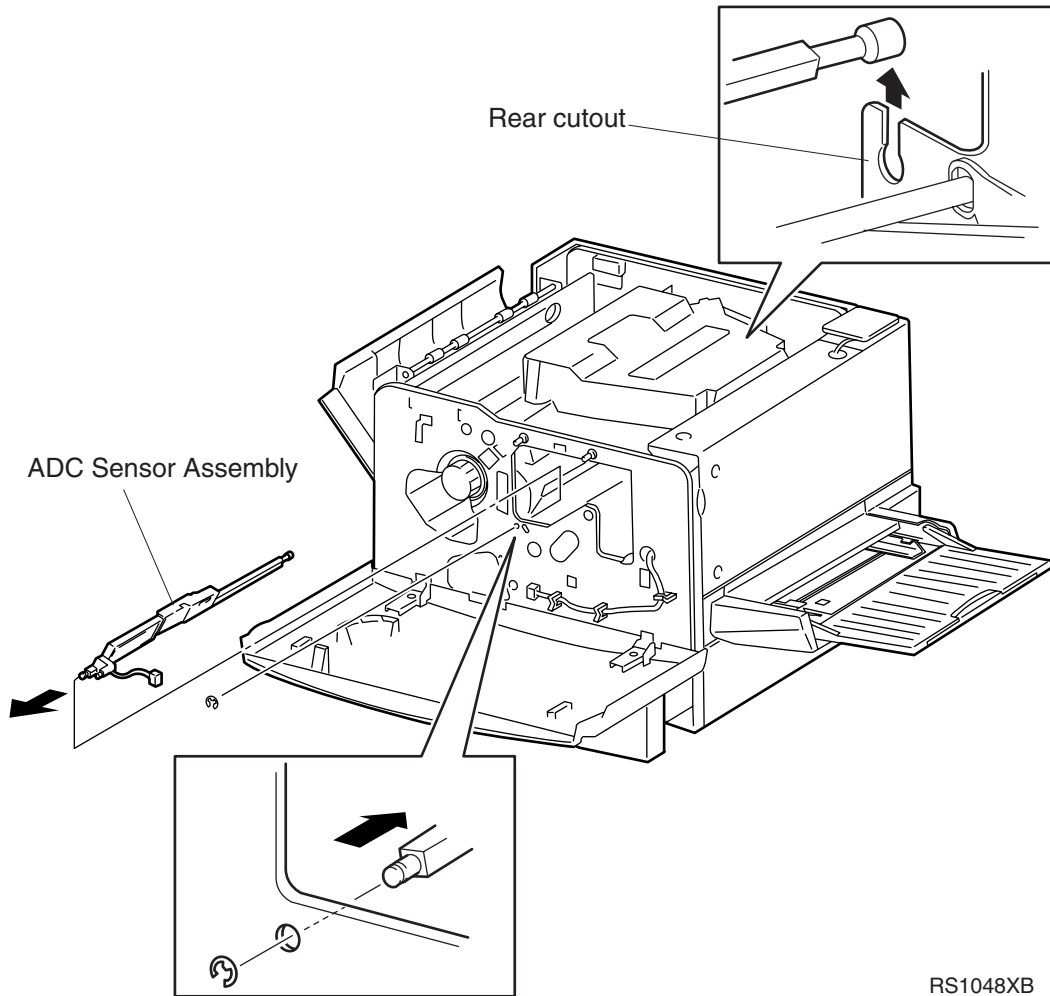

RS1048XB

RS1048XB



## RRP 9.50 ADC Sensor Assembly (PL6.1.20)

---

### Removal

1. Remove the Xerographic Cartridge (RRP 9.48).
2. Remove the Inner Cover Assembly (RRP 9.2).
3. Disconnect P/J 81 from the ADC Sensor Assembly.
4. Remove the E ring securing the front of the ADC Sensor Assembly to the front of the printer frame.
5. Reach inside the printer cavity and slide the front end of the ADC Sensor out of the hole at the front of the printer.
6. Pull the wire harness and P/J 81 out through the grommet hole.
7. Lift the rear end of the ADC Sensor out of the cutout at the rear of the printer and remove the ADC Sensor.



*The IBT is located next to the ADC Sensor Assembly. The IBT is easily scratched. When removing the ADC Sensor be extremely careful that you do not touch the surface of the IBT with your fingers or with the ADC Sensor Assembly.*

### Replacement

1. Slide the shaft end of the ADC Sensor Assembly into the slot at the rear of the printer cavity.
2. Push the shaft far enough to the rear for you to slide the front of the shaft into the hole in the front of the printer frame and the positioning tab into the slot next to the hole.
3. Slide the rear of the shaft down into the rear slot.
4. Insert P/J 81 through the grommet hole.
5. Use an E ring to secure the front of the ADC Sensor Assembly to the front of the printer frame.
6. Reconnect P/J 81.
7. Reinstall the Inner Cover Assembly (RRP 9.2).
8. Reinstall the Xerographic Cartridge (RRP 9.48).

## RRP 9.51 Erase Lamp Assembly (PL6.1.30)

---

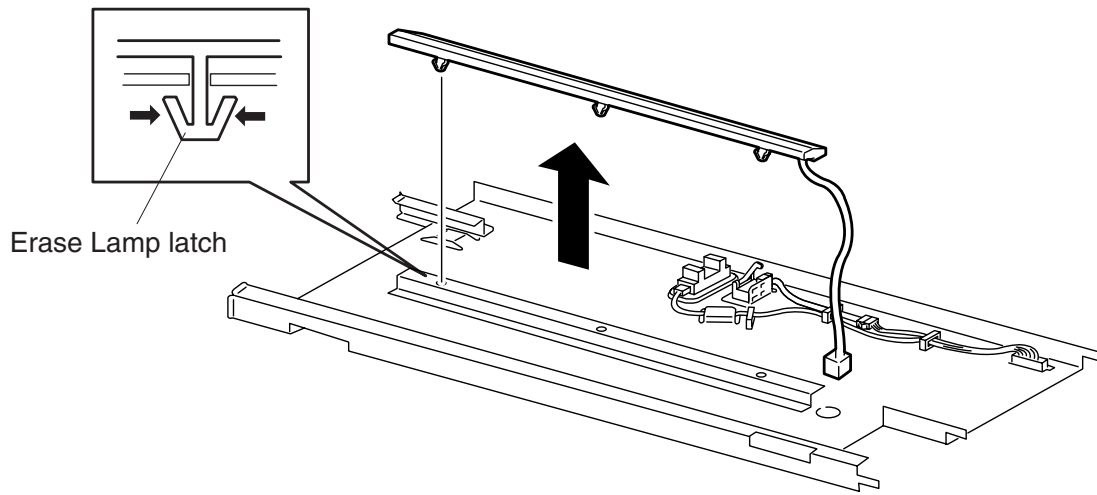

RS1049XB

RS1049XB

## **RRP 9.51 Erase Lamp Assembly (PL6.1.30)**

---

### **Removal**

1. Remove the XL Rail Assembly (RRP 9.52).
2. Use a screwdriver to release the three latches holding the Erase Lamp Assembly to the XL Rail Assembly and remove the Lamp.

### **Replacement**

1. Route the Erase Lamp wire through the hole in the top of the printer frame.
2. Position the Erase Lamp against the XL Rail Assembly so the three latches on the Lamp line up with the three holes in the Rail Assembly.
3. Press the Erase Lamp Assembly against the Rail Assembly so the three latches snap into place.
4. Reinstall the XP Rail Assembly (RRP 9.52).

## RRP 9.52 XL Rail Assembly (PL6.1.40)

---

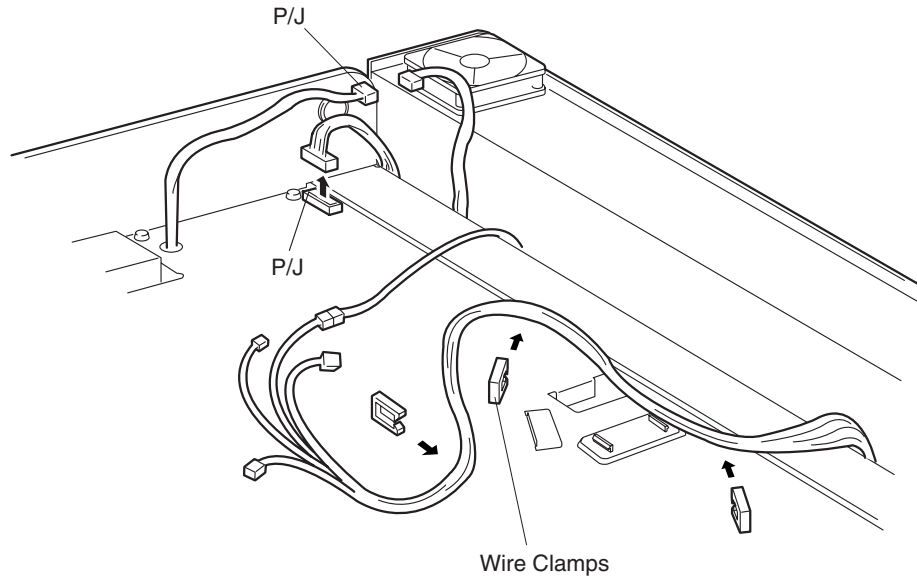

Figure 1

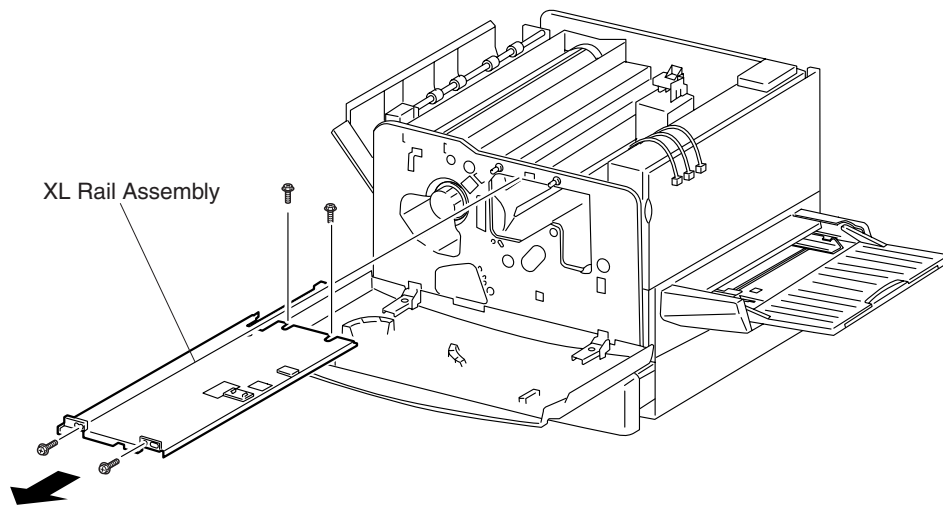

Figure 2

RS1050XB

RS1050XB

## **RRP 9.52 XL Rail Assembly (PL6.1.40)**

---

### **Removal**

1. Remove the Xerographic Cartridge (RRP 9.48).
2. Remove the ROS Assembly (RRP 9.47).
3. Disconnect P/J 83 from the Waste Toner Sensor.
4. Disconnect P/J 89 from the Toner Box Sensor.
5. Free the wire harnesses from the wire clamps (Figure 1).
6. Disconnect P/J 86 from the Erase Lamp.
7. Remove the two screws securing the XL Rail Assembly to the front of the printer frame (Figure 2).
8. Remove the two screws securing the XL Rail Assembly to the rear of the printer frame
9. Lift the XL Rail Assembly up through the top of the printer frame.

### **Replacement**

1. Move all of the wire harnesses out of the way.
2. Lower the XL Rail Assembly drop through the top of the printer frame.
3. Insert the three tabs that are located at the rear of the XL Rail Assembly into the three holes at the rear of the printer frame.
4. Position the front lip of the XL Rail Assembly so it is on the outside front of the printer frame.
5. Line up the four screw holes in the XL Rail Assembly with the four screw holes in the printer frame.
6. Use four screws to secure the Assembly to the printer frame.
7. Reconnect P/J 86 to the Erase Lamp.
8. Reconnect P/J 89 to the Toner Box Sensor.
9. Reconnect P/J 83 to the Waste Toner Sensor.
10. Secure P/J 83 and P/J 86 under the wire clamps.
11. Reinstall the ROS Assembly (RRP 9.47).
12. Reinstall the Xerographic Cartridge (RRP 9.48).

## RRP 9.53 Waste Toner Sensor (PL6.1.42)

---

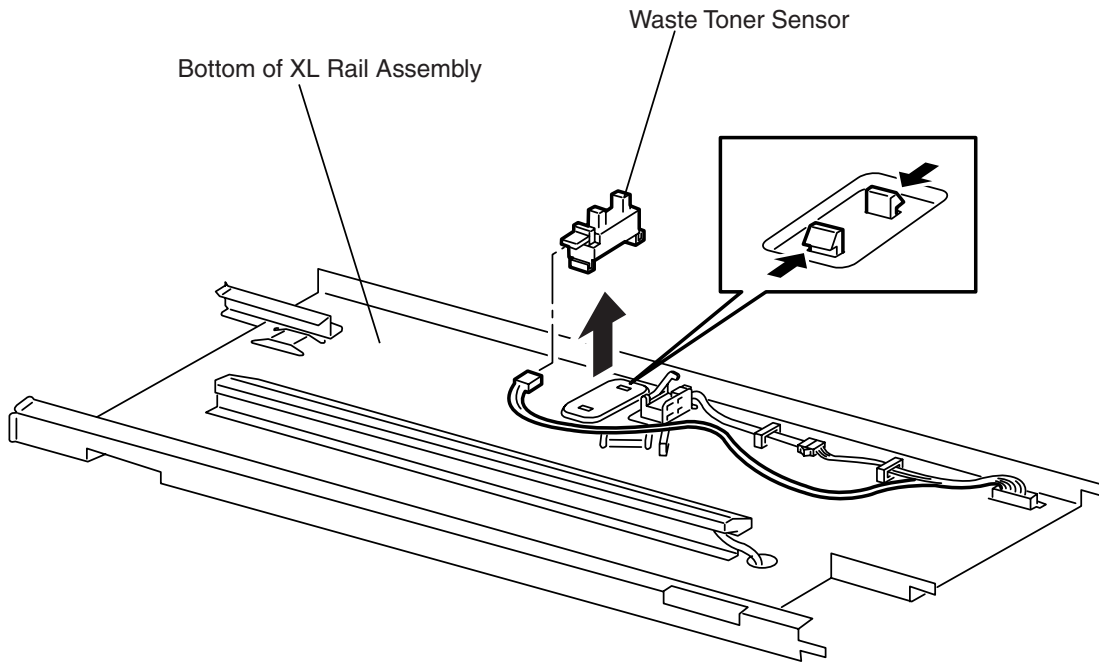

RS1057XB

RS1057XB

## **RRP 9.53 Waste Toner Sensor (PL6.1.42)**

---

### **Removal**

1. Remove the XL Rail Assembly (RRP 9.52).
2. Squeeze in both Sensor latch arms as you push down to free the Waste Toner Sensor from the XL Rail Assembly.

### **Replacement**

1. Position the Waste Toner Sensor on the XL Rail Assembly so the P/J faces the Erase Lamp Assembly.
2. Press the two Sensor latch arms into the cutouts in the XL Rail Assembly.  
The Sensor snaps into place.
3. Reinstall the XL Rail Assembly (RRP 9.52).

## RRP 9.54 Toner Box Sensor (PL6.1.43)

---

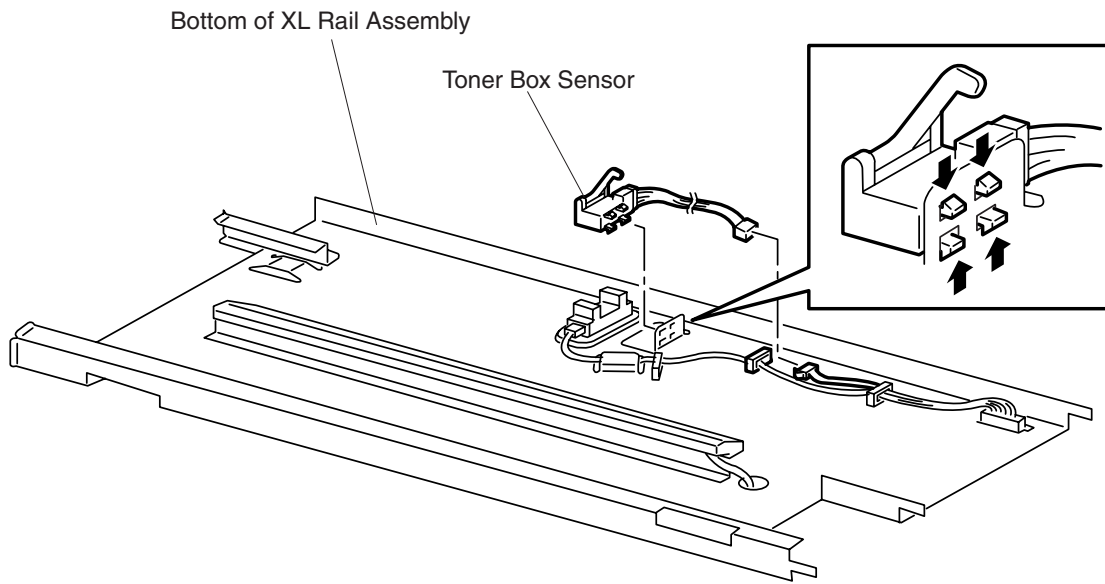

RS1058XB

RS1058XB



## **RRP 9.54 Toner Box Sensor (PL6.1.43)**

---

### **Removal**

1. Remove the XL Rail Assembly (RRP 9.52).
2. Squeeze the four Sensor latch arms as you push the Toner Box Sensor free from the XL Rail Assembly.
3. Disconnect P/J 83 from the Sensor.

### **Replacement**

1. Position the Toner Box Sensor on the XL Rail Assembly so the P/J faces away from the Erase Lamp Assembly and the Toner Box Sensor Actuator points up.
2. Press the four Sensor latch arms into the cutouts in the XL Rail Assembly.  
The Sensor snaps into place.
3. Reconnect P/J 83 to the Sensor.
4. Reinstall the XL Rail Assembly (RRP 9.52).

## RRP 9.55 Yellow (Y) Toner Cartridge (PL7.1.1)

---

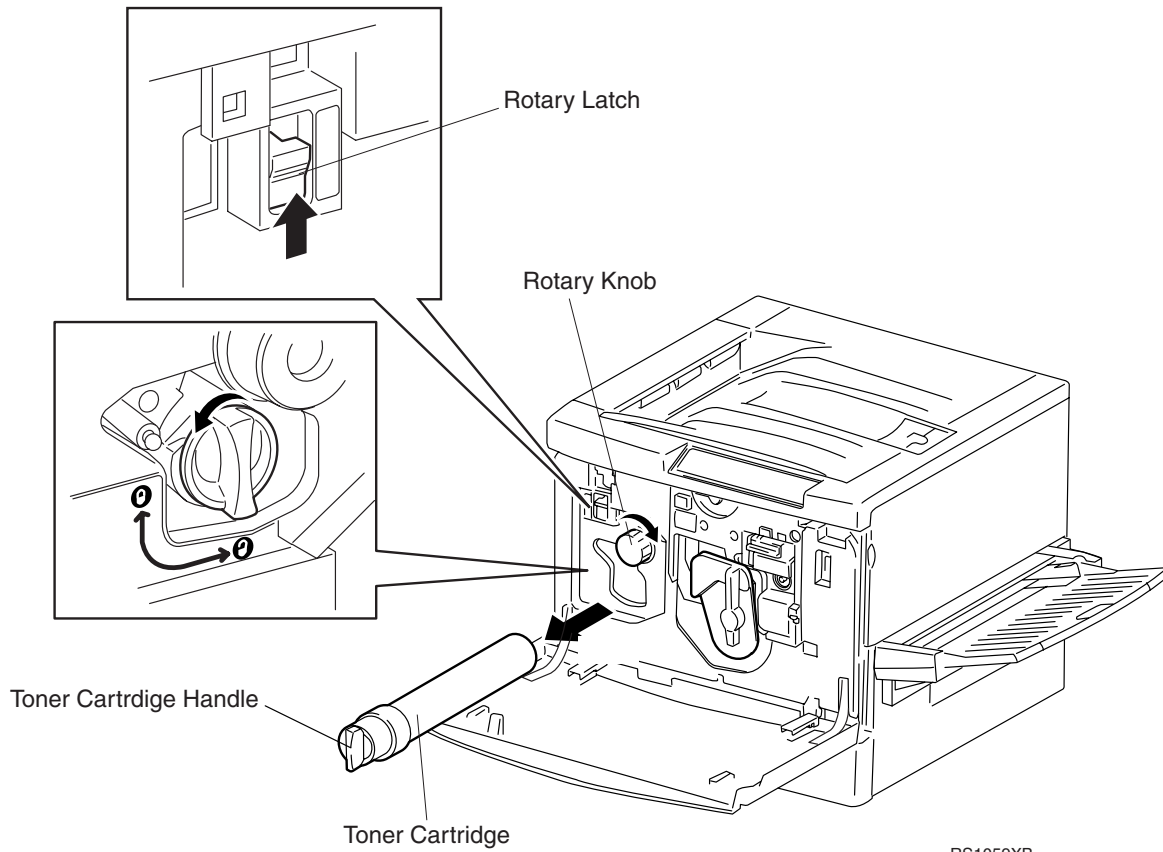

RS1059XB

RS1059XB

## **RRP 9.55 Yellow (Y) Toner Cartridge (PL7.1.1)**

---

### **Removal**

1. Open the Front Cover.
2. Push up and hold the Rotary Latch Lever that is located above and to the left of the Rotary Knob.
3. Turn the Rotary Knob in the direction of the arrows printed on the Knob.
4. Stop turning the Knob when the Yellow Toner Cartridge is lined up within the cutout just below the Rotary Knob.  
The end of the Yellow Toner Cartridge is yellow, as is the end of the Yellow Developer Housing the Cartridge fits into.
5. Release the Rotary Latch Lever.
6. Turn the Yellow Toner Cartridge handle counterclockwise until it stops.
7. Pull the Yellow Toner Cartridge out of the printer.
8. If you are replacing an old Yellow Toner Cartridge with a new one, dispose of the old Cartridge according to the instructions presented in the Renoir User Manual.

### **Replacement**

1. If you are replacing an old Yellow Toner Cartridge with a new one, prepare the new Cartridge according to the instructions presented in the Renoir User Manual.
2. Open the Front Cover.
3. Push up and hold the Rotary Latch Lever that is located above and to the left of the Rotary Knob.
4. Turn the Rotary Knob in the direction of the arrows printed on the Knob.
5. Stop turning the Knob when the Yellow Developer Housing is lined up within the cutout just below the Rotary Knob.  
The end of the Yellow Developer Housing is yellow.
6. Release the Rotary Latch Lever.
7. Position the Yellow Toner Cartridge so the printed arrow is on the top of the Cartridge and is facing the printer.
8. Slide the Cartridge as far as it will go into the printer.
9. Turn the Yellow Toner Cartridge handle clockwise until it stops.  
The Yellow Toner Cartridge is now locked in place.
10. Close the Front Cover.

## RRP 9.56 Magenta (M) Toner Cartridge (PL7.1.2)

---

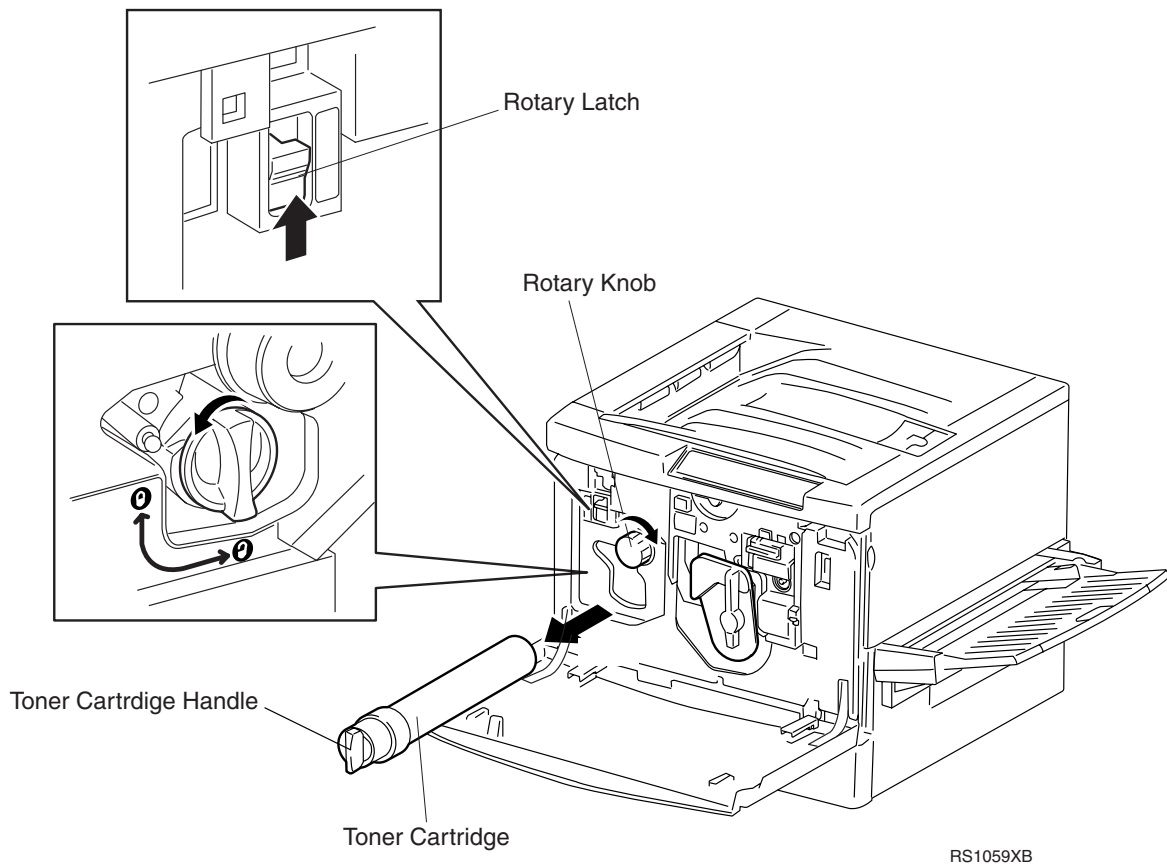

RS1059XB

## **RRP 9.56 Magenta (M) Toner Cartridge (PL7.1.2)**

---

### **Removal**

1. Open the Front Cover.
2. Push up and hold the Rotary Latch Lever that is located above and to the left of the Rotary Knob.
3. Turn the Rotary Knob in the direction of the arrows printed on the Knob.
4. Stop turning the Knob when the Magenta Toner Cartridge is lined up within the cutout just below the Rotary Knob.  
The end of the Magenta Toner Cartridge is magenta, as is the end of the Magenta Developer Housing the Cartridge fits into.
5. Release the Rotary Latch Lever.
6. Turn the Magenta Toner Cartridge handle counterclockwise until it stops.
7. Pull the Magenta Toner Cartridge out of the printer.
8. If you are replacing an old Magenta Toner Cartridge with a new one, dispose of the old Cartridge according to the instructions presented in the Renoir User Manual.

### **Replacement**

1. If you are replacing an old Magenta Toner Cartridge with a new one, prepare the new Cartridge according to the instructions presented in the Renoir User Manual.
2. Open the Front Cover.
3. Push up and hold the Rotary Latch Lever that is located above and to the left of the Rotary Knob.
4. Turn the Rotary Knob in the direction of the arrows printed on the Knob.
5. Stop turning the Knob when the Magenta Developer Housing is lined up within the cutout just below the Rotary Knob.  
The end of the Magenta Developer Housing is magenta.
6. Release the Rotary Latch Lever.
7. Position the Magenta Toner Cartridge so the printed arrow is on the top of the Cartridge and is facing the printer.
8. Slide the Cartridge as far as it will go into the printer.
9. Turn the Magenta Toner Cartridge handle clockwise until it stops.  
The Magenta Toner Cartridge is now locked in place.
10. Close the Front Cover.

## RRP 9.57 Cyan (C) Toner Cartridge (PL7.1.3)

---

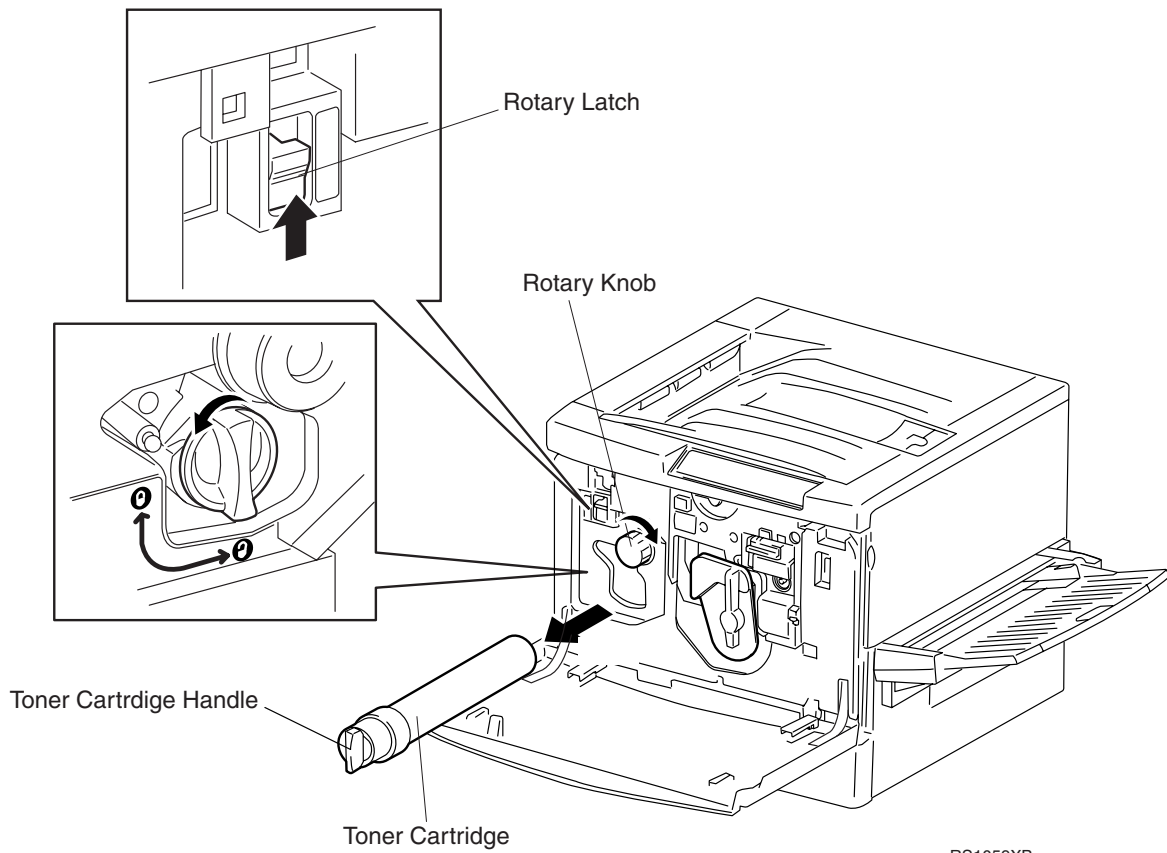

RS1059XB

## RRP 9.57 Cyan (C) Toner Cartridge (PL7.1.3)

---

### Removal

1. Open the Front Cover.
2. Push up and hold the Rotary Latch Lever that is located above and to the left of the Rotary Knob.
3. Turn the Rotary Knob in the direction of the arrows printed on the Knob.
4. Stop turning the Knob when the Cyan Toner Cartridge is lined up within the cutout just below the Rotary Knob.  
The end of the Cyan Toner Cartridge is cyan, as is the end of the Cyan Developer Housing the Cartridge fits into.
5. Release the Rotary Latch Lever.
6. Turn the Cyan Toner Cartridge handle counterclockwise until it stops.
7. Pull the Cyan Toner Cartridge out of the printer.
8. If you are replacing an old Cyan Toner Cartridge with a new one, dispose of the old Cartridge according to the instructions presented in the Renoir User Manual.

### Replacement

1. If you are replacing an old Cyan Toner Cartridge with a new one, prepare the new Cartridge according to the instructions presented in the Renoir User Manual.
2. Open the Front Cover.
3. Push up and hold the Rotary Latch Lever that is located above and to the left of the Rotary Knob.
4. Turn the Rotary Knob in the direction of the arrows printed on the Knob.
5. Stop turning the Knob when the Cyan Developer Housing is lined up within the cutout just below the Rotary Knob.  
The end of the Cyan Developer Housing is cyan.
6. Release the Rotary Latch Lever.
7. Position the Cyan Toner Cartridge so the printed arrow is on the top of the Cartridge and is facing the printer.
8. Slide the Cartridge as far as it will go into the printer.
9. Turn the Cyan Toner Cartridge handle clockwise until it stops.  
The Cyan Toner Cartridge is now locked in place.
10. Close the Front Cover.

## RRP 9.58 Black (K) Toner Cartridge (PL7.1.4)

---

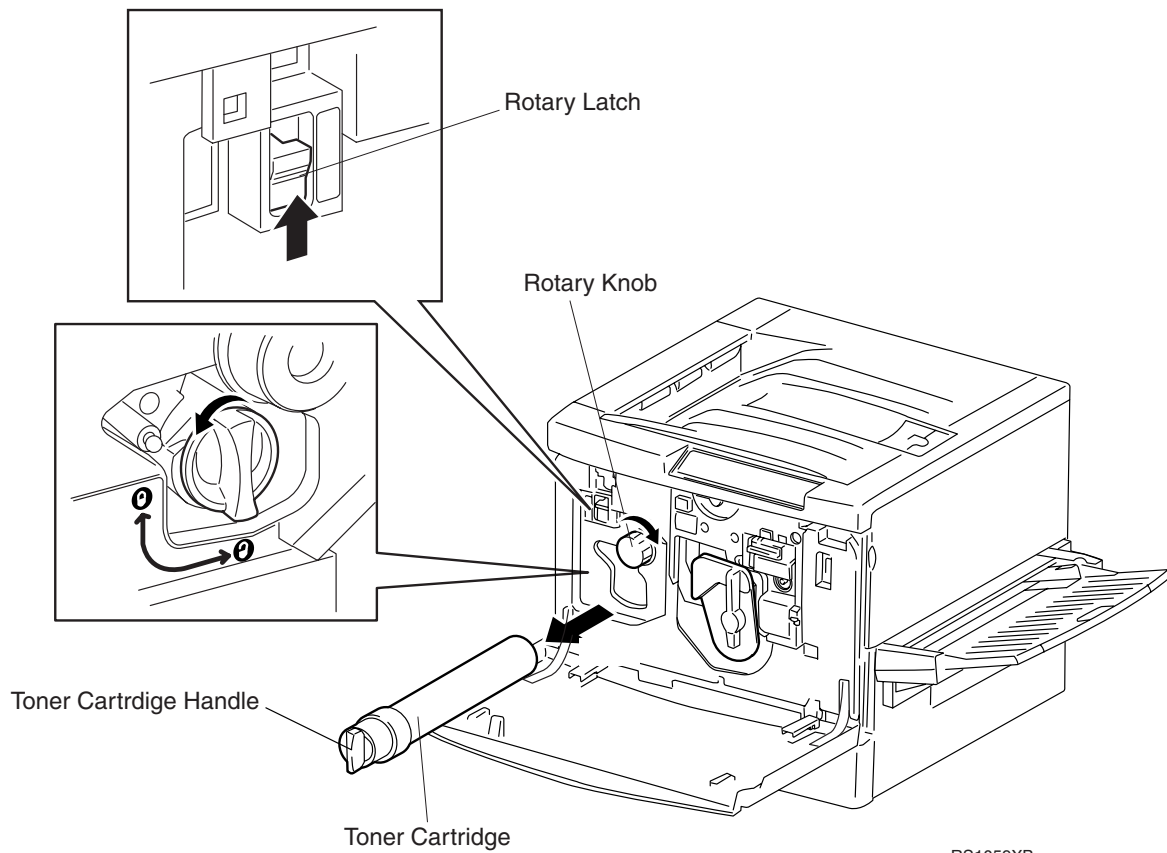

RS1059XB



## **RRP 9.58 Black (K) Toner Cartridge (PL7.1.4)**

---

### **Removal**

1. Open the Front Cover.
2. Push up and hold the Rotary Latch Lever that is located above and to the left of the Rotary Knob.
3. Turn the Rotary Knob in the direction of the arrows printed on the Knob.
4. Stop turning the Knob when the Black Toner Cartridge is lined up within the cutout just below the Rotary Knob.  
The end of the Black Toner Cartridge is black, as is the end of the Black Developer Housing the Cartridge fits into.
5. Release the Rotary Latch Lever.
6. Turn the Black Toner Cartridge handle counterclockwise until it stops.
7. Pull the Black Toner Cartridge out of the printer.
8. If you are replacing an old Black Toner Cartridge with a new one, dispose of the old Cartridge according to the instructions presented in the Renoir User Manual.

### **Replacement**

1. If you are replacing an old Black Toner Cartridge with a new one, prepare the new Cartridge according to the instructions presented in the Renoir User Manual.
2. Open the Front Cover.
3. Push up and hold the Rotary Latch Lever that is located above and to the left of the Rotary Knob.
4. Turn the Rotary Knob in the direction of the arrows printed on the Knob.
5. Stop turning the Knob when the Black Developer Housing is lined up within the cutout just below the Rotary Knob.  
The end of the Black Developer Housing is black.
6. Release the Rotary Latch Lever.
7. Position the Black Toner Cartridge so the printed arrow is on the top of the Cartridge and is facing the printer.
8. Slide the Cartridge as far as it will go into the printer.
9. Turn the Black Toner Cartridge handle clockwise until it stops.  
The Black Toner Cartridge is now locked in place.
10. Close the Front Cover.

## RRP 9.59 Yellow (Y) Developer Assembly (PL7.1.10)

---

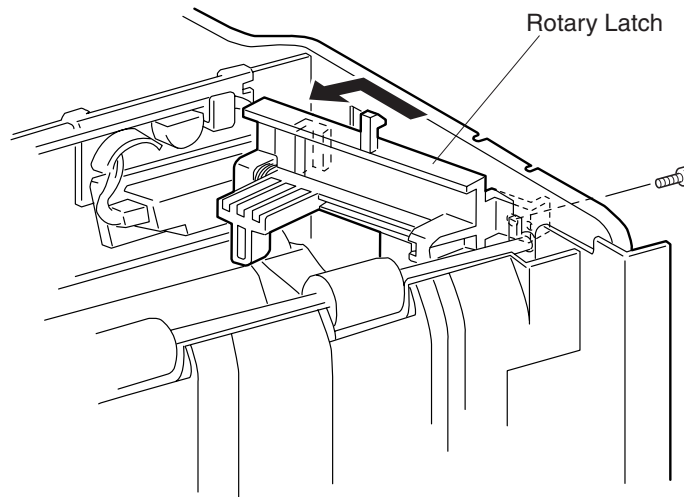

Figure 1

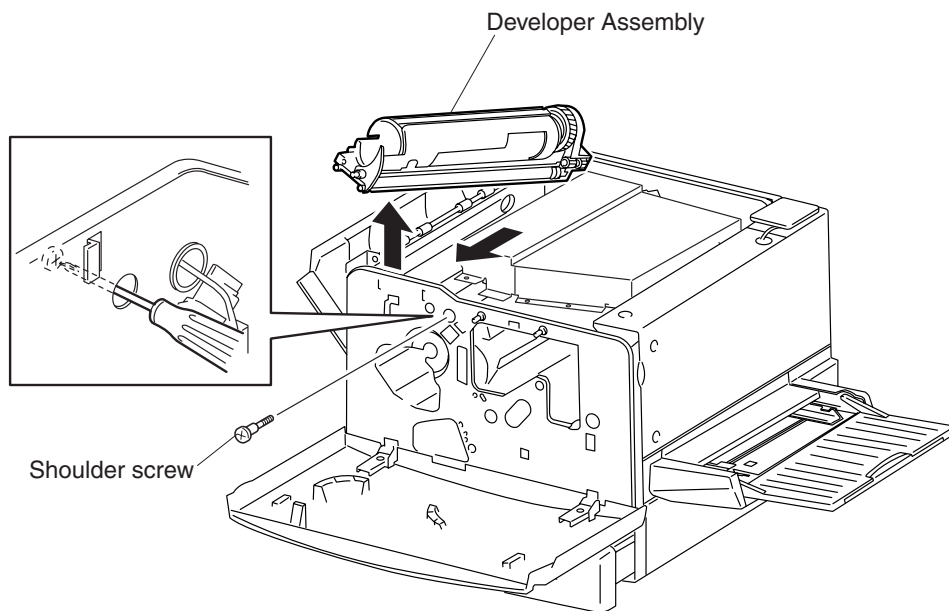

Figure 2

RS1060XB

RS1060XB

## RRP 9.59 Yellow (Y) Developer Assembly (PL7.1.10)

---

### Removal

1. Open the Front Cover.
2. Remove the Yellow Toner Cartridge (RRP 9.55).
3. Remove the Xerographic Cartridge (RRP 9.48).
4. Remove the Top Cover Assembly (RRP 9.3).
5. Remove the Inner Cover Assembly (RRP 9.2).
6. Remove the Used Cartridge Sensor (RRP 9.70).
7. Remove the screw securing the Rotary Latch to the front of the printer frame and remove the Latch (Figure 1).
8. Turn the Rotary Knob until the large, shoulder screw securing the Yellow Developer Assembly to the Rotary Frame appears through the access hole a few inches above the Rotary Knob (Figure 2).
9. Remove the shoulder screw securing the Yellow Developer Assembly to the Rotary Frame.
10. Reaching in through the top of the printer, slide the Yellow Developer Assembly to the front of the printer to free the gears at the rear of the Developer Assembly.
11. Make sure you do not damage the Exit Actuator as you lift the front of the Yellow Developer Assembly to free the front of the Assembly from the front of the printer frame, and remove the Assembly.

### Replacement

1. Turn the Rotary Knob until you can access the Yellow Developer Assembly cavity through the top of the printer.  
There is a "Y" molded into the rear of the Yellow Developer Assembly cavity.
2. Hold the Yellow Developer Assembly so the rear, or gear end, of the Assembly is slightly lower than the front.
3. Slide the rear of the Assembly into the locating pins located at the rear of the Yellow Developer Assembly.
4. Lower the front end of the Assembly making sure you do not damage the Exit Actuator.
5. Reposition the Yellow Developer Assembly until the Assembly seats firmly in the Rotary Frame and the screw hole at the front of the Assembly lines up with the screw hole at the front of the Rotary Frame.
6. Turn the Rotary Knob until the screw hole in the front of the Yellow Developer Assembly appears through the access hole a few inches above the Rotary Knob.
7. Use a large, shoulder screw to secure the Yellow Developer Assembly to the Rotary Frame.
8. Reinstall the Used Cartridge Sensor (RRP 9.70).
9. Reinstall the Rotary Latch to the front of the printer frame and use one screw to secure the Latch to the frame.
10. Reinstall the Inner Cover Assembly (RRP 9.2).
11. Reinstall the Top Cover Assembly (RRP 9.3).
12. Reinstall the Xerographic Cartridge (RRP 9.48).
13. Reinstall the Yellow Toner Cartridge (RRP 9.55).
14. Close the Front Cover.

## RRP 9.60 Yellow (Y) Developer (PL7.1.13)

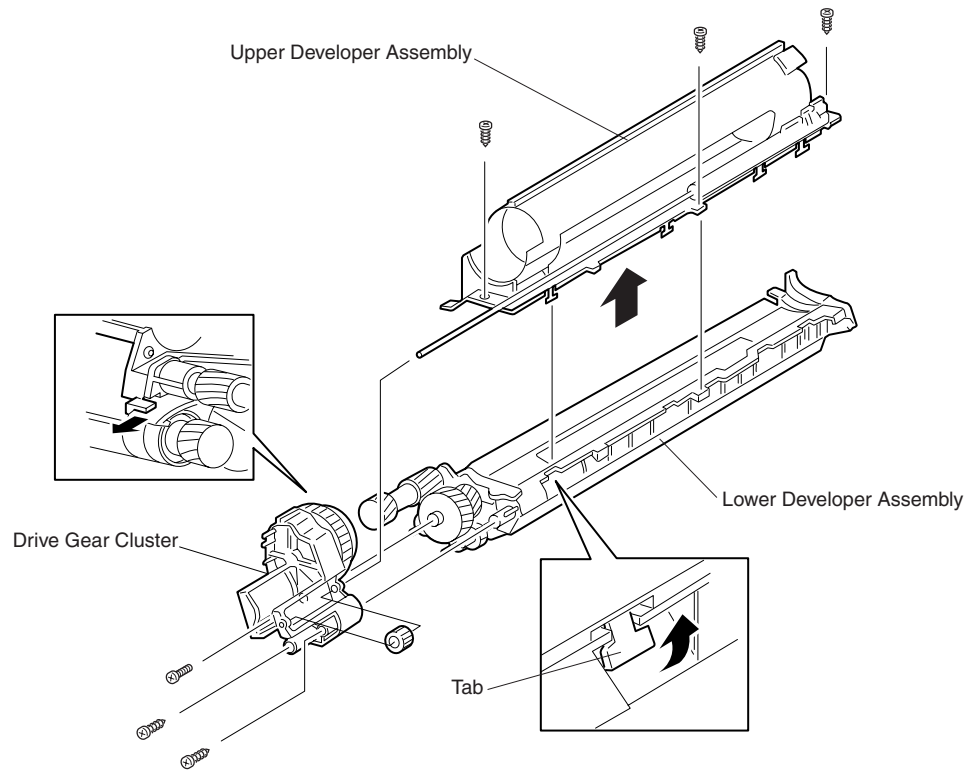

Figure 1

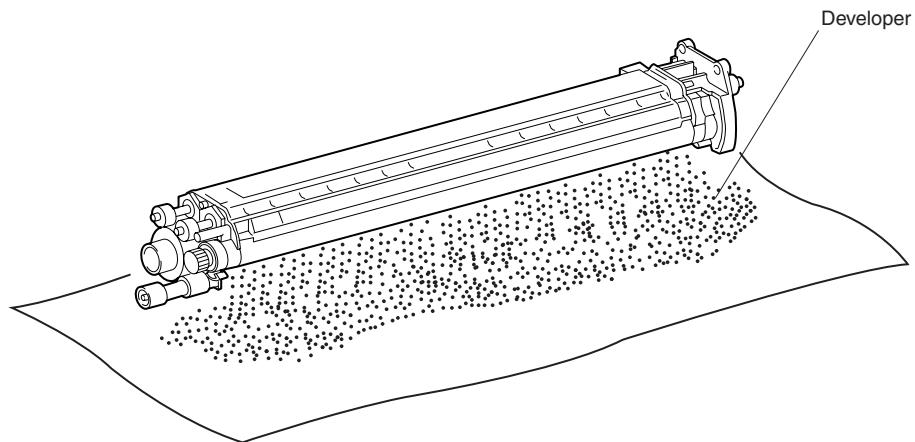

Figure 2

RS1061XB

RS1061XB

## RRP 9.60 Yellow (Y) Developer (PL7.1.13)

---

### Removal

1. Remove the Yellow Developer Assembly (RRP 9.59).
2. Place the Yellow Developer Assembly, with the Magnet Roll down, on a flat and stable work surface.
3. Remove the three screws securing the Gear Cluster at the end of the Developer Assembly and remove the Cluster.
4. Remove the three screws securing the Upper Developer Assembly to the Lower Developer Assembly.
5. Gently release the four tabs that are located on one side of the Yellow Developer Assembly as you pry the Upper Developer Assembly off of the Lower Developer Assembly.
6. Turn the Developer Assembly upside down and pour the Developer onto a disposable towel or newspaper.
7. Discard the Developer according to company policy.



**Do not dispose of the Developer in an open fire.**

### Replacement

1. Pour Yellow Developer evenly along the Developer Assembly Auger.
2. Rotate the Auger Gear so the Auger turns and spreads the developer along the Assembly channel and Magnet Roll.
3. Reinstall the Upper Developer Assembly on top of the Lower Developer Assembly by first sliding the Dispense Shaft that is sticking out of one end of the Upper Assembly into the Auger Dispense Gear that is attached to the Lower Assembly.
4. Slide the two tabs that are located on the ends of the Upper Assembly under the two tabs that are located on the ends of the Lower Assembly, immediately above the Magnet Roll.
5. Seat the Upper Assembly onto the Lower Assembly so the three screw holes in the Upper Assembly line up with the three screw holes in the Lower Assembly.
6. Hook the four tabs that are on one side of the Upper Developer Assembly onto the four notches that are located on the Lower Developer Assembly.
7. Make sure the Upper Developer Assembly is seated firmly on top of the Lower Developer Assembly and that all tabs and latches are securely in place.
8. Use three screws to secure the Upper Developer Assembly to the Lower Developer Assembly.
9. Rotate the Developer Assembly gears so the Magnet Roll turns and the Developer forms an even brush on the Roll.
10. Reinstall the Yellow Developer Assembly (RRP 9.59).

## RRP 9.61 Magenta (M) Developer Assembly (PL7.1.20)

---

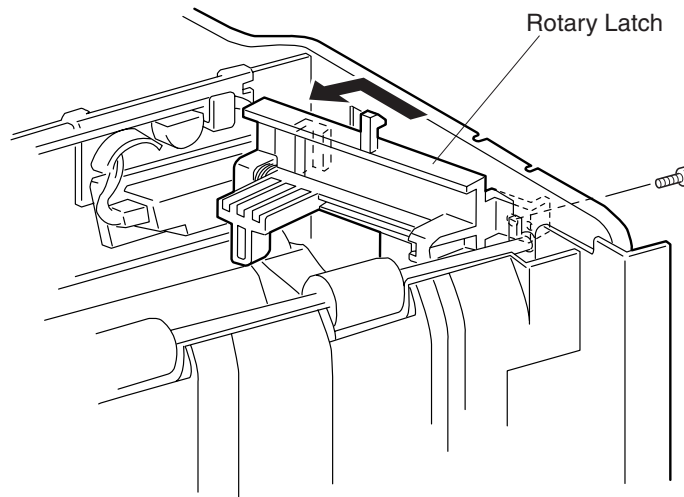

Figure 1

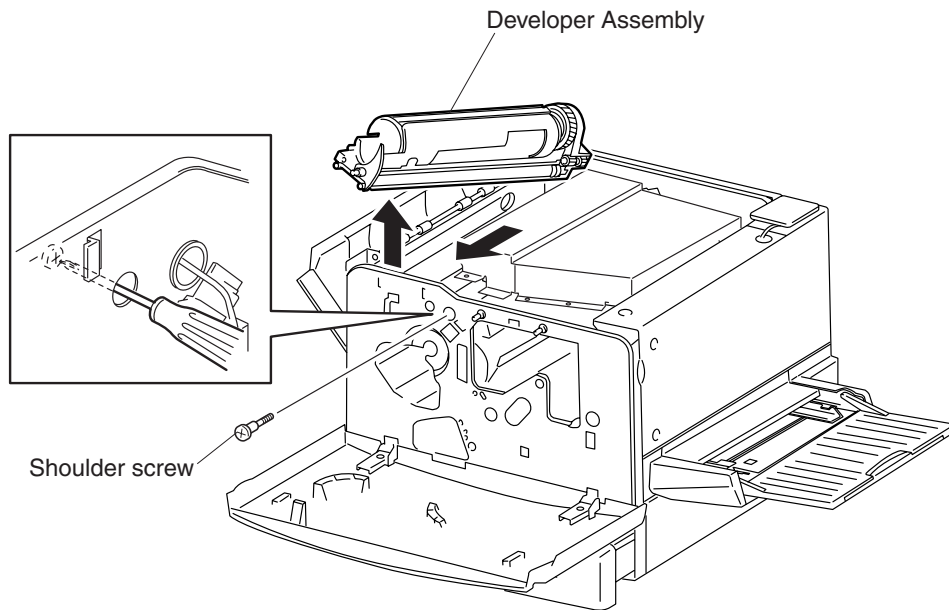

Figure 2

RS1060XB

RS1060XB

## **RRP 9.61 Magenta (M) Developer Assembly (PL7.1.20)**

---

### **Removal**

1. Open the Front Cover.
2. Remove the Magenta Toner Cartridge (RRP 9.56).
3. Remove the Xerographic Cartridge (RRP 9.48).
4. Remove the Top Cover Assembly (RRP 9.3).
5. Remove the Inner Cover Assembly (RRP 9.2).
6. Remove the Used Cartridge Sensor (RRP 9.70).
7. Remove the screw securing the Rotary Latch to the front of the printer frame and remove the Latch (Figure 1).
8. Turn the Rotary Knob until the large, shoulder screw securing the Magenta Developer Assembly to the Rotary Frame appears through the access hole a few inches above the Rotary Knob (Figure 2).
9. Remove the shoulder screw securing the Magenta Developer Assembly to the Rotary Frame.
10. Reaching in through the top of the printer, slide the Magenta Developer Assembly to the front of the printer to free the gears at the rear of the Developer Assembly.
11. Make sure you do not damage the Exit Actuator as you lift the front of the Magenta Developer Assembly to free the front of the Assembly from the front of the printer frame, and remove the Assembly.

### **Replacement**

1. Turn the Rotary Knob until you can access the Magenta Developer Assembly cavity through the top of the printer.  
There is a "M" molded into the rear of the Magenta Developer Assembly cavity.
2. Hold the Magenta Developer Assembly so the rear, or gear end, of the Assembly is slightly lower than the front.
3. Slide the rear of the Assembly into the locating pins located at the rear of the Magenta Developer Assembly.
4. Lower the front end of the Assembly making sure you do not damage the Exit Actuator.
5. Reposition the Magenta Developer Assembly until the Assembly seats firmly in the Rotary Frame and the screw hole at the front of the Assembly lines up with the screw hole at the front of the Rotary Frame.
6. Turn the Rotary Knob until the screw hole in the front of the Magenta Developer Assembly appears through the access hole a few inches above the Rotary Knob.
7. Use a large, shoulder screw to secure the Magenta Developer Assembly to the Rotary Frame.
8. Reinstall the Used Cartridge Sensor (RRP 9.70).
9. Reinstall the Rotary Latch to the front of the printer frame and use one screw to secure the Latch to the frame.
10. Reinstall the Inner Cover Assembly (RRP 9.2).
11. Reinstall the Top Cover Assembly (RRP 9.3).
12. Reinstall the Xerographic Cartridge (RRP 9.48).
13. Reinstall the Magenta Toner Cartridge (RRP 9.56).
14. Close the Front Cover.

## RRP 9.62 Magenta (M) Developer (PL7.1.23)

---

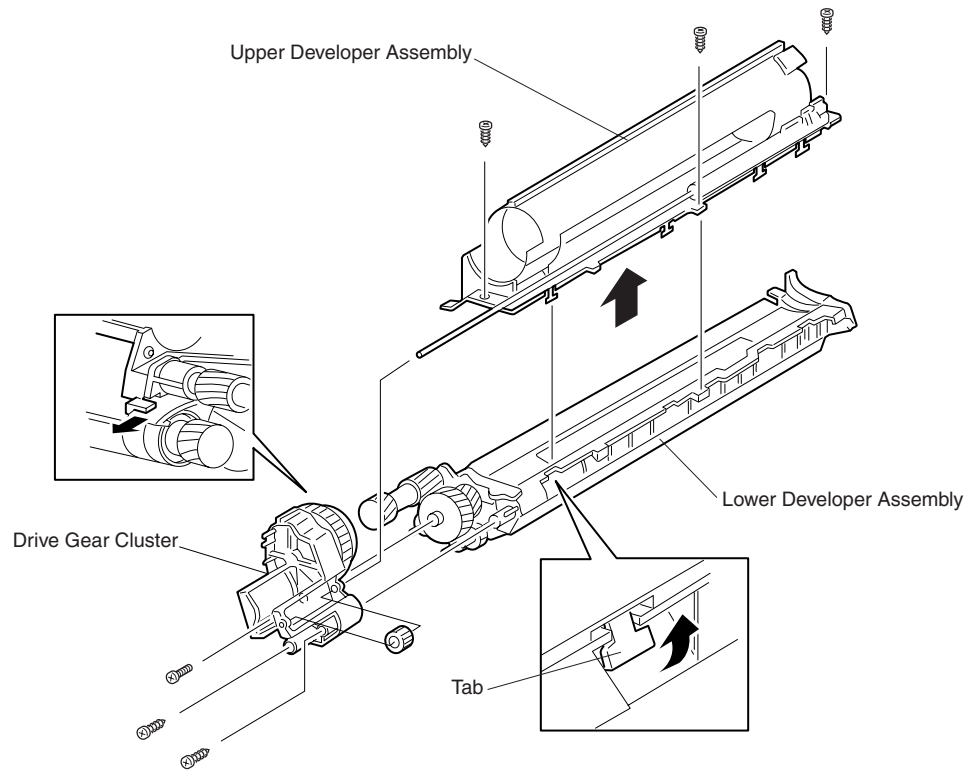

Figure 1

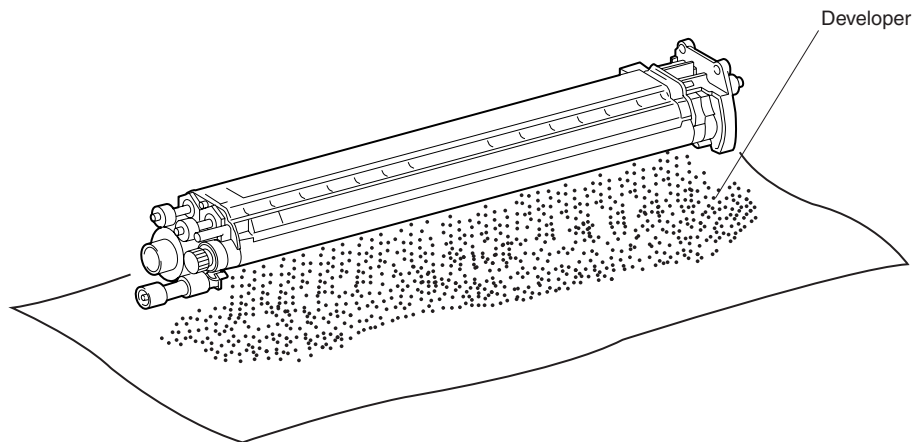

Figure 2

RS1061XB

RS1061XB



## RRP 9.62 Magenta (M) Developer (PL7.1.23)

---

### Removal

1. Remove the Magenta Developer Assembly (RRP 9.61).
2. Place the Magenta Developer Assembly, with the Magnet Roll down, on a flat and stable work surface.
3. Remove the three screws securing the Gear Cluster at the end of the Developer Assembly and remove the Cluster.
4. Remove the three screws securing the Upper Developer Assembly to the Lower Developer Assembly.
5. Gently release the four tabs that are located on one side of the Magenta Developer Assembly as you pry the Upper Developer Assembly off of the Lower Developer Assembly.
6. Turn the Developer Assembly upside down and pour the Developer onto a disposable towel or newspaper.
7. Discard the Developer according to company policy.



**Do not dispose of the Developer in an open fire.**

### Replacement

1. Pour Magenta Developer evenly along the Developer Assembly Auger.
2. Rotate the Auger Gear so the Auger turns and spreads the developer along the Assembly channel and Magnet Roll.
3. Reinstall the Upper Developer Assembly on top of the Lower Developer Assembly by first sliding the Dispense Shaft that is sticking out of one end of the Upper Assembly into the Auger Dispense Gear that is attached to the Lower Assembly.
4. Slide the two tabs that are located on the ends of the Upper Assembly under the two tabs that are located on the ends of the Lower Assembly, immediately above the Magnet Roll.
5. Seat the Upper Assembly onto the Lower Assembly so the three screw holes in the Upper Assembly line up with the three screw holes in the Lower Assembly.
6. Hook the tabs clips that are on one side of the Upper Developer Assembly onto the four notches that are located on the Lower Developer Assembly.
7. Make sure the Upper Developer Assembly is seated firmly on top of the Lower Developer Assembly and that all tabs and latches are securely in place.
8. Use three screws to secure the Upper Developer Assembly to the Lower Developer Assembly.
9. Rotate the Developer Assembly gears so the Magnet Roll turns and the Developer forms an even brush on the Roll.
10. Reinstall the Magenta Developer Assembly (RRP 9.61).

## RRP 9.63 Cyan (C) Developer Assembly (PL7.1.30)

---

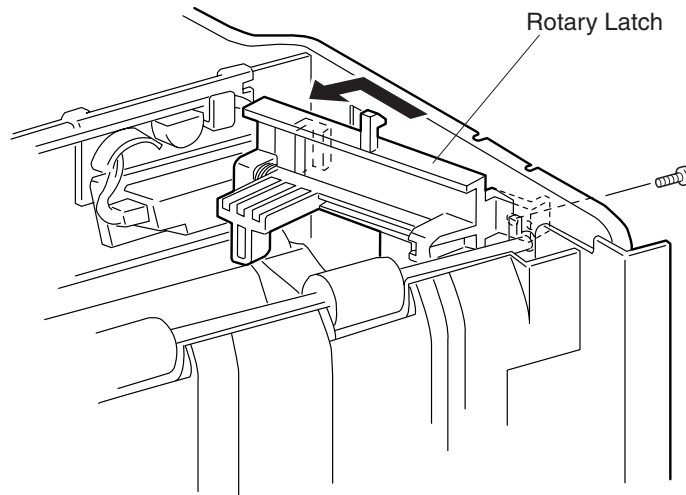

Figure 1

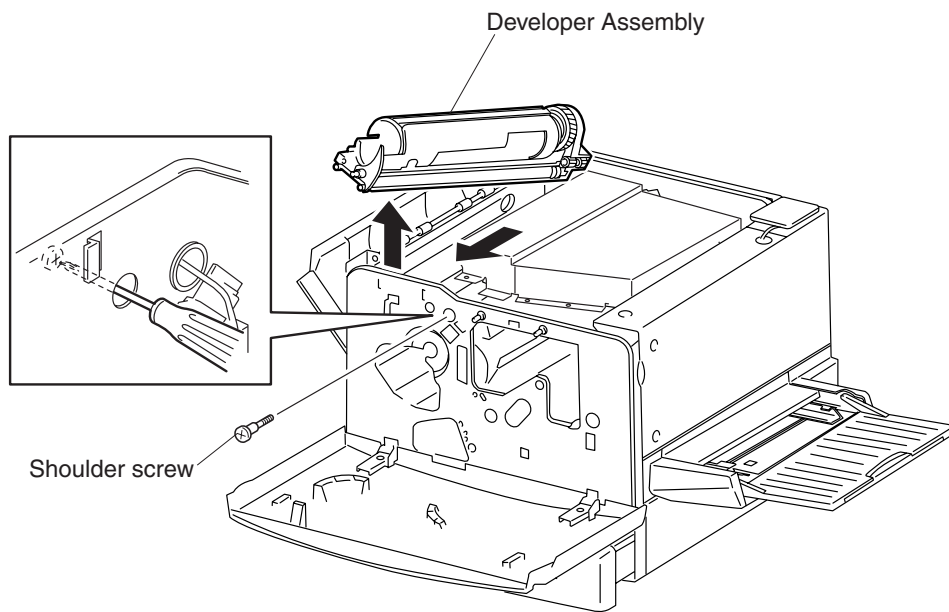

Figure 2

RS1060XB

RS1060XB

## **RRP 9.63 Cyan (C) Developer Assembly (PL7.1.30)**

---

### **Removal**

1. Open the Front Cover.
2. Remove the Cyan Toner Cartridge (RRP 9.57).
3. Remove the Xerographic Cartridge (RRP 9.48).
4. Remove the Top Cover Assembly (RRP 9.3).
5. Remove the Inner Cover Assembly (RRP 9.2).
6. Remove the Used Cartridge Sensor (RRP 9.70).
7. Remove the screw securing the Rotary Latch to the front of the printer frame and remove the Latch.
8. Turn the Rotary Knob until the large, shoulder screw securing the Cyan Developer Assembly to the Rotary Frame appears through the access hole a few inches above the Rotary Knob.
9. Remove the shoulder screw securing the Cyan Developer Assembly to the Rotary Frame.
10. Reaching in through the top of the printer, slide the Cyan Developer Assembly to the front of the printer to free the gears at the rear of the Developer Assembly.
11. Make sure you do not damage the Exit Actuator as you lift the front of the Cyan Developer Assembly to free the front of the Assembly from the front of the printer frame, and remove the Assembly.

### **Replacement**

1. Turn the Rotary Knob until you can access the Cyan Developer Assembly cavity through the top of the printer.  
There is a "C" molded into the rear of the Cyan Developer Assembly cavity.
2. Hold the Cyan Developer Assembly so the rear, or gear end, of the Assembly is slightly lower than the front.
3. Slide the rear of the Assembly into the locating pins located at the rear of the Cyan Developer Assembly.
4. Lower the front end of the Assembly making sure you do not damage the Exit Actuator.
5. Reposition the Cyan Developer Assembly until the Assembly seats firmly in the Rotary Frame and the screw hole at the front of the Assembly lines up with the screw hole at the front of the Rotary Frame.
6. Turn the Rotary Knob until the screw hole in the front of the Cyan Developer Assembly appears through the access hole a few inches above the Rotary Knob.
7. Use a large, shoulder screw to secure the Cyan Developer Assembly to the Rotary Frame.
8. Reinstall the Used Cartridge Sensor (RRP 9.70).
9. Reinstall the Rotary Latch to the front of the printer frame and use one screw to secure the Latch to the frame.
10. Reinstall the Inner Cover Assembly (RRP 9.2).
11. Reinstall the Top Cover Assembly (RRP 9.3).
12. Reinstall the Xerographic Cartridge (RRP 9.48).
13. Reinstall the Cyan Toner Cartridge (RRP 9.57).
14. Close the Front Cover.

## RRP 9.64 Cyan (C) Developer (PL7.1.33)

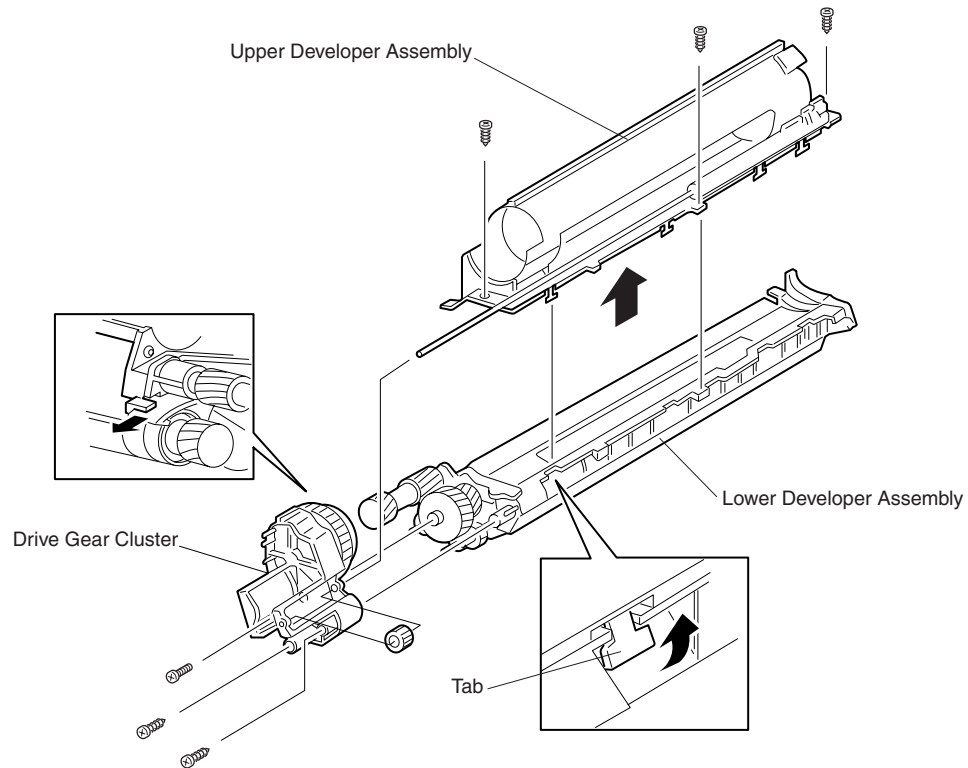

Figure 1

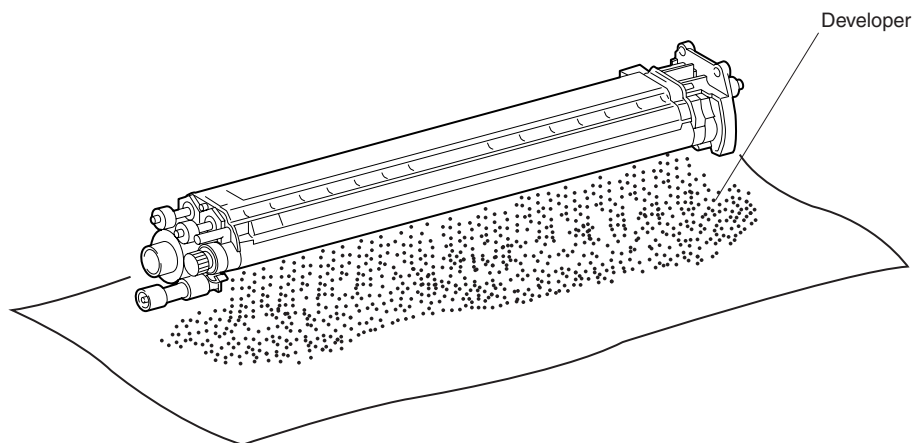

Figure 2

RS1061XB

RS1061XB

## RRP 9.64 Cyan (C) Developer (PL7.1.33)

---

### Removal

1. Remove the Cyan Developer Assembly (RRP 9.63).
2. Place the Cyan Developer Assembly, with the Magnet Roll down, on a flat and stable work surface.
3. Remove the three screws securing the Gear Cluster at the end of the Developer Assembly and remove the Cluster.
4. Remove the three screws securing the Upper Developer Assembly to the Lower Developer Assembly.
5. Gently release the four tabs that are located on one side of the Cyan Developer Assembly as you pry the Upper Developer Assembly off of the Lower Developer Assembly.
6. Turn the Developer Assembly upside down and pour the Developer onto a disposable towel or newspaper.
7. Discard the Developer according to company policy.



**Do not dispose of the Developer in an open fire.**

### Replacement

1. Pour Cyan Developer evenly along the Developer Assembly Auger.
2. Rotate the Auger Gear so the Auger turns and spreads the developer along the Assembly channel and Magnet Roll.
3. Reinstall the Upper Developer Assembly on top of the Lower Developer Assembly by first sliding the Dispense Shaft that is sticking out of one end of the Upper Assembly into the Auger Dispense Gear that is attached to the Lower Assembly.
4. Slide the two tabs that are located on the ends of the Upper Assembly under the two tabs that are located on the ends of the Lower Assembly, immediately above the Magnet Roll.
5. Seat the Upper Assembly onto the Lower Assembly so the three screw holes in the Upper Assembly line up with the three screw holes in the Lower Assembly.
6. Hook the four tabs that are on one side of the Upper Developer Assembly onto the four notches that are located on the Lower Developer Assembly.
7. Make sure the Upper Developer Assembly is seated firmly on top of the Lower Developer Assembly and that all tabs and latches are securely in place.
8. Use three screws to secure the Upper Developer Assembly to the Lower Developer Assembly.
9. Rotate the Developer Assembly gears so the Magnet Roll turns and the Developer forms an even brush on the Roll.
10. Reinstall the Cyan Developer Assembly (RRP 9.63).

## RRP 9.65 Black (K) Developer Assembly (PL7.1.40)

---

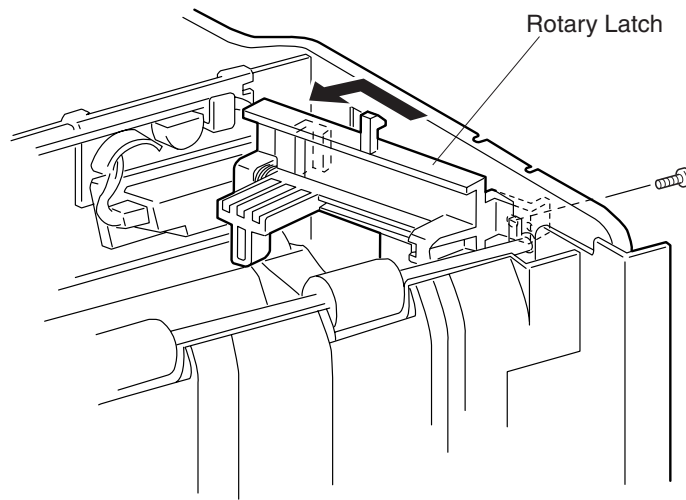

Figure 1

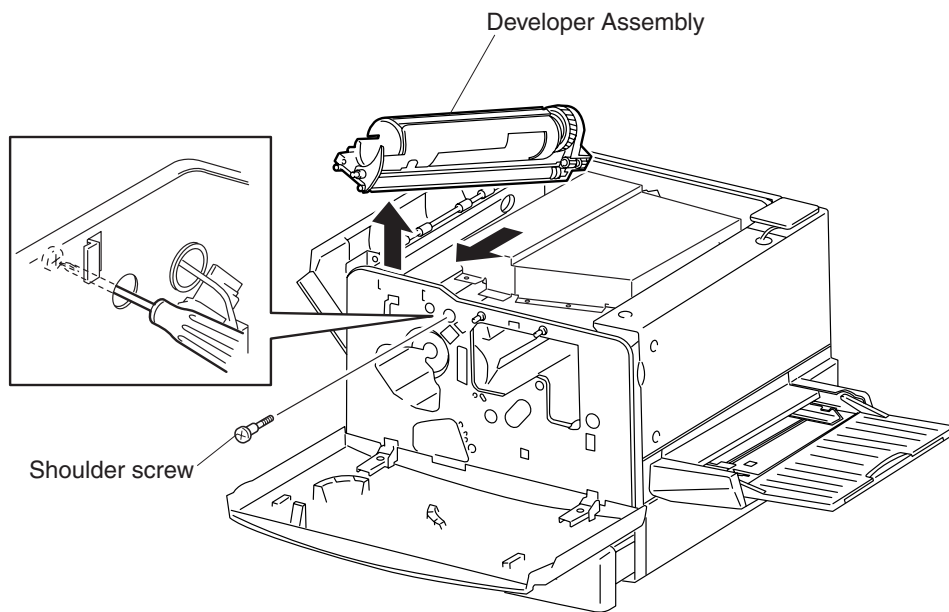

Figure 2

RS1060XB

RS1060XB

## **RRP 9.65 Black (K) Developer Assembly (PL7.1.40)**

---

### **Removal**

1. Open the Front Cover.
2. Remove the Black Toner Cartridge (RRP 9.58).
3. Remove the Xerographic Cartridge (RRP 9.48).
4. Remove the Top Cover Assembly (RRP 9.3).
5. Remove the Inner Cover Assembly (RRP 9.2).
6. Remove the Used Cartridge Sensor (RRP 9.70).
7. Remove the screw securing the Rotary Latch to the front of the printer frame and remove the Latch (Figure 1).
8. Turn the Rotary Knob until the large, shoulder screw securing the Black Developer Assembly to the Rotary Frame appears through the access hole a few inches above the Rotary Knob (Figure 2).
9. Remove the shoulder screw securing the Black Developer Assembly to the Rotary Frame.
10. Reaching in through the top of the printer, slide the Black Developer Assembly to the front of the printer to free the gears at the rear of the Developer Assembly.
11. Make sure you do not damage the Exit Actuator as you lift the front of the Black Developer Assembly to free the front of the Assembly from the front of the printer frame, and remove the Assembly.

### **Replacement**

1. Turn the Rotary Knob until you can access the Black Developer Assembly cavity through the top of the printer.  
There is a "K" molded into the rear of the Black Developer Assembly cavity.
2. Hold the Black Developer Assembly so the rear, or gear end, of the Assembly is slightly lower than the front.
3. Slide the rear of the Assembly into the locating pins located at the rear of the Black Developer Assembly.
4. Lower the front end of the Assembly making sure you do not damage the Exit Actuator.
5. Reposition the Black Developer Assembly until the Assembly seats firmly in the Rotary Frame and the screw hole at the front of the Assembly lines up with the screw hole at the front of the Rotary Frame.
6. Turn the Rotary Knob until the screw hole in the front of the Black Developer Assembly appears through the access hole a few inches above the Rotary Knob.
7. Use a large, shoulder screw to secure the Black Developer Assembly to the Rotary Frame.
8. Reinstall the Used Cartridge Sensor (RRP 9.70).
9. Reinstall the Rotary Latch to the front of the printer frame and use one screw to secure the Latch to the frame.
10. Reinstall the Inner Cover Assembly (RRP 9.2).
11. Reinstall the Top Cover Assembly (RRP 9.3).
12. Reinstall the Xerographic Cartridge (RRP 9.48).
13. Reinstall the Black Toner Cartridge (RRP 9.58).
14. Close the Front Cover.

## RRP 9.66 Black (K) Developer (PL7.1.43)

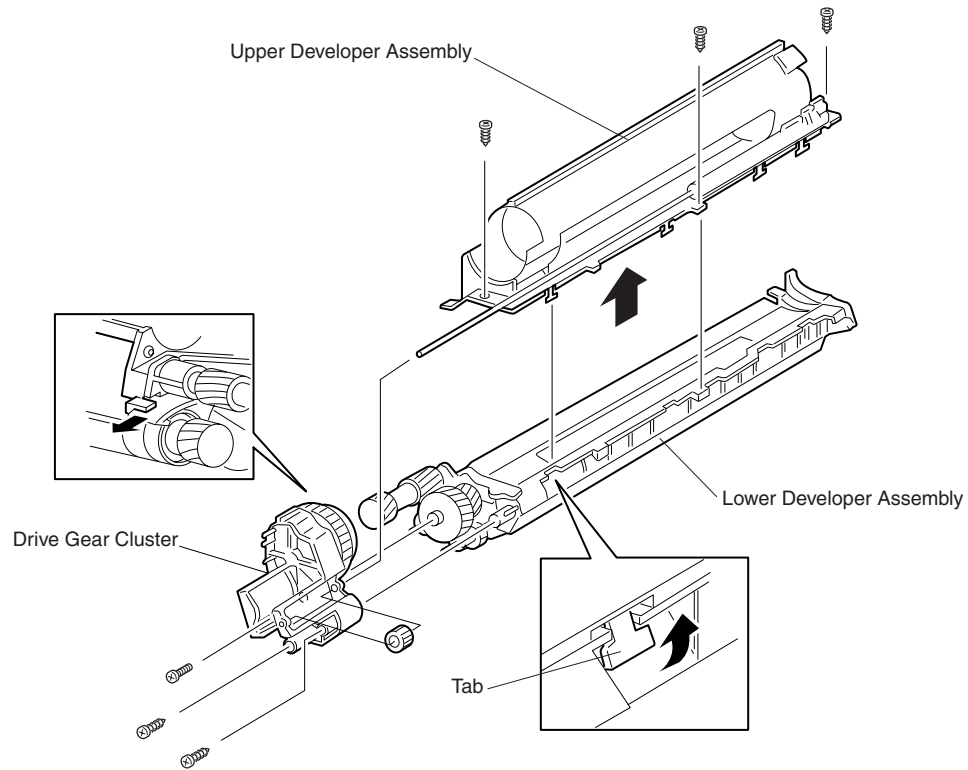

Figure 1

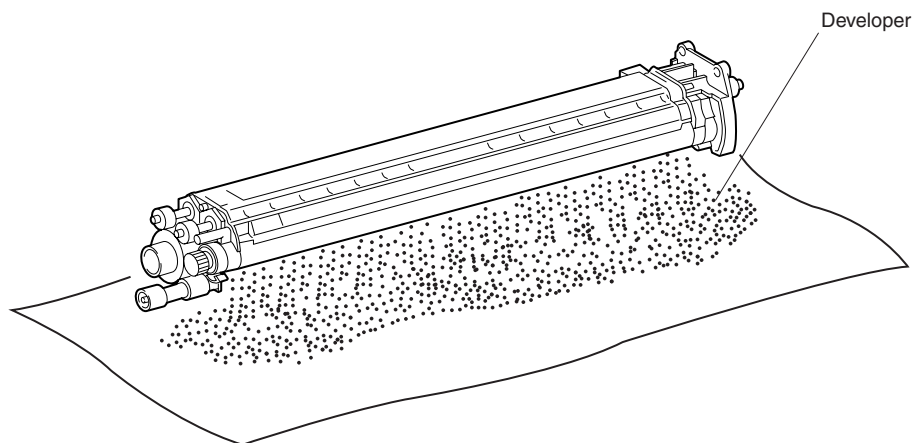

Figure 2

RS1061XB

RS1061XB



## RRP 9.66 Black (K) Developer (PL7.1.43)

---

### Removal

1. Remove the Black Developer Assembly (RRP 9.65).
2. Place the Black Developer Assembly, with the Magnet Roll down, on a flat and stable work surface.
3. Remove the three screws securing the Gear Cluster at the end of the Developer Assembly and remove the Cluster.
4. Remove the three screws securing the Upper Developer Assembly to the Lower Developer Assembly.
5. Gently release the four tabs that are located on one side of the Black Developer Assembly as you pry the Upper Developer Assembly off of the Lower Developer Assembly.
6. Turn the Developer Assembly upside down and pour the Developer onto a disposable towel or newspaper.
7. Discard the Developer according to company policy.



**Do not dispose of the Developer in an open fire.**

### Replacement

1. Pour Black Developer evenly along the Developer Assembly Auger.
2. Rotate the Auger Gear so the Auger turns and spreads the developer along the Assembly channel and Magnet Roll.
3. Reinstall the Upper Developer Assembly on top of the Lower Developer Assembly by first sliding the Dispense Shaft that is sticking out of one end of the Upper Assembly into the Auger Dispense Gear that is attached to the Lower Assembly.
4. Slide the two tabs that are located on the ends of the Upper Assembly under the two tabs that are located on the ends of the Lower Assembly, immediately above the Magnet Roll.
5. Seat the Upper Assembly onto the Lower Assembly so the three screw holes in the Upper Assembly line up with the three screw holes in the Lower Assembly.
6. Hook the four tabs that are on one side of the Upper Developer Assembly onto the four notches that are located on the Lower Developer Assembly.
7. Make sure the Upper Developer Assembly is seated firmly on top of the Lower Developer Assembly and that all tabs and latches are securely in place.
8. Use three screws to secure the Upper Developer Assembly to the Lower Developer Assembly.
9. Rotate the Developer Assembly gears so the Magnet Roll turns and the Developer forms an even brush on the Roll.
10. Reinstall the Black Developer Assembly (RRP 9.65).

## RRP 9.67 Rotary Frame Assembly (PL7.2.2)

---

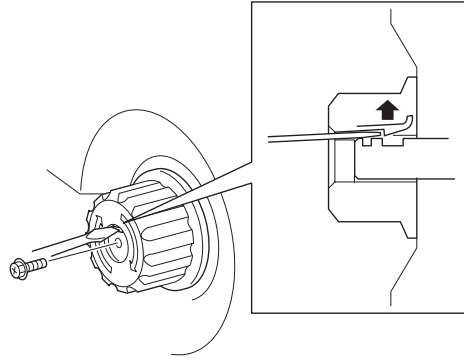

Figure 1

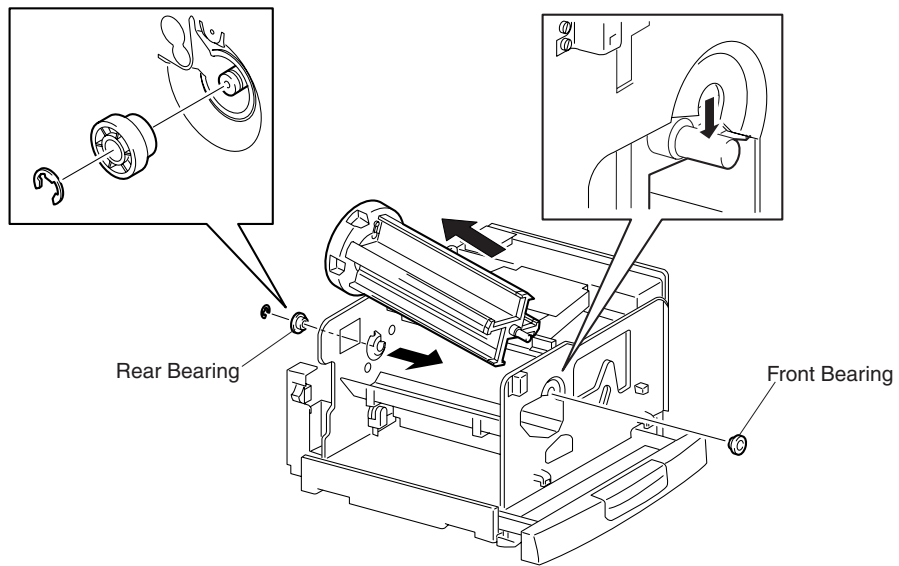

Figure 2

RS1062XB

RS1062XB

## RRP 9.67 Rotary Frame Assembly (PL7.2.2)

---

### Removal

1. Remove the Yellow Developer Assembly (RRP 9.59).
2. Remove the Magenta Developer Assembly (RRP 9.61).
3. Remove the Cyan Developer Assembly (RRP 9.63).
4. Remove the Black Developer Assembly (RRP 9.65).
5. If present, remove the screw securing the Rotary Knob the Rotary Shaft.
6. Release the Knob latch by inserting a screwdriver blade through the slot in the front of the Knob and pull the off of the Shaft (Figure 1).
7. Remove the Rotary Motor Assembly (RRP 9.114).
8. Remove the Dispense Motor Assembly (RRP 9.116).
9. Remove the Developer Clutch Assembly (RRP 9.117).
10. Remove the Developer Tie Plate (RRP 9.118).
11. Remove the Rotary Sensor (RRP 9.68).
12. Remove the large E ring securing the Rear Rotary Bearing to the rear of the printer frame and slide the Rear Bearing off of the Rotary Frame shaft (Figure 2).
13. Slide the Front Rotary Bearing off of the Rotary Frame shaft.
14. Slide the Rotary Frame Assembly to the front of the printer frame.
15. Pull the rear of the Rotary Frame Assembly free of the rear frame, swing the rear of the Assembly out of the printer and remove the Assembly.

### Replacement

1. Insert the Rotary Frame Assembly front shaft through the cutout in the front of the printer frame.
2. Swing the rear of the Rotary Frame Assembly into the printer and insert the Assembly rear shaft into the cutout in the rear of the printer frame.
3. Slide the Front Rotary Bearing, lip of Bearing facing out, onto the Rotary Frame shaft and into the cut-out in the front of the printer frame.
4. Slide the Rear Rotary Bearing, lip of Bearing facing out, onto the Rotary Frame shaft and into the cut-out in the rear of the printer frame.
5. Use a large E ring to secure the Rotary Frame shaft to the Rear Rotary Bearing to the frame.
6. Reinstall the Rotary Sensor (RRP 9.68).
7. Reinstall the Developer Tie Plate (RRP 9.118).
8. Reinstall the Developer Clutch Assembly (RRP 9.117).
9. Reinstall the Dispense Motor Assembly (RRP 9.116).
10. Reinstall the Rotary Motor Assembly (RRP 9.114).
11. Reinstall the Rotary Knob.
12. Reinstall the Black Developer Assembly (RRP 9.65).
13. Reinstall the Cyan Developer Assembly (RRP 9.63).
14. Reinstall the Magenta Developer Assembly (RRP 9.61).
15. Reinstall the Yellow Developer Assembly (RRP 9.59).

## RRP 9.68 Rotary Sensor (PL7.2.22)

---

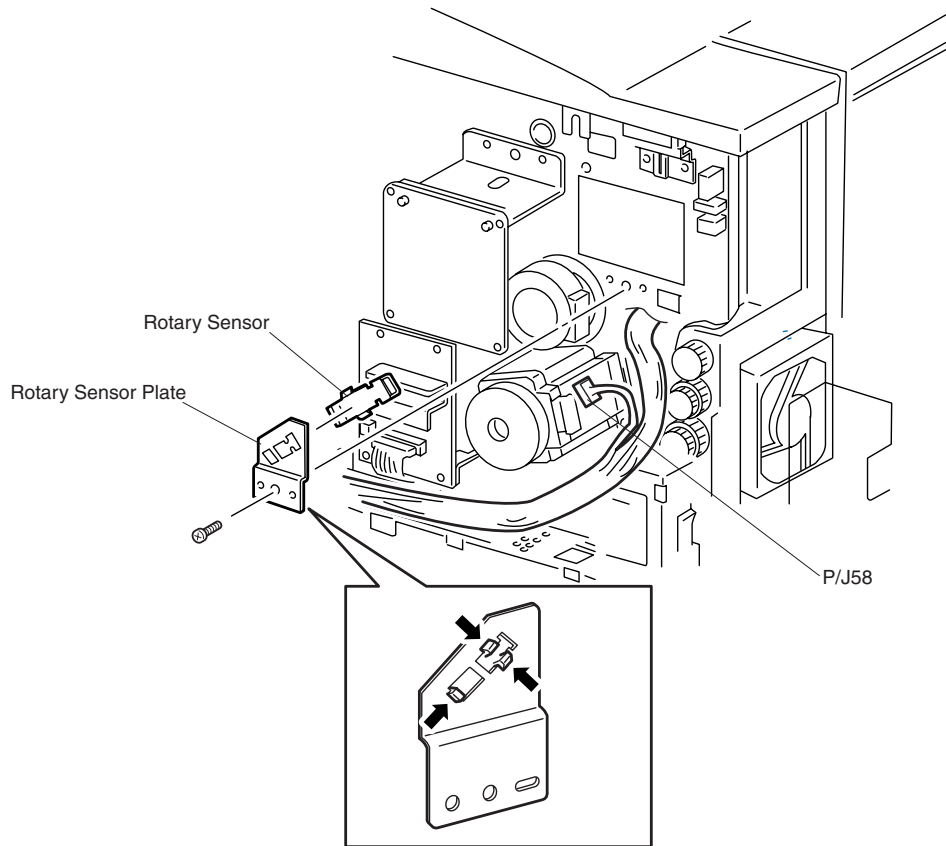

RS1063XB

RS1063XB

## **RRP 9.68 Rotary Sensor (PL7.2.22)**

---

### **Removal**

1. Remove the duct for Developer Fan by first removing the Fan (RRP 9.122) then removing the screw securing the duct to the printer frame and removing the duct.
2. Remove the screw securing the Rotary Sensor Plate to the printer frame and remove the Plate, along with the attached Rotary Sensor, from the frame.
3. Disconnect P/J 58 from the Rotary Sensor.
4. Squeeze the three latches securing the Sensor to the Plate and remove the Sensor.

### **Replacement**

1. Position the Rotary Sensor against the Rotary Sensor Plate.
2. Press the Sensor latches into the cutout in the Plate.  
The Sensor snaps into place.
3. Reconnect P/J 58 to the Rotary Sensor.
4. Position the Rotary Plate against the printer frame so the Rotary Sensor is facing into the cutout in the frame.
5. Realign the Plate so the screw hole and two positioning holes in the Plate line up with the screw hole and two positioning pins on the printer frame.
6. Use one screw to secure the Rotary Sensor Plate to the printer frame.
7. Reinstall the duct for the Developer Fan and use one screw to secure the duct to the printer frame.
8. Reinstall the Developer Fan (RRP 9.122).

## RRP 9.69 Cartridge Sensor (PL7.2.26)

---

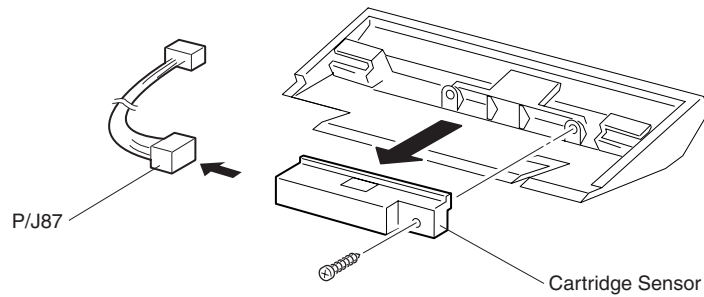
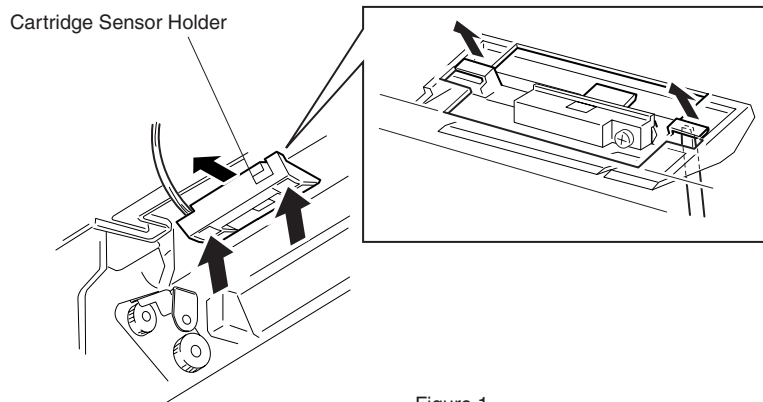

RS1064XB

RS1064XB

## **RRP 9.69 Cartridge Sensor (PL7.2.26)**

---

### **Removal**

1. Remove the Fuser Assembly (RRP 9.80).
2. Reach inside the empty Fuser cavity and slide the Cartridge Sensor Holder forward to unlatch the Holder from the printer frame (Figure 1).
3. Move the Holder around until the side latches on the Holder line up with the cutouts in the frame and the Holder is free of the frame.
4. Disconnect P/J 87 from the Cartridge Sensor.
5. Remove the screw securing the Cartridge Sensor to the Cartridge Sensor Holder and remove the Sensor (Figure 2).

### **Replacement**

1. Position the Cartridge Sensor onto the Sensor Holder so the LEDs face out.
2. Line up the position tab and screw hole on the Sensor with the two holes in the Holder.
3. Use one screw to secure the Cartridge Sensor to the Sensor Holder.
4. Reconnect P/J 87 to the Cartridge Sensor.
5. Position the Holder against the Holder cutout in the printer frame.
6. Move the Sensor wire harness so it exit through the cutout at the rear of the Holder.
7. Move the Holder around until the side latches on the Holder line up with the cutouts in the frame.
8. Push the Holder forward until the front latch secures the Holder to the frame.
9. Reinstall the Fuser Assembly (RRP 9.80).

## RRP 9.70 Used Cartridge Sensor (PL7.2.30)

---

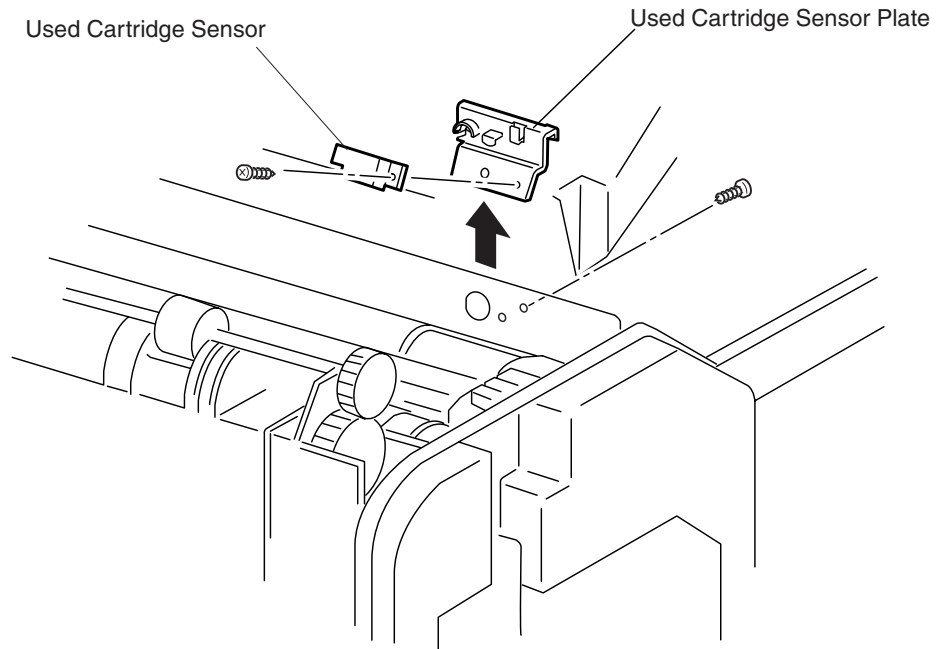

RS1065XB

RS1065XB



## **RRP 9.70 Used Cartridge Sensor (PL7.2.30)**

---

### **Removal**

1. Remove the Top Cover (RRP 9.3).
2. Remove the screw securing the Used Cartridge Sensor Plate to the printer frame and remove the Plate.
3. Disconnect P/J 88 from the Used Cartridge Sensor.
4. Remove the screw securing the Used Cartridge Sensor to the Used Cartridge Sensor Plate and remove the Sensor.

### **Replacement**

1. Position the Used Cartridge Sensor on the Sensor Plate so the screw holes line up.
2. Use one screw to secure the Sensor to the Plate.
3. Reconnect P/J 88 to the Used Cartridge Sensor.
4. Reinstall the Used Cartridge Sensor Plate to the printer frame and use one screw to secure the Plate.
5. Reinstall the Top Cover (RRP 9.3).

## RRP 9.71 Transfer Assembly (PL8.1.3)

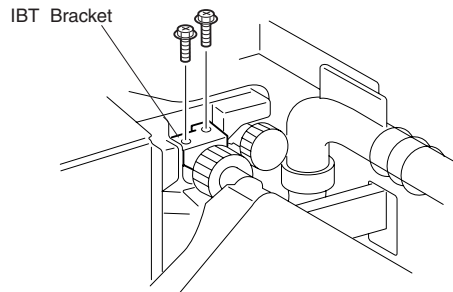

Figure 1

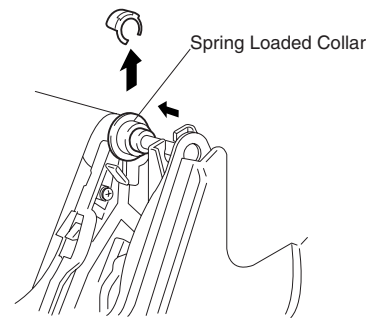

Figure 2

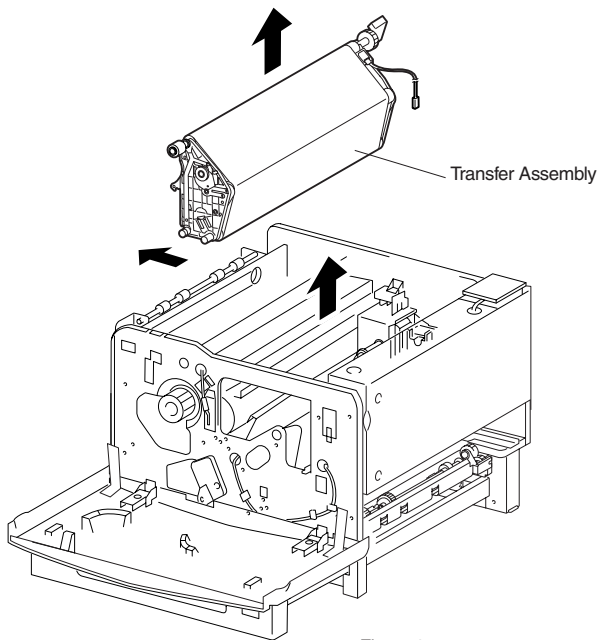

Figure 3

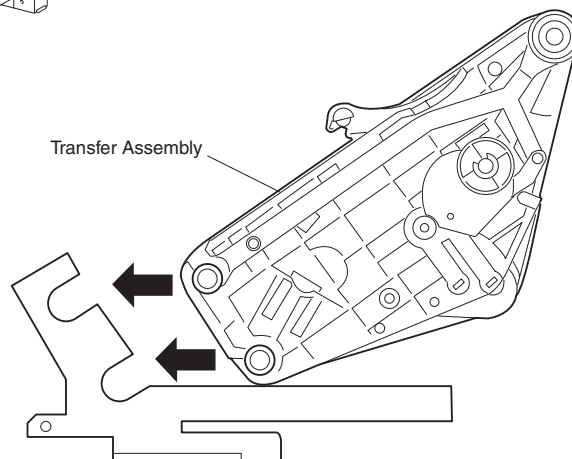

Figure 4

RS1066XB

RS1066XB

## RRP 9.71 Transfer Assembly (PL8.1.3)

---

### Removal

1. Remove the High Voltage Power Supply (RRP 9.120).
2. Remove the XL Rail Assembly (RRP 9.52).
3. Remove the Main Paper Handling Assembly (RRP 9.36).
4. Remove the ADC Sensor Assembly (RRP 9.50).
5. Disconnect P/J 57 from the TR0 Sensor.
6. Remove the two screws securing the IBT Bracket to the rear of the printer frame and remove the Bracket (Figure 1)



*The IBT is easily scratched. When removing the Transfer Assembly be extremely careful that you do not touch the surface of the IBT with your fingers or scrape the IBT against other components.*

*Do not remove the Transfer Assembly by pulling on the Push In Shaft.*

7. Hold on to the front and the rear of the IBT shaft.
8. Push in on the spring loaded collar to release the front of the IBT Drive Shaft from the front of the printer frame (Figure 2).
9. Lift the Transfer Assembly up, free the two HVPS wires from the grommet hole at the rear of the frame, and out of the printer frame (Figure 3).
10. Place the Transfer Assembly on a clean, flat, and stable work surface.

### Replacement

1. Hold on to the front and the rear of the IBT shaft.
2. Position the Transfer Assembly so the TR0 Sensor is at the rear of the printer.
3. Carefully lower the back of the Transfer Assembly into the printer frame, making sure the plastic rollers at the back of Assembly fit into place in the grooves in the printer frame (Figure 4).
4. Lower the front of the Transfer Assembly so the rear of the IBT Drive Shaft rests on the cast metal support at the rear of the printer.
5. Push in on the spring loaded collar and insert the front of the IBT Drive Shaft into the slot in the front of the printer frame.
6. Reinstall the IBT Bracket over the rear of the IBT Drive Shaft and use two screws to secure the Bracket to the printer frame.
7. Reconnect P/J 57 to the TR0 Sensor.
8. Reinstall the ADC Sensor Assembly (RRP 9.50).
9. Reinstall the Main Paper Handling Assembly (RRP 9.36).
10. Reinstall the XL Rail Assembly (RRP 9.52).
11. Reinstall the High Voltage Power Supply (RRP 9.120).

## RRP 9.72 Tension Lever (PL8.1.4)

---

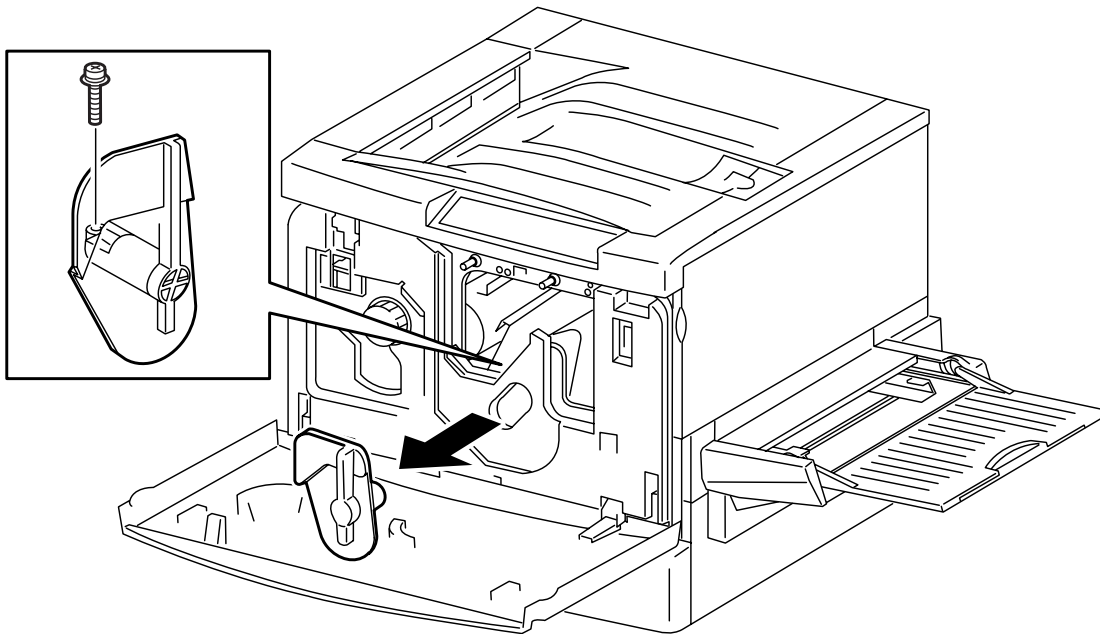

RS1067XB

RS1067XB

## **RRP 9.72 Tension Lever (PL8.1.4)**

---

### **Removal**

1. Remove the Xerographic Cartridge (RRP 9.48).
2. Rotate the Tension Lever clockwise.
3. Loosen the screw securing the Tension Lever to the IBT Push In Shaft.
4. Slide the Tension Lever off of the Shaft.

### **Replacement**

1. Rotate the Tension Lever slightly to find the flat spot on the IBT Push In Shaft, then push the Lever as far as it will go onto the Shaft.
2. Tighten the screw securing the Tension Lever to the IBT Push In Shaft.
3. Rotate the Tension Lever counter clockwise and clockwise to make sure the Lever is securely in place on the Shaft.
4. Reinstall the Xerographic Cartridge (RRP 9.48).

## RRP 9.73 2nd BTR Cam Assembly (PL8.1.10)

---

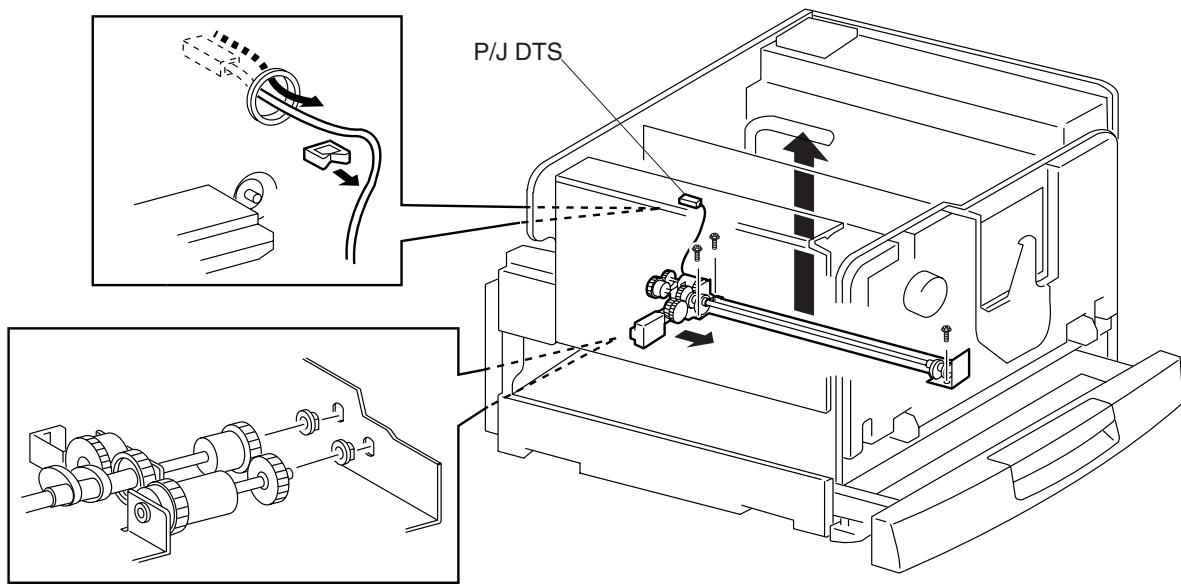

RS1068XB

RS1068XB

## RRP 9.73 2nd BTR Cam Assembly (PL8.1.10)

---

### Removal

1. Remove the 2nd BTR Assembly (RRP 9.75).
2. Remove the BTR Cam Solenoid (RRP 9.74).
3. Remove the Auger Assembly (RRP 9.77).
4. Remove the three screws securing the 2nd BTR Cam Assembly to the printer frame and pull the Assembly a few inches away from the rear frame.
5. Disconnect the DTS wire running to the BTR Cam Assembly.
6. Remove the 2nd BTR Cam Assembly.

### Replacement

1. Position the 2nd BTR Cam Assembly so the gears are near the opening in the rear of the printer frame.
2. Reconnect the DTS wire to the BTR Cam Assembly.
3. If necessary, reinstall the gear onto the end of the Torque Shaft.
4. Insert the Cam Assembly gears through the opening in the rear of the printer frame and insert the ends of the two shafts into the bearings in the BTR Side Bracket.
5. Line up the three screw holes in the Cam Assembly with the three screw holes in the floor of the printer frame.
6. Use three screws to secure the 2nd BTR Cam Assembly to the printer frame.
7. Reinstall the Auger Assembly (RRP 9.77).
8. Reinstall the BTR Cam Solenoid (RRP 9.74).

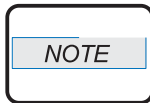

*Make sure the top edge of the BTR Cam Solenoid Bracket is mounted parallel with the top edge of the BTR Side Bracket. Image quality problems may result if the Solenoid Bracket is not parallel. Refer to the illustration in RRP 9.74.*

9. Reinstall the 2nd BTR Assembly (RRP 9.75).

## RRP 9.74 BTR Cam Solenoid (PL8.1.15)

---

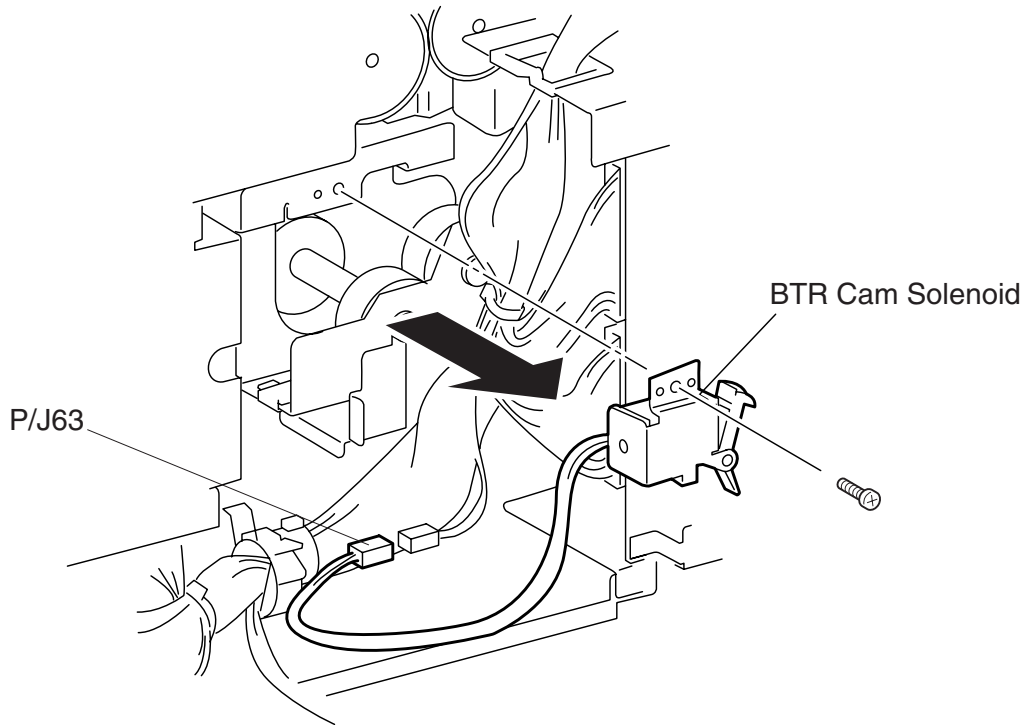

RS1069XB

RS1069XB



## RRP 9.74 BTR Cam Solenoid (PL8.1.15)

---

### Removal

1. Remove the High Voltage Power Supply (RRP 9.120).
2. Remove the screw securing the BTR Cam Solenoid to the BTR Side Bracket and remove the Solenoid.
3. Disconnect P/J 63 from the BTR Cam Solenoid.

### Replacement

1. Reinstall the BTR Cam Solenoid onto the BTR Side Bracket.
2. Line up with positioning hole and screw hole on the Solenoid with the positioning tab and screw hole on the Side Bracket.

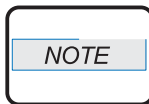

*Make sure the top edge of the BTR Cam Solenoid Bracket is mounted parallel with the top edge of the BTR Side Bracket. Image quality problems may result if the Solenoid Bracket is not parallel.*

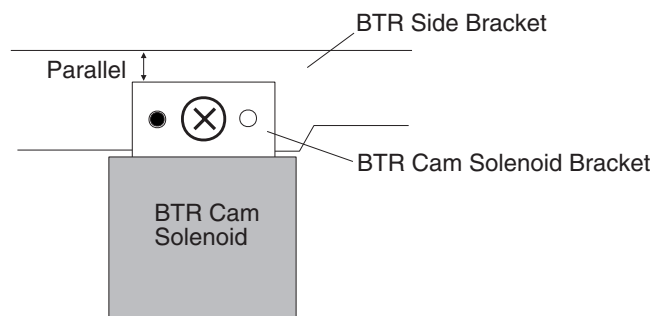

RS2027X

3. Use one screw to secure the BTR Cam Solenoid to the BTR Side Bracket.
4. Reconnect P/J 63 to the BTR Cam Solenoid.
5. Reinstall the High Voltage Power Supply (RRP 9.120).

## RRP 9.75 2nd BTR Assembly (PL8.1.20)

---

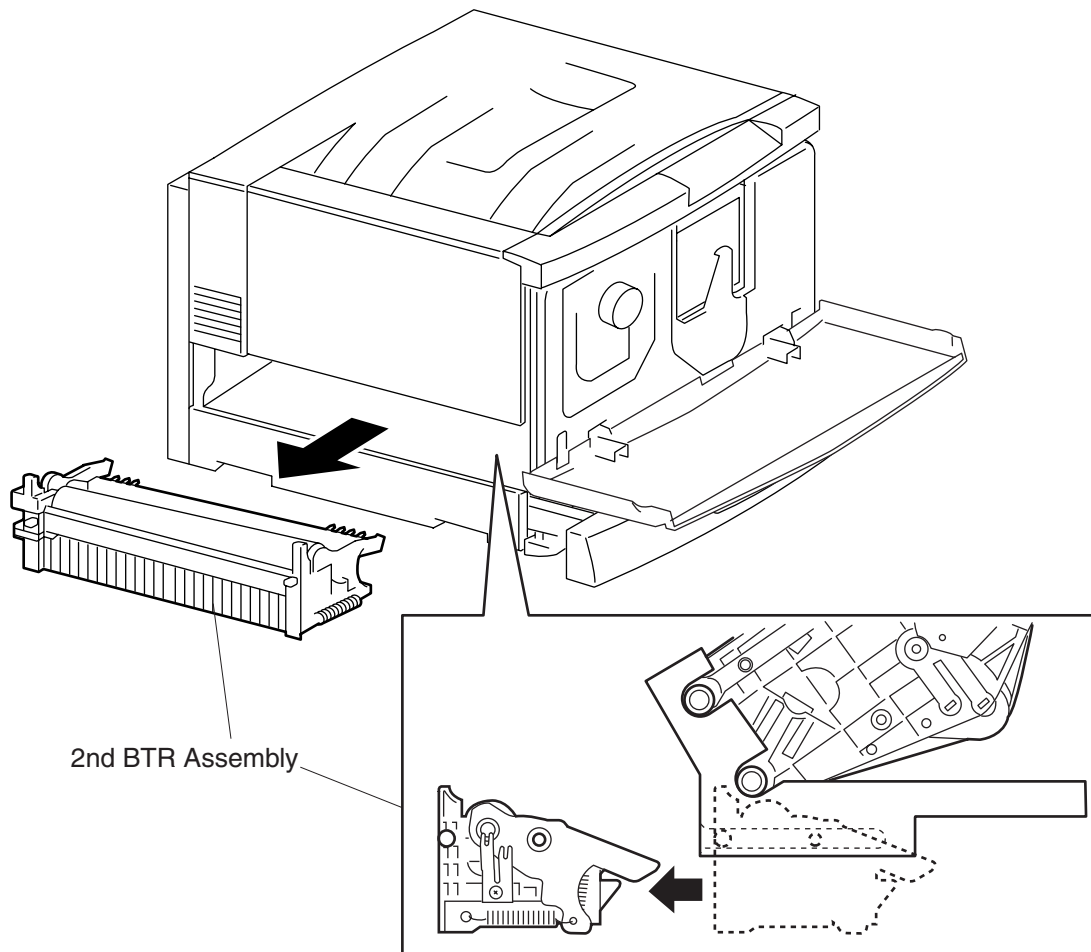

RS1070XB

RS1070XB

## **RRP 9.75 2nd BTR Assembly (PL8.1.20)**

---

### **Removal**

1. Remove the Transfer Assembly (RRP 9.71).
2. Remove the Belt Cleaner Assembly (RRP 9.76).
3. Reach through the empty Fuser Assembly cavity and slide the 2nd BTR Assembly out of the IBT Front and Rear Brackets and out of the printer.

### **Replacement**

1. Position the 2nd BTR so the gears face the rear of the printer and place the 2nd BTR Assembly on the frame inside the empty Fuser cavity.
2. Place your left hand on the rear of the 2nd BTR and place your right hand on the front of the 2nd BTR and push the 2nd BTR into the slots in the IBT Front and Rear Brackets.
3. Push hard on both ends to make sure the 2nd BTR has seated correctly.
4. Reinstall the Belt Cleaner Assembly (RRP 9.76).
5. Reinstall the Transfer Assembly (RRP 9.71).
6. Refer to Section 9 of this manual and reset the 2nd BTR Assembly Life Counter to zero.

## RRP 9.76 Belt Cleaner Assembly (PL8.1.30)

---

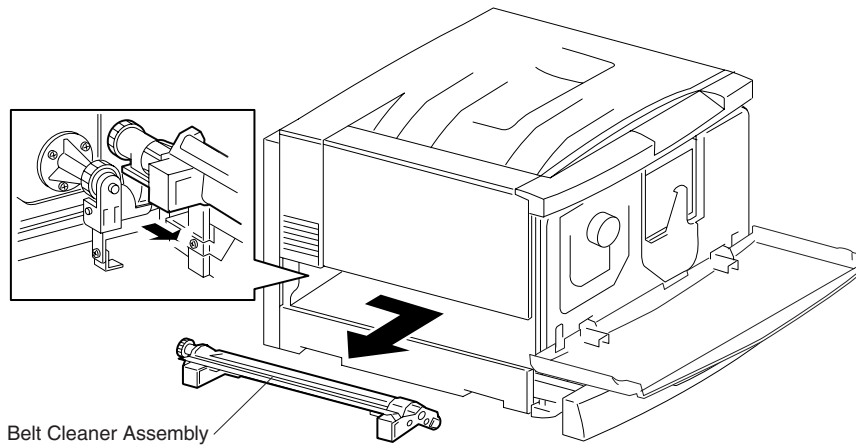
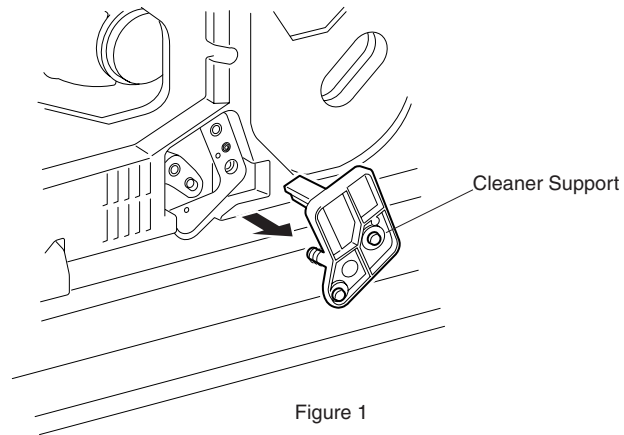

RS1071XB

RS1071XB

## **RRP 9.76 Belt Cleaner Assembly (PL8.1.30)**

---

### **Removal**

1. Remove the Fuser Assembly (RRP 9.80).
2. Open the Front Cover.
3. Reach in through the empty Fuser Assembly cavity and hold the bottom of the Belt Cleaner Assembly.
4. Loosen the two screws securing the Cleaner Support to the printer frame and remove the Cleaner Support (Figure 1).
5. Slide the Belt Cleaner Assembly to the front of the printer and remove the Assembly through the Fuser cavity (Figure 2).

### **Replacement**

1. Reinstall the Belt Cleaner Assembly through the empty Fuser cavity.
2. Line up the mark on positioning pin at the rear of the Assembly with the mark on the positioning hole at the rear of the printer and slide the pin into the hole.
3. Line up the two screws attached to the Cleaner Support with the screw holes in the printer frame.
4. Line up the front of the Belt Cleaner Assembly with the spring and support bar sticking out from the Cleaner Support.
5. Tighten the two screws attached to the Cleaner Support to secure the Support and the Belt Cleaner Assembly to the printer frame.
6. Reach in through the Fuser cavity and raise and release the Belt Cleaner Assembly to make sure the Assembly moves freely.
7. Reinstall the Fuser Assembly (RRP 9.80).
8. Refer to Section 9 of this manual and reset the Belt Cleaner Assembly Life Counter to zero.

## RRP 9.77 Auger Assembly (PL8.1.40)

---

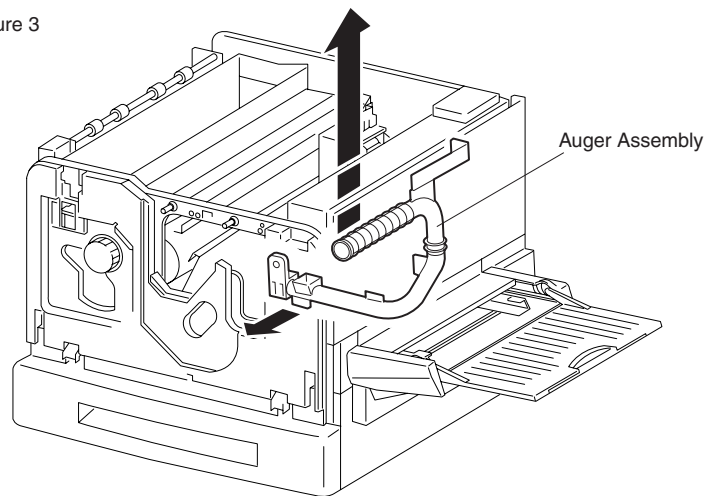
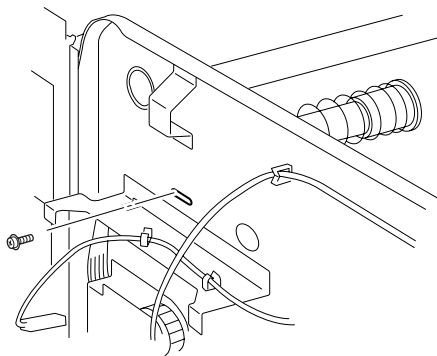
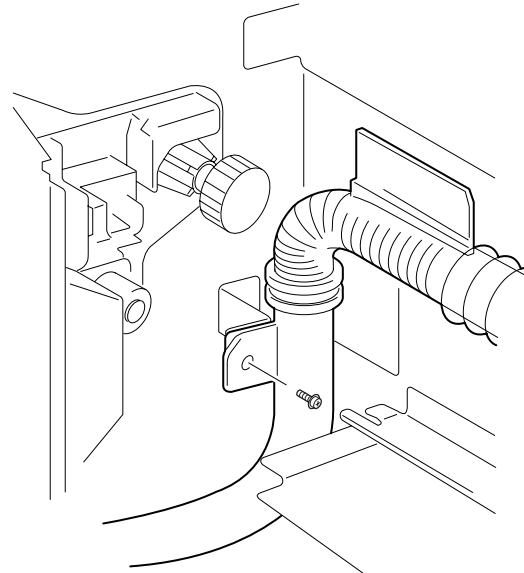
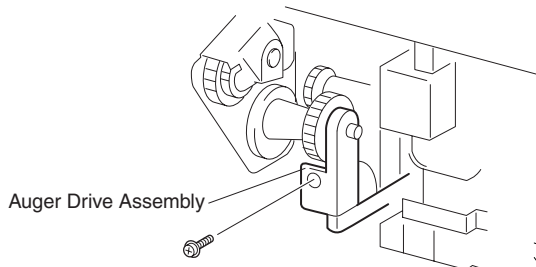

RS1072XB

RS1072XB

## **RRP 9.77 Auger Assembly (PL8.1.40)**

---

### **Removal**

1. Remove the Transfer Assembly (RRP 9.71).
2. Remove 2nd BTR Assembly (RRP 9.75).
3. Remove the Fuser Drive Assembly (RRP 9.110).
4. Remove the two screws securing the IBT Rear Bracket to the rear of the printer frame and remove the Bracket.
5. Remove the screw securing the Auger Drive Assembly to the printer frame (Figure 1).
6. Remove the screw securing the Auger Tube to the rear of the printer frame (Figure 2).
7. Remove the screw securing the Auger Assembly bracket to the rear of the printer frame (Figure 3).
8. Swing the bottom of the Auger Assembly out, then slide the Auger Assembly down and remove the Assembly from the printer (Figure 4).

### **Replacement**

1. Reinstall the Auger Assembly onto the printer (Figure 4).
2. Slide the Auger Assembly bracket into position at the rear of the printer frame and use one screw to secure the bracket.
3. Use one screw to secure the Auger Tube to the rear of the printer frame.
4. Use one screw to secure the Auger Drive Assembly to the printer frame.
5. Reinstall the IBT Rear Bracket to the rear of the printer frame and use two screws to secure the Bracket.
6. Reinstall the Fuser Drive Assembly (RRP 9.110).
7. Reinstall the 2nd BTR Assembly (RRP 9.75).
8. Reinstall the Transfer Assembly (RRP 9.71).

## RRP 9.78 IBT Belt Assembly (PL8.2.2)

---

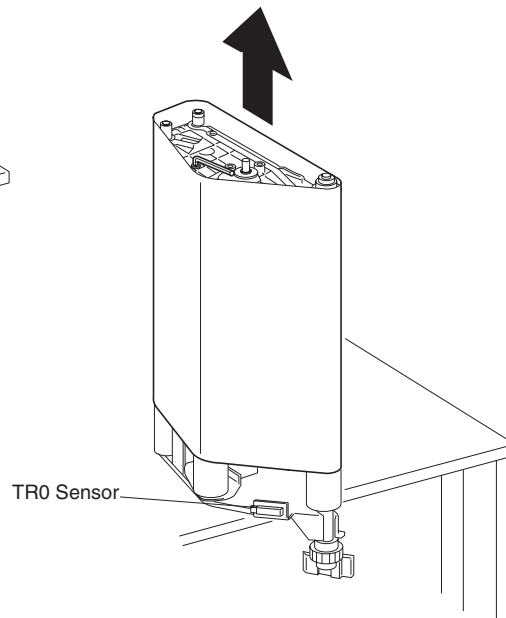
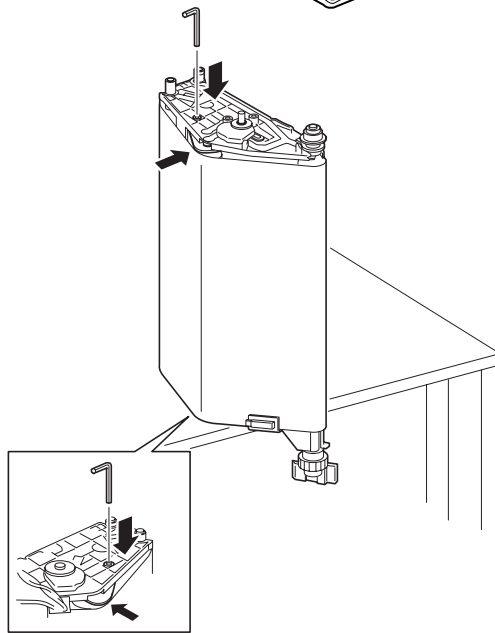
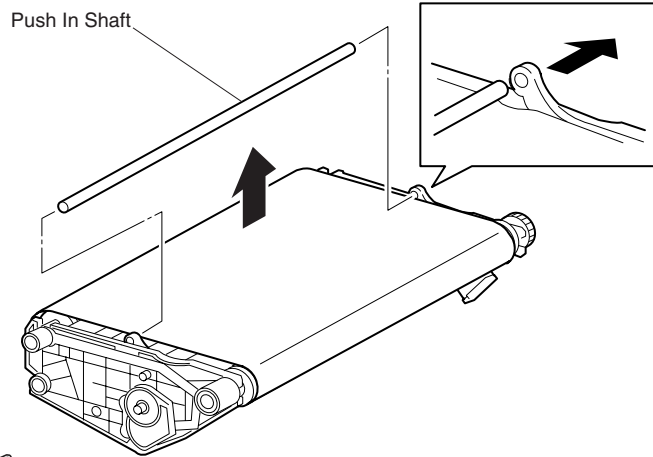

RS1073XB

RS1073XB



## RRP 9.78 IBT Belt Assembly (PL8.2.2)

---

### Removal

1. Remove the Transfer Assembly (RRP 9.71).



*The IBT is easily scratched. When removing the Transfer Assembly be extremely careful that you do not touch the surface of the IBT with your fingers or scrape the IBT against other components.*

2. Place the Transfer Assembly on a clean, flat, and stable work surface.
3. Rotate the cams that are located on both sides of the Transfer Assembly and raise the Push In Shaft off of the IBT Belt.
4. Remove the Push In Shaft from the Shaft arms (Figure 1).
5. Push down on the front of the Middle Drive Roll until the screw hole on the Roll arm (inside the Transfer Assembly) lines up with the screw hole on the front of the Transfer Assembly (Figure 2).
6. Insert a long screw or allen wrench through the two holes to lock the front of the Middle Drive Roll in place.
7. Push down on the rear of the Middle Roll until the screw hole on the Roll arm (inside the Transfer Assembly) lines up with the screw hole on the rear of the Transfer Assembly.
8. Insert a long screw or allen wrench through the two holes to lock the rear of the Middle Drive Roll in place.
9. Place the Transfer Assembly on edge, with the TR0 Sensor at the bottom.
10. Hold on to the edge of the Belt and rotate the Belt as you slowly pull it off of the Assembly (Figure 3).

### Replacement

1. Position the IBT Belt Assembly so that when the Belt is reinstalled onto the Transfer Assembly, the two edge marks are on the same side as the TR0 Sensor.
2. Carefully rotate and slide the Belt onto the Transfer Assembly.
3. Continue sliding the Belt onto the Transfer Assembly until the edge marks are under the TR0 Sensor.
4. Remove the two long screws or allen wrenches that are locking the Middle Drive Roll in place.
5. Raise the Shaft arms above the Belt and reinstall the Push In Shaft into the ends of the Shaft arms.
6. Reinstall the Transfer Assembly (RRP 9.71).

## RRP 9.79 TR0 Sensor (PL8.2.12)

---

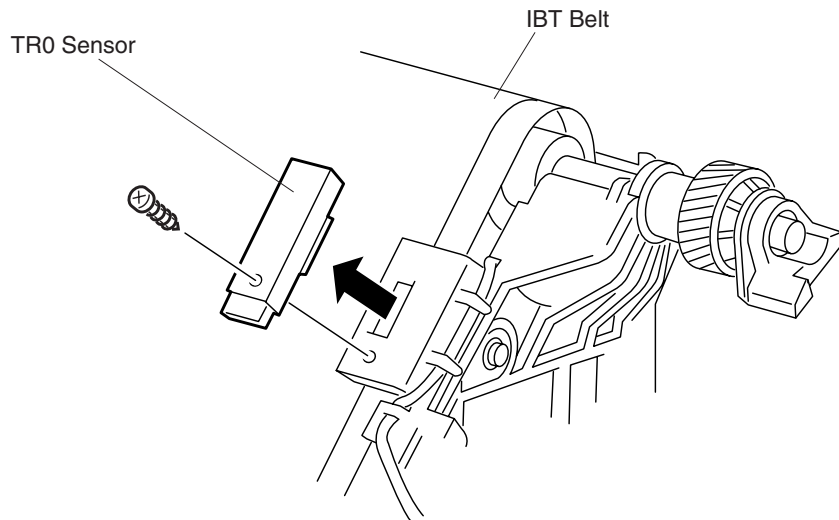

RS1074XC

RS1074XC

## **RRP 9.79 TR0 Sensor (PL8.2.12)**

---

### **Removal**

1. Remove the Transfer Assembly (RRP 9.71).
2. Disconnect the P/J from the TR0 Sensor.
3. Remove the screw securing the TR0 Sensor to the IBT frame and remove the Sensor.

### **Replacement**

1. Insert the LEDs of the TR0 Sensor through the slot in the IBT frame.
2. Use one screw to secure the TR0 Sensor to the IBT frame.
3. Reconnect the P/J to the TR0 Sensor.
4. Reinstall the Transfer Assembly (RRP 9.71).

## RRP 9.80 Fuser Assembly (PL9.1.1)

---

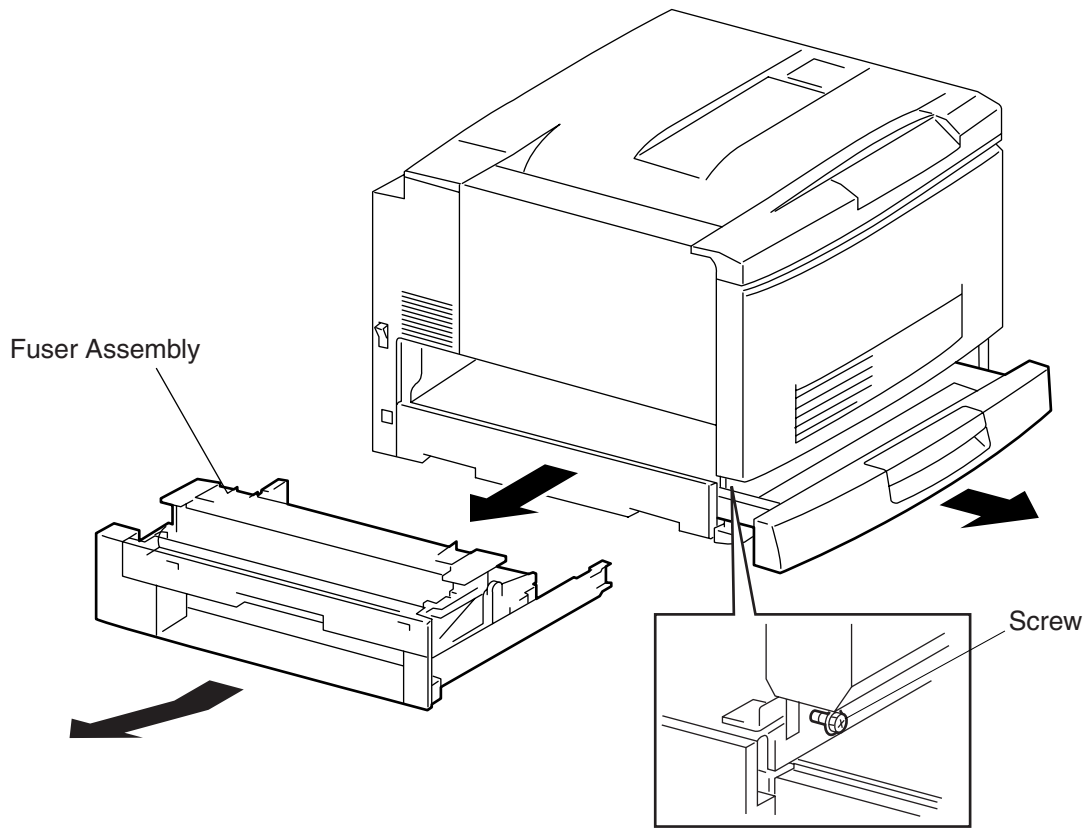

RS1075XC

RS1075XC

## **RRP 9.80 Fuser Assembly (PL9.1.1)**

---

### **Removal**

1. Slide Tray 1 a few inches out of the printer so you can access the screw that prevents the Fuser Assembly from sliding out of the printer.
2. Remove the screw securing the Fuser Assembly to the printer frame.
3. Slide the Fuser Assembly a few inches out of the printer.
4. Lift the end of the Fuser Assembly and pull the Assembly out of the printer.

### **Replacement**

1. Lift the end of the Fuser Assembly as you insert the Assembly side rails into the guide wheels inside the printer.
2. Lower the end of the Fuser Assembly and slide the Assembly into the printer.
3. Slide Tray 1 a few inches out of the printer.
4. Reinstall the screw to secure the Fuser Assembly to the printer frame.

## RRP 9.81 Main Fuser Assembly (PL9.1.2)

---

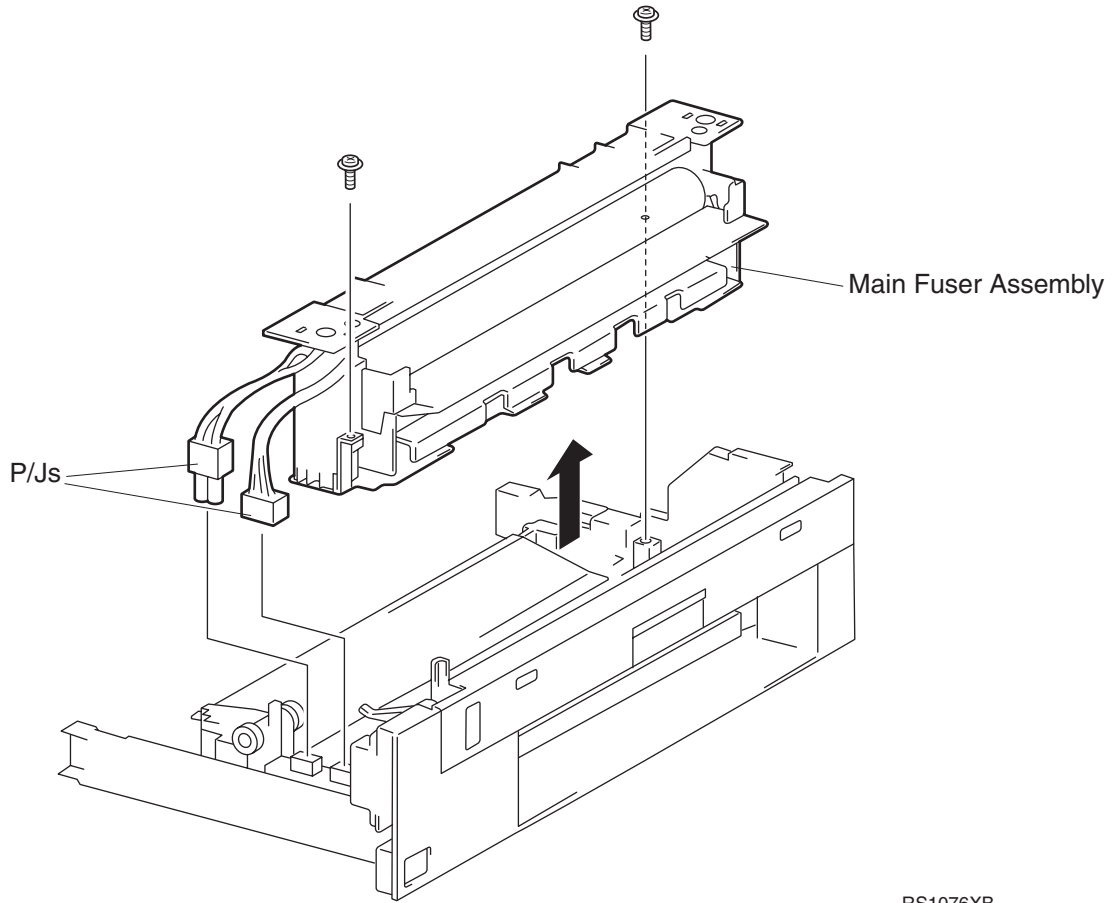

RS1076XB

RS1076XB

## **RRP 9.81 Main Fuser Assembly (PL9.1.2)**

---

### **Removal**

1. Remove the Oil Roll Assembly (RRP 9.82).
2. Disconnect the P/Js that are located at the end of the Main Fuser Assembly.
3. Remove the two screws securing the Main Fuser Assembly to the Fuser Tray and lift the Assembly up and out of the Tray.
4. Place the Main Fuser Assembly on a flat and stable work surface.

### **Replacement**

1. Lower the Main Fuser Assembly onto the Fuser Tray.
2. User two screws to secure the Main Fuser Assembly to the Fuser Tray.
3. Reconnect the two P/Js that are located at the end of the Main Fuser Assembly.
4. Reinstall the Oil Roll Assembly (RRP 9.82).
5. Refer to Section 9 of this manual and reset to zero the two Life Counters for the Main Fuser Assembly.

## RRP 9.82 Oil Roll Assembly (PL9.1.10)

---

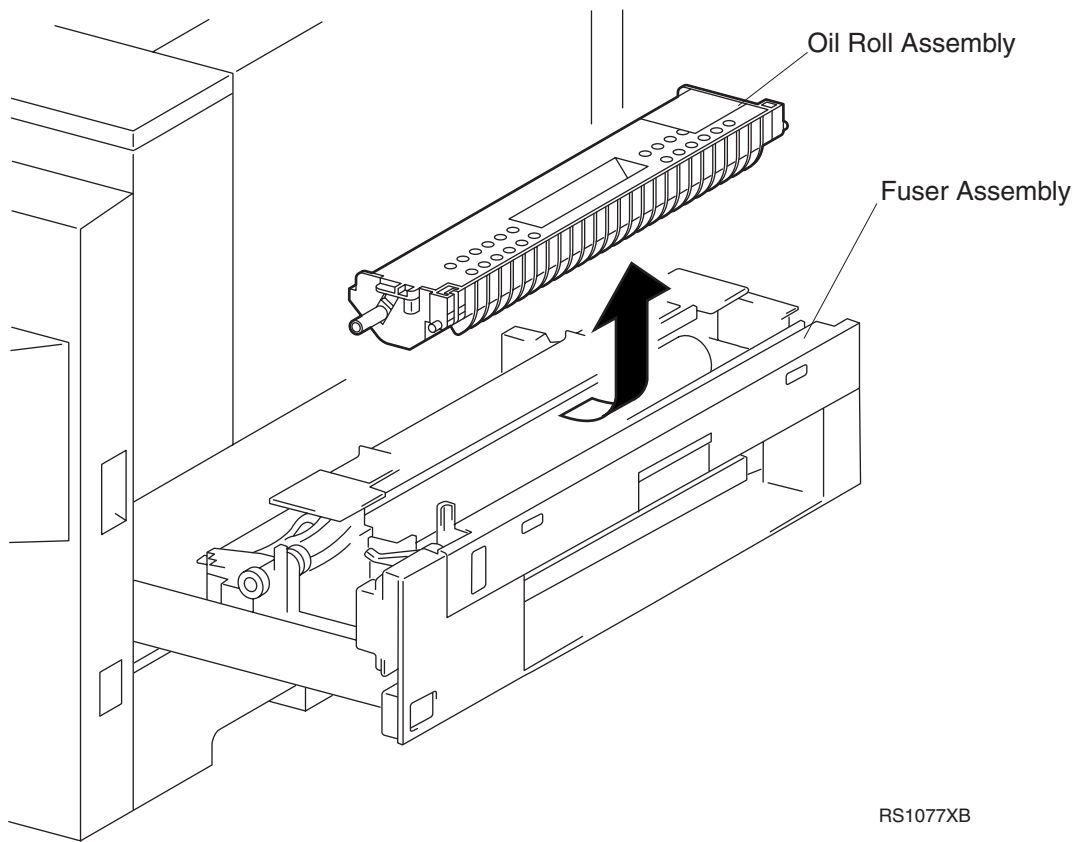

RS1077XB



## **RRP 9.82 Oil Roll Assembly (PL9.1.10)**

---

### **Removal**

1. Slide the Fuser Assembly out of the printer.
2. Hold onto the recessed handle and lift the Oil Roll Assembly out of the Fuser Assembly.

### **Replacement**

1. Slide the Fuser Assembly out of the printer.
2. Hold onto the recessed handle and lower the Oil Roll Assembly into the Fuser Assembly.
3. Press on the Oil Roll Assembly until it snaps into place.
4. Slide the Fuser Assembly into the printer.

## RRP 9.83 Pressure Roll (PL9.2.9)

---

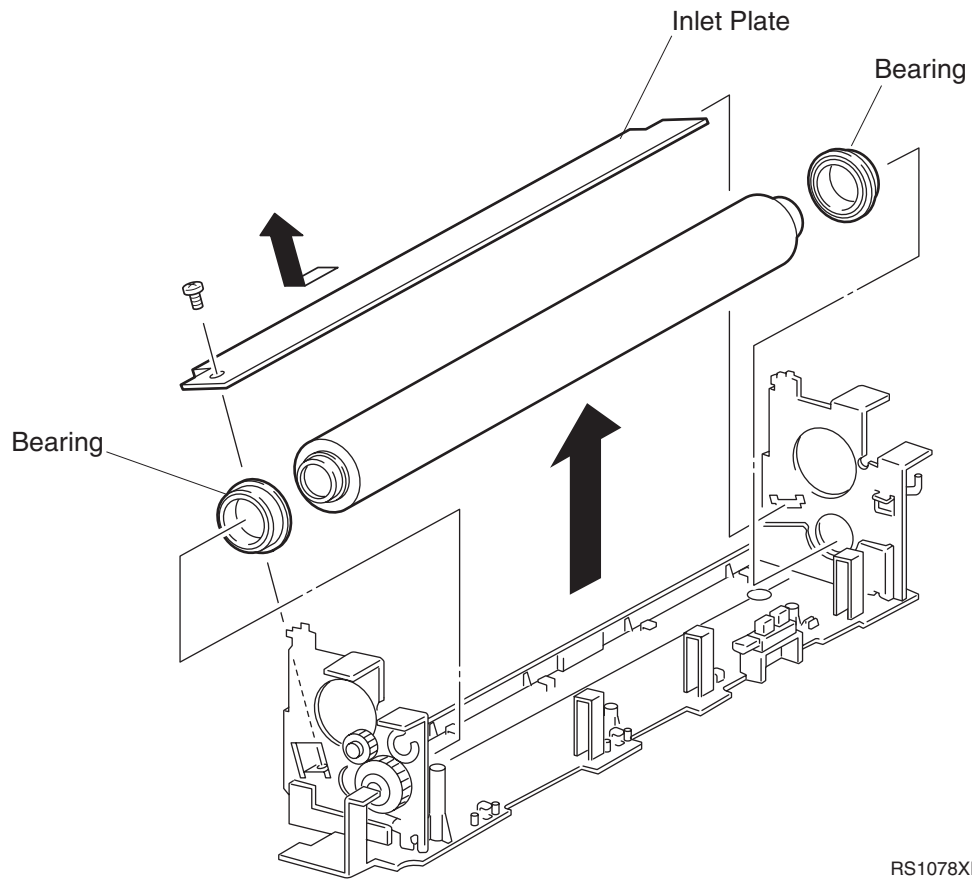

RS1078XB

RS1078XB

## **RRP 9.83 Pressure Roll (PL9.2.9)**

---

### **Removal**

1. Remove the Heat Roll Heat Rod (RRP 9.86).
2. Remove the Heat Roll (RRP 9.84).
3. Remove the Lower Guide Assembly (RRP 9.99).
4. Remove the screw securing the Fuser Inlet Plate to the Main Fuser Assembly and remove the Plate.
5. Lift the Pressure Roll front and rear bearings off of the front and rear Fuser Brackets and remove the Pressure Roll.

### **Replacement**

1. Reinstall the Pressure onto the Main Fuser Assembly so the front and rear bearings rest on the front and rear Fuser Brackets.  
The bearing rings should rest on the inside of the Fuser Brackets.
2. Reinstall the Fuser Inlet Plate to the Main Fuser Assembly and use one screw to secure the Plate to the Assembly.
3. Reinstall the Lower Guide Assembly (RRP 9.99).
4. Reinstall the Heat Roll (RRP 9.84).
5. Reinstall the Heat Roll Heat Rod (RRP 9.86).

## RRP 9.84 Heat Roll (PL9.2.12)

---

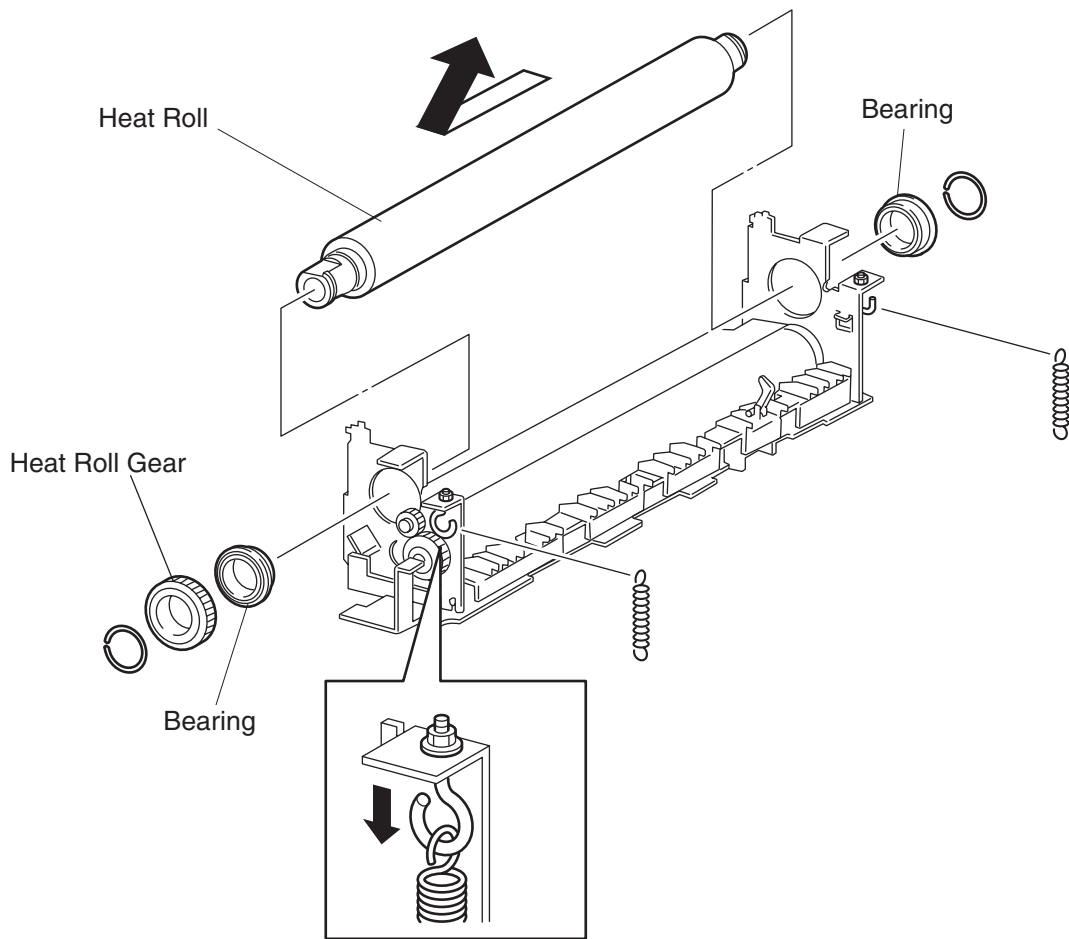

RS1079XB

RS1079XB

## RRP 9.84 Heat Roll (PL9.2.12)

---

### Removal

1. Remove the Heat Roll Heat Rod (RRP 9.86).
2. Remove the small ring that is attached to the rear end of the Heat Roll shaft.
3. Slide the Heat Roll Gear off of the rear of the Heat Roll shaft.
4. Remove the large ring that is attached to the rear Heat Roll bearing.
5. Slide the rear Heat Roll bearing off of the Heat Roll.
6. Remove the small ring that is attached to the front end of the Heat Roll shaft.
7. Remove the large ring that is attached to the front Heat Roll bearing.
8. Slide the front Heat Roll bearing off of the Heat Roll.
9. Remove the Heat Roll from the Main Fuser Assembly.

### Replacement

1. Position the Heat Roll so the long end is toward the rear of the Main Fuser Assembly.
2. Insert the rear and the front ends of the Heat Roll into the holes in the Main Fuser Assembly.
3. Position the front Heat Roll bearing so the ring groove is on the outside and slide the bearing over the front end of the Heat Roll.
4. Push down on the Heat Roll and press the bearing into the hole in the front of the Main Fuser Assembly.
5. Reinstall a large ring into the groove in the front bearing.
6. Reinstall a small ring into the groove at the front end of the Heat Roll shaft.
7. Position the rear Heat Roll bearing so the ring groove is on the outside and slide the bearing over the rear end of the Heat Roll.
8. Push down on the Heat Roll and press the bearing into the hole in the rear of the Main Fuser Assembly.
9. Reinstall a large ring into the groove in the rear bearing.
10. Slide the Heat Roll Gear onto the end of the Heat Roll shaft
11. Reinstall a small ring into the groove at the rear end of the Heat Roll shaft to secure the Gear to the shaft.
12. Reinstall the Heat Roll Heat Rod (RRP 9.86).

## RRP 9.85 Pressure Roll Heat Rod (PL9.2.19)

---

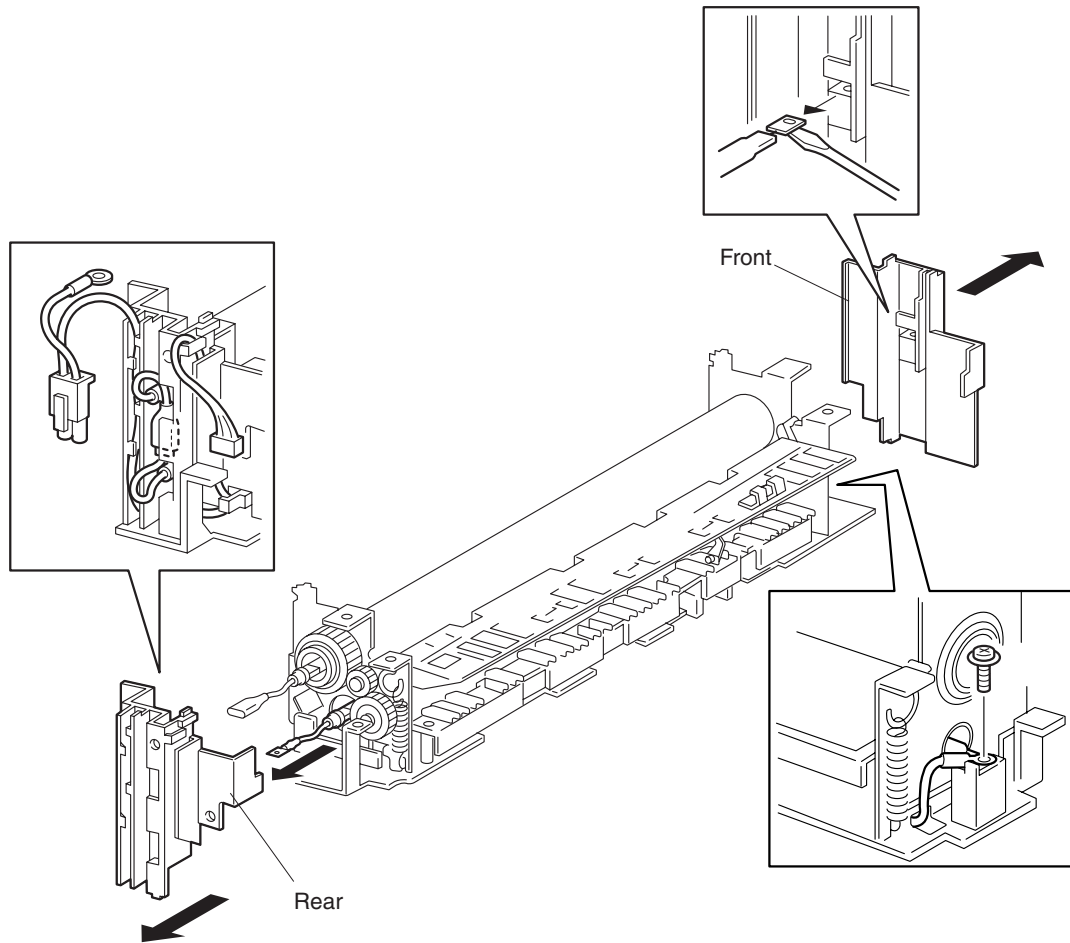

RS1080XB

RS1080XB

## RRP 9.85 Pressure Roll Heat Rod (PL9.2.19)

---

### Removal

1. Remove the Upper Fuser Assembly (RRP 9.87).
2. Remove the shrink tubing that is covering the connectors linking the Pressure Roll Heat Rod and the Heat Roll Heat Rod.
3. Push out on the connector latch and disconnect the two Rods from each other.
4. Free the rear of Pressure Roll Heat Rod from the Fuser Rear Cover.
5. Slide the Pressure Roll Heat Rod out of the Pressure Roll.

### Replacement



*Handle the Heat Rod by the ceramic end tips. If you accidentally touch the glass tube, wipe the it clean with a soft, dry cloth.*

1. Carefully insert the flat end of the Heat Rod into the rear of the Pressure Roll and push the Rod until the flat end exits the front of the Pressure Roll
2. Insert the rear of the Pressure Roll Heat Rod and the rear of the Heat Roll Heat Rod through the cut-outs in the Rear Fuser Cover.
3. Reconnect the Pressure Roll Heat Rod to the Heat Roll Heat Rod.
4. Reinstall a new piece of shrink tubing over the connection.
5. Reinstall the Upper Fuser Assembly (RRP 9.87).

## RRP 9.86 Heat Roll Heat Rod (PL9.2.20)

---

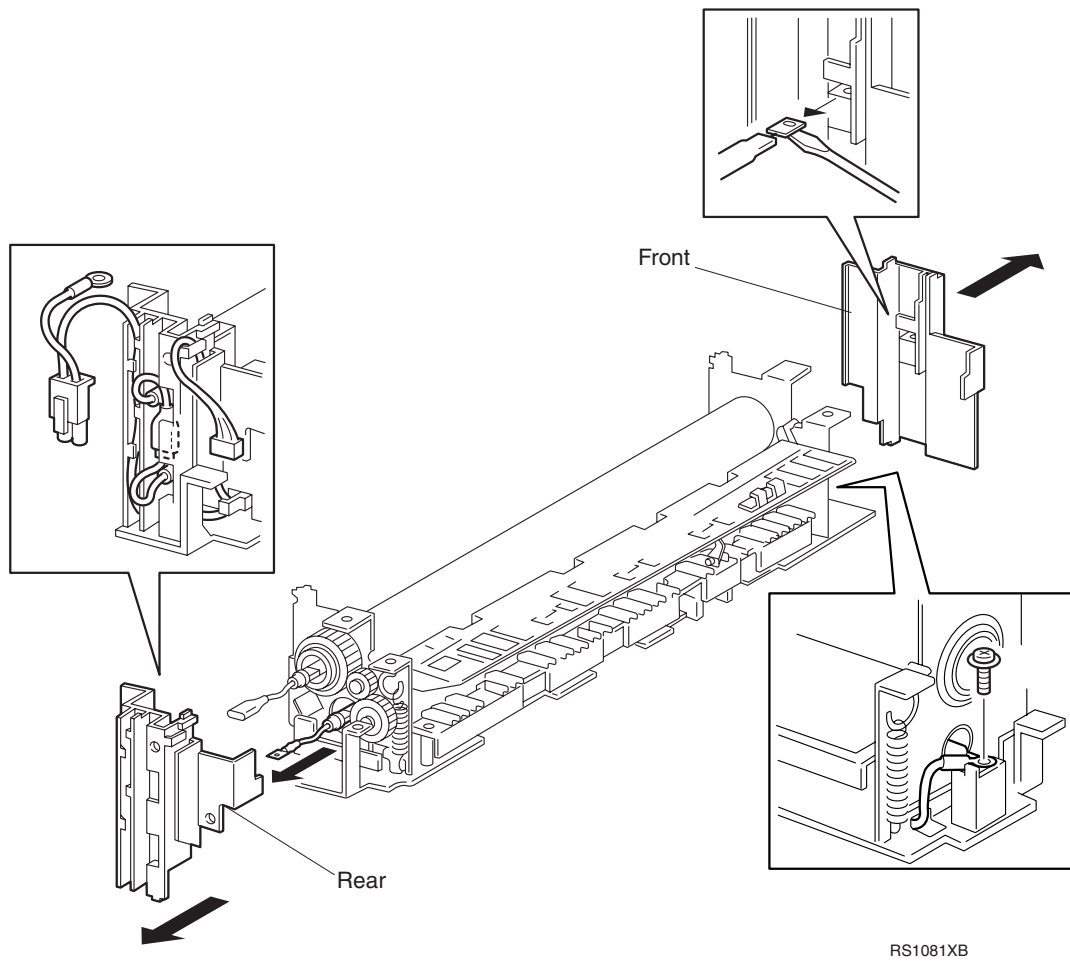

RS1081XB



## RRP 9.86 Heat Roll Heat Rod (PL9.2.20)

---

### Removal

1. Remove the Upper Fuser Assembly (RRP 9.87).
2. Remove the shrink tubing that is covering the connectors linking the Pressure Roll Heat Rod and the Heat Roll Heat Rod.
3. Push out on the connector latch and disconnect the two Rods from each other.
4. Remove the screw securing the front of the Heat Roll Heat Rod to the front of the Main Fuser Assembly.
5. Free the rear of Heat Roll Heat Rod from the Fuser Rear Cover.
6. Slide the Heat Roll Heat Rod out of the Heat Roll.

### Replacement



*Handle the Heat Rod by the ceramic end tips. If you accidentally touch the glass tube, wipe the it clean with a soft, dry cloth.*

1. Carefully insert the flat end of the Heat Rod into the rear of the Heat Roll and push the Rod until the flat end exits the front of the Heat Roll
2. Use one screw to connect the front of the Heat Roll Heat Rod to the front of the Main Fuser Assembly.
3. Insert the rear of the Heat Roll Heat Rod and the rear of the Pressure Roll Heat Rod through the cut-outs in the Rear Fuser Cover.
4. Reconnect the Heat Roll Heat Rod to the Pressure Roll Heat Rod.
5. Reinstall a new piece of shrink tubing over the connection.
6. Reinstall the Upper Fuser Assembly (RRP 9.87).

## RRP 9.87 Upper Fuser Assembly (PL9.2.23)

---

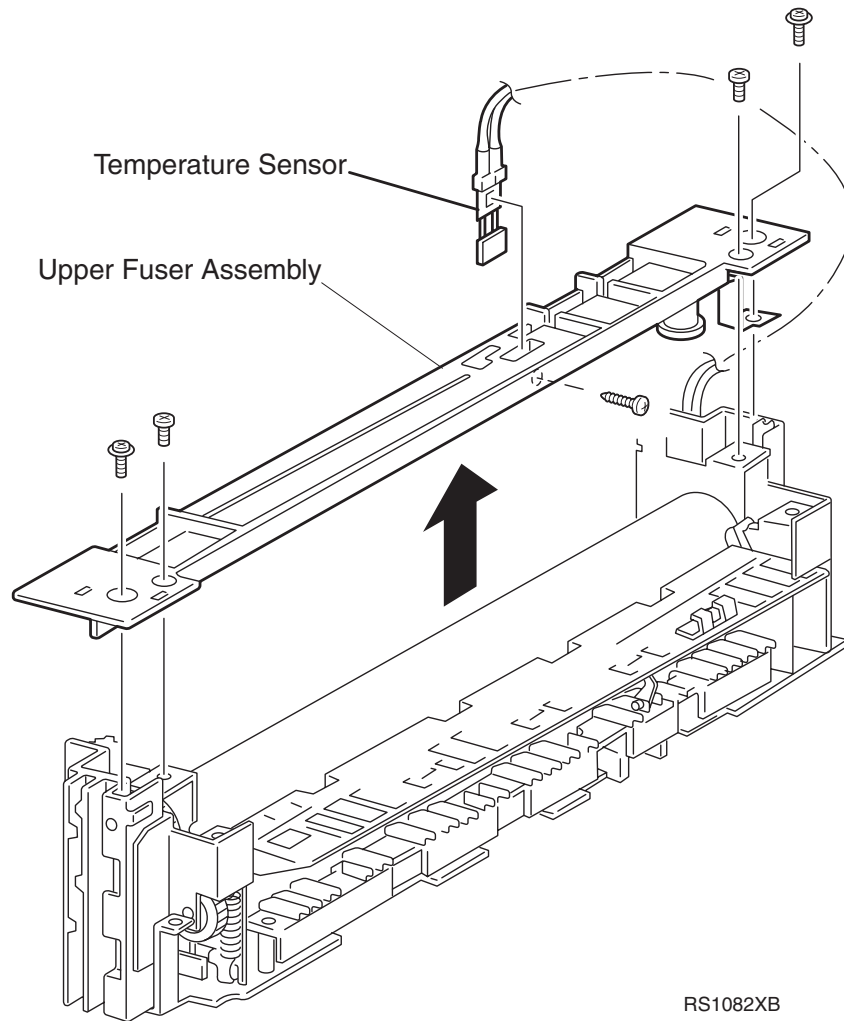

RS1082XB

## **RRP 9.87 Upper Fuser Assembly (PL9.2.23)**

---

### **Removal**

1. Remove the Main Fuser Assembly (RRP 9.81).
2. Remove the screw, located at the bottom of a long access hole at the front of the Upper Fuser Assembly, that secures the copper strap coming from the Upper Fuser Assembly to the Fuser Front Cover.
3. Remove the screw, located at the bottom of a long access hole at the rear of the Upper Fuser Assembly, that secures the copper strap coming from the Upper Fuser Assembly to the Fuser Rear Cover.
4. Remove the two screws securing the Upper Fuser Assembly to the Main Fuser Assembly and remove the Upper Fuser Assembly.
5. Remove the Fuser Temperature Sensor (RRP 9.88).

### **Replacement**

1. Reinstall the Fuser Temperature Sensor (RRP 9.88).
2. Make sure the Fuser Rear Cover is in place on the Main Fuser Assembly.
3. Make sure the Fuser Front Cover is in place on the Main Fuser Assembly and that the flat end of the Pressure Roll Heat Rod is resting on top of the metal screw hole inside the Fuser Front Cover.
4. Reinstall the Upper Fuser Assembly on top of the Main Fuser Assembly, making sure the tabs on the Main Fuser Assembly fit through the slots in the Upper Fuser Assembly.
5. Make sure the screw holes in the ends of the copper strap line up with the screw holes in the Fuser Rear and Fuser Front Covers.
6. Use two screws to secure the Upper Fuser Assembly to the Main Fuser Assembly.
7. Insert the heavy black wire into the slot in the Fuser Rear Cover so the black wire connector is over the copper strap.
8. Place one screw down the access hole at the rear of the Upper Fuser Assembly to secure the black wire connector and the copper strap to the Fuser Rear Cover.
9. Place one screw down the access hole at the front of the Upper Fuser Assembly to secure the copper strap to the Fuser Front Cover.
10. Reinstall the Main Fuser Assembly (RRP 9.81).

## RRP 9.88 Temperature Sensor Assembly (PL9.2.24)

---

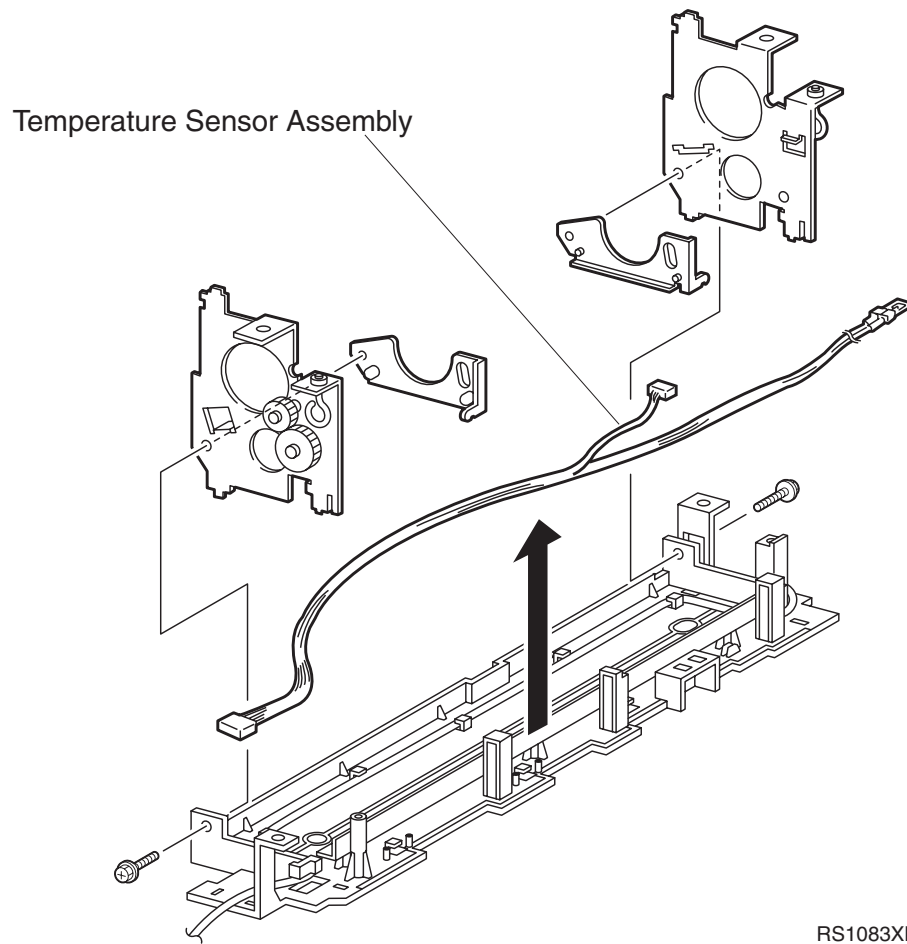

RS1083XB

## **RRP 9.88 Temperature Sensor Assembly (PL9.2.24)**

---

### **Removal**

1. Remove the Upper Fuser Assembly (RRP 9.87).
2. Remove the screw securing the Temperature Sensor to the Upper Fuser Assembly.
3. Disconnect P/J 75 from the Fuser Exit Sensor.
4. Remove the Temperature Sensor and the wire harness from the Upper Fuser Assembly.

### **Replacement**

1. Insert the Temperature Sensor through the opening in the top of the Upper Fuser Assembly.
2. Position the Sensor so the sensing head faces up.
3. Align the screw hole and positioning tab on the Sensor with the screw hole and positioning hole on the Upper Fuser Assembly.
4. Use one screw to secure the Temperature Sensor to the Upper Fuser Assembly.
5. Route the wire harness along the top of the Upper Fuser Assembly, down the side of the Front Fuser Cover, across the Fuser Bottom Plate, under the Rear Fuser Cover, and out the Rear of the Upper Fuser Assembly.
6. Reconnect P/J 75 to the Fuser Exit Sensor.
7. Secure the wire harness under all of the harness clips that are molded into the Upper Fuser Assembly.
8. Reinstall the Upper Fuser Assembly (RRP 9.87).

## RRP 9.89 Fuser Exit Sensor (PL9.2.25)

---

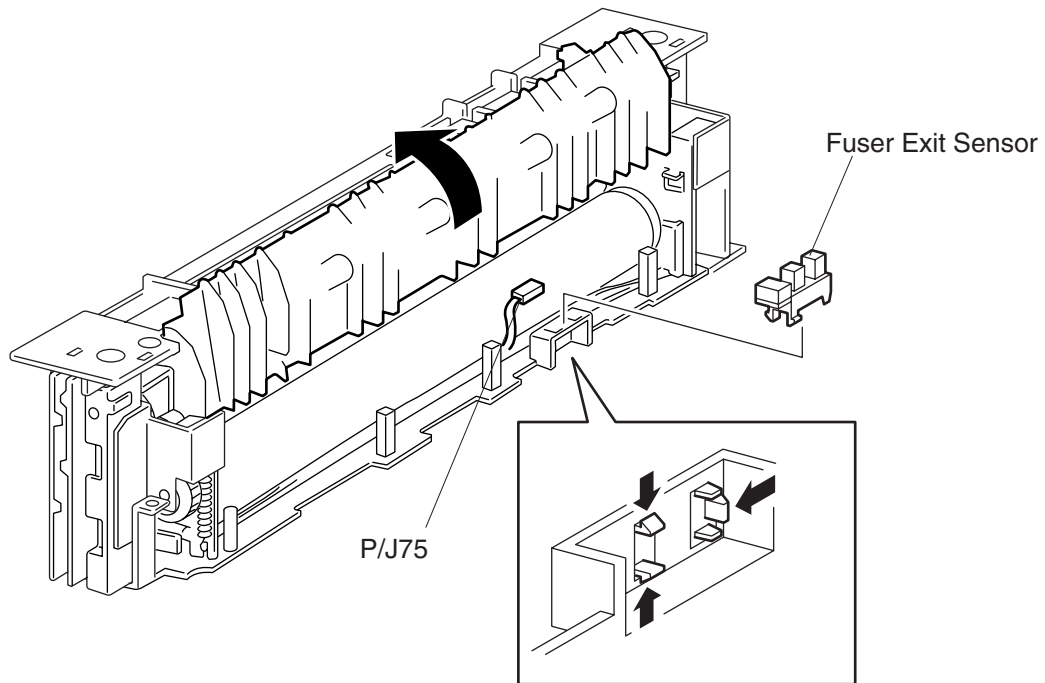

RS1084XB

RS1084XB

## **RRP 9.89 Fuser Exit Sensor (PL9.2.25)**

---

### **Removal**

1. Remove the Main Fuser Assembly (RRP 9.81).
2. Raise the Upper Guide Assembly so it is out of the way.
3. Remove the screw securing the Lower Exit Guide to the Main Fuser Assembly.
4. Slide the Lower Exit Guide to the to free the three latches that are located under the Guide and remove the Guide from the Main Fuser Assembly.
5. Disconnect P/J 75 from the Fuser Exit Sensor.
6. Squeeze the latches securing the Fuser Exit Sensor to the Main Fuser Assembly and remove the Sensor.

### **Replacement**

1. Position the Fuser Exit Sensor against the cutouts in the Main Fuser Assembly.
2. Press the Fuser Exit Sensor into the cutouts until the latches snap into place.
3. Reconnect P/J 75 to the Fuser Exit Sensor.
4. Use a lightly sticky tape back the four Pressure Roll Fingers that are attached to the Lower Exit Guide.
5. Make sure the Fuser Exit Sensor Actuator is still in place on the Lower Exit Guide.
6. Press and hold the Fuser Exit Sensor Actuator while you reinstall the Lower Exit Guide.
7. Reinstall the Lower Exit Guide onto the Main Fuser Assembly by first positioning the Guide slightly to the left of center, then sliding the Guide to the right so the three latches under the Guide engage the three slots in the Main Fuser Assembly.
8. Release the Fuser Exit Sensor Actuator and check the action to make sure it moves smoothly and is positioned between the arms of the Fuser Exit Sensor.
9. Remove the tape from the four Pressure Roll Fingers, make sure there is no tape residue left on the Fingers and make sure they all ride on the surface of the Press Roll.
10. Use one screw to secure the Lower Exit Guide to the Main Fuser Assembly.
11. Lower the Upper Guide Assembly.
12. Reinstall the Main Fuser Assembly (RRP 9.81).

## RRP 9.90 Exit-1 Roll Assembly (PL9.3.7)

---

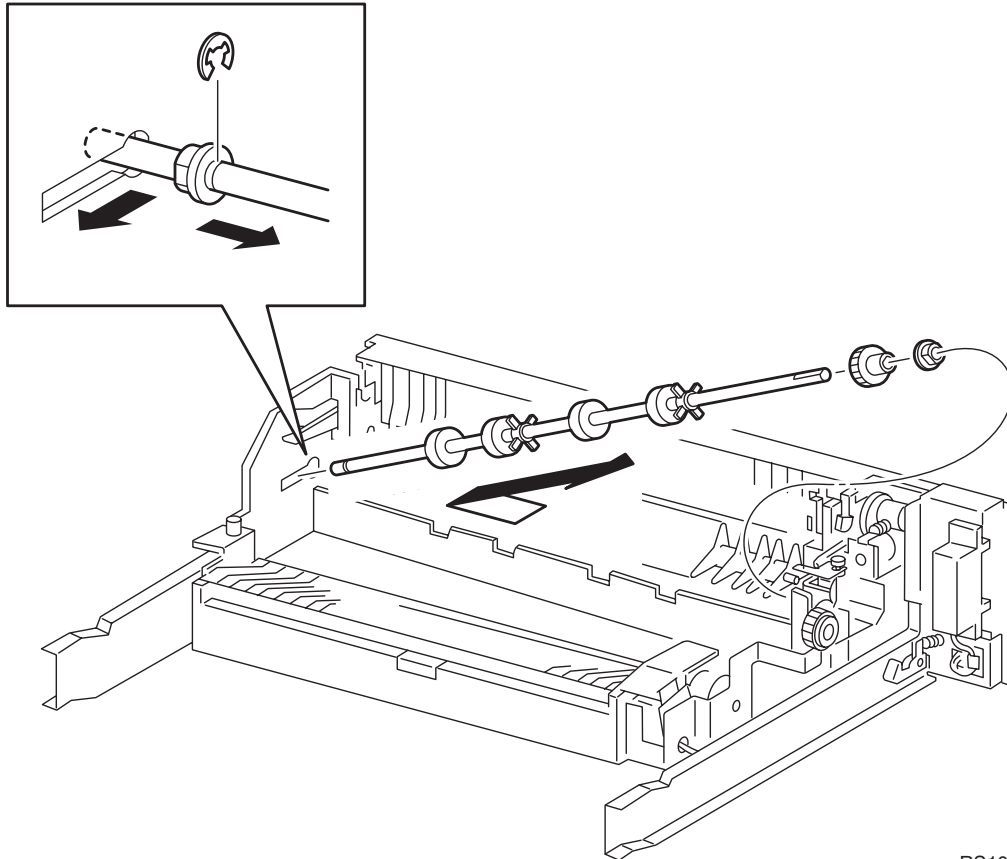

RS1085XB

RS1085XB



## **RRP 9.90 Exit-1 Roll Assembly (PL9.3.7)**

---

### **Removal**

1. Remove the Main Fuser Assembly (RRP 9.81).
2. Place the Fuser Tray Assembly on a flat and stable work surface.
3. Remove the E ring securing the front of the Exit-1 Roll Shaft to the front bearing and slide the bearing back along the Shaft.
4. Slide the front of the Shaft along the slot in the front of the Fuser Tray Assembly so you can free the rear of the Shaft from the rear bearing.
5. Remove the Shaft, along with the Exit-1 Gear, from the Fuser Tray Assembly.

### **Replacement**

1. Make sure the rear bearing is still in place in the cutout at the rear of the Fuser Tray Assembly.
2. Slide the front bearing, with the collar facing the rubber rollers, over the front of the Exit-1 Roll Assembly Shaft.
3. Slide the Exit-1 Gear, with the large side facing the rubber rollers, over the rear of the Exit-1 Roll Assembly.
4. Position the Shaft so the rubber rollers line up with the cutouts in the Fuser Tray Assembly.
5. Insert the front of the Shaft into the slot in the front of the Fuser Tray Assembly.
6. Insert the rear of the Shaft into the rear bearing.
7. Slide the front of the Shaft toward the front bearing cutout in the Fuser Tray Assembly.
8. Slide the front bearing into place in the cutout and use an E ring to secure the Exit-1 Roll Shaft to the front bearing.
9. Reinstall the Main Fuser Assembly (RRP 9.81).

## RRP 9.91 Exchange Chute (PL9.3.10)

---

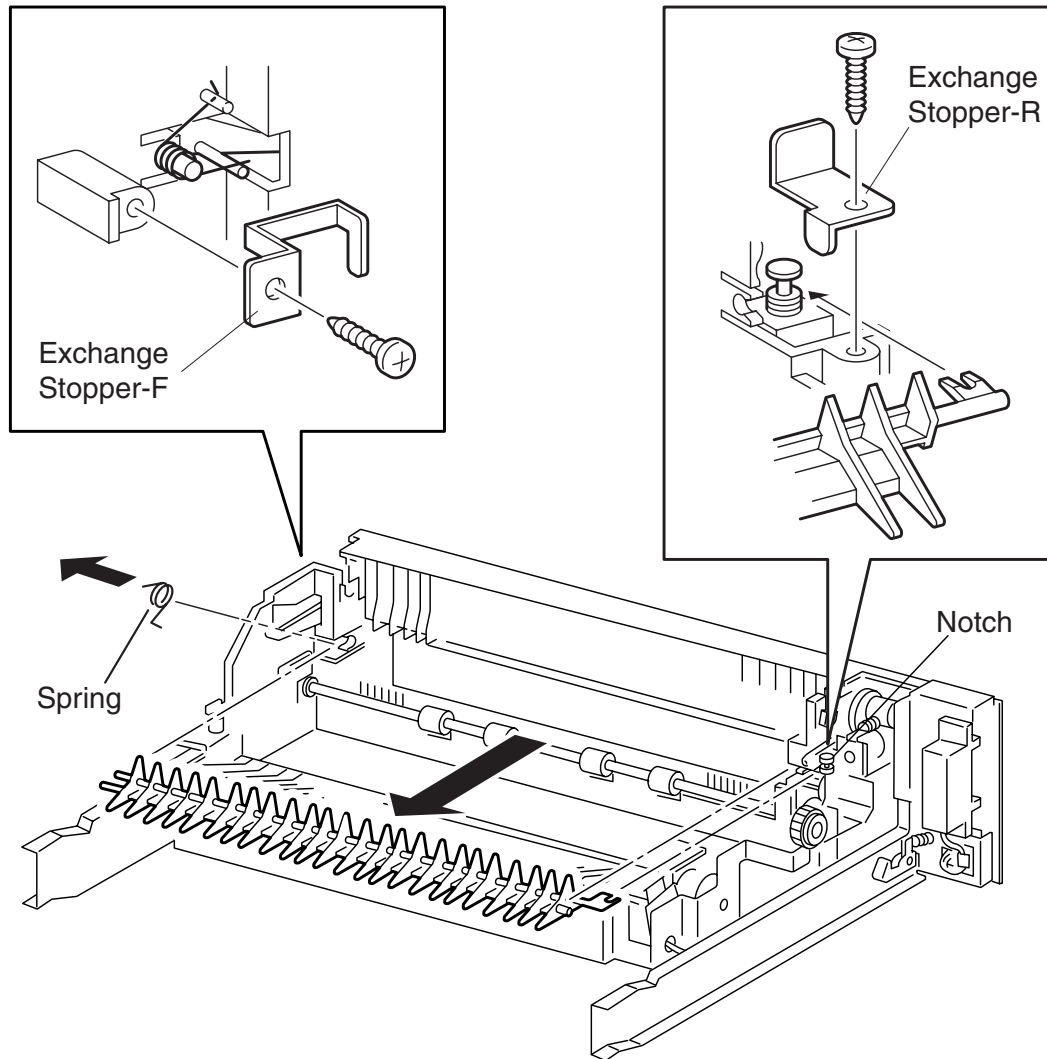

RS1086XC

RS1086XC

## **RRP 9.91 Exchange Chute (PL9.3.10)**

---

### **Removal**

1. Remove the Main Fuser Assembly (RRP 9.81).
2. Place the Fuser Tray on a flat and stable work surface.
3. Remove the screw securing the Exchange Stopper-R to the Tray and remove the Stopper.
4. Pull the rear of the Exchange Chute free from the Exchange Solenoid.
5. Remove the screw securing the Exchange Stopper-F to the Tray and remove the Stopper.
6. Pull the front of the Exchange Chute, along with the Exchange Spring, free from the notch in the front of the Fuser Tray and remove the Exchange Chute.

### **Replacement**

1. Insert the front of the Exchange Chute, the straight end, into the notch in the front of the Fuser Tray.
2. Insert the rear of the Exchange Chute, the forked end, into the notch in the rear of the Fuser Tray, making sure the fork engages the Exchange Solenoid plunger.
3. Reinstall the Exchange Spring onto the front end of the Exchange Chute, making sure the straight end of the Spring rests on top of the Chute arm and the hooked end of the Spring is captured by the tab extending from the Fuser Tray.
4. Reinstall the Exchange Stopper-F to the Tray and use one screw to secure the Stopper.
5. Reinstall the Exchange Stopper-R to the Tray and use one screw to secure the Stopper.
6. Reinstall the Main Fuser Assembly (RRP 9.81).

## RRP 9.92 Exchange Solenoid (PL9.3.16)

---

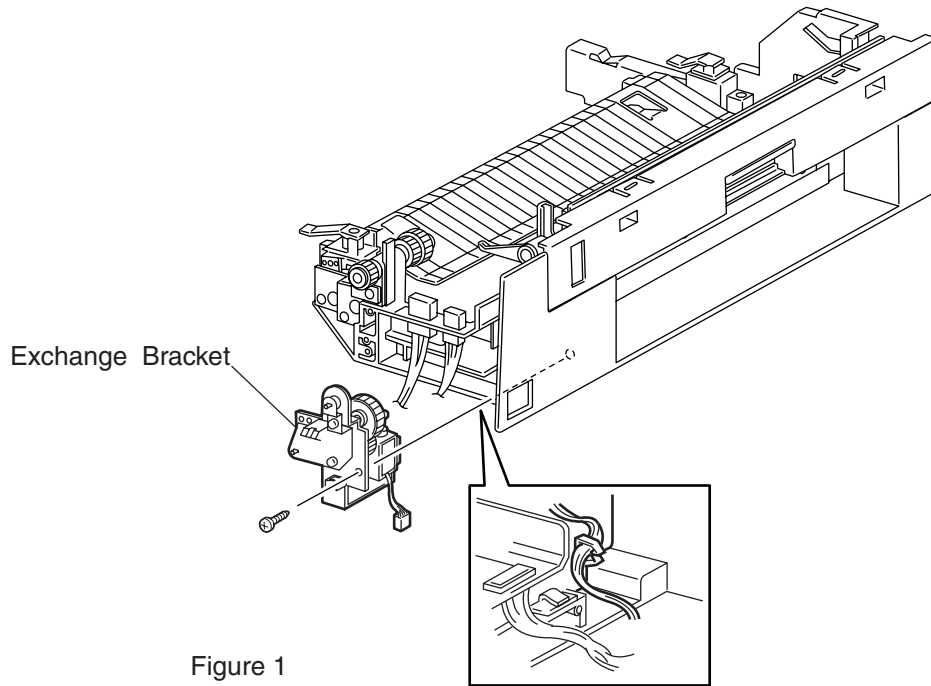

Figure 1

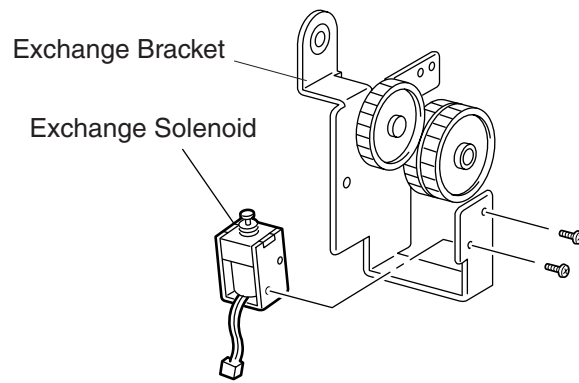

Figure 2

RS1087XB

RS1087XB

## **RRP 9.92 Exchange Solenoid (PL9.3.16)**

---

### **Removal**

1. Remove the Oil Cam Solenoid (RRP 9.93).
2. Remove the Exchange Chute (RRP 9.91).
3. Remove the screw securing the Exchange Bracket to the Fuser Tray and slide the Exchange Bracket out of the Tray (Figure 1).
4. Remove the two screws securing the Exchange Solenoid to the Exchange Bracket and remove the Solenoid (Figure 2).

### **Replacement**

1. Reinstall the Exchange Solenoid onto the Exchange Bracket.
2. Line up the two screw holes in the Solenoid with the two screw holes in the Bracket.
3. Use two screws to secure the Solenoid to the Bracket.
4. Line up the positioning tab on the Fuser Tray with the positioning hole in the Exchange Bracket and reinstall the Bracket the Tray.
5. Reposition the Bracket as necessary to make sure the Oil Cam Assembly shaft fits through the hole in the Bracket and the Idler Gear shaft fits into the hole in the Fuser Tray.
6. Use two screws to secure the Exchange Bracket to the Fuser Tray.
7. Reinstall the Exchange Chute (RRP 9.91).
8. Reinstall the Oil Cam Solenoid (RRP 9.93).

## RRP 9.93 Oil Cam Solenoid (PL9.3.21)

---

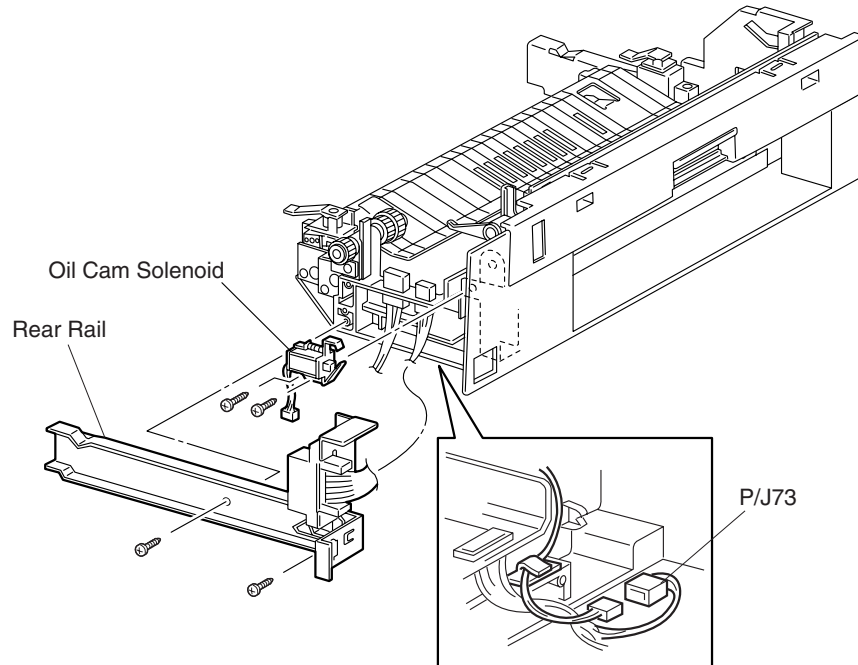

Figure 1

Position of Solenoid arms against Cam

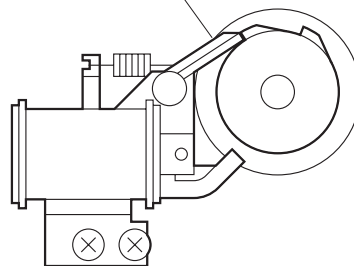

Figure 2

RS1088XB

RS1088XB

## **RRP 9.93 Oil Cam Solenoid (PL9.3.21)**

---

### **Removal**

1. Remove the Main Fuser Assembly (RRP 9.81).
2. Place the Fuser Tray on a flat and stable work surface.
3. Remove the two screws securing the Fuser Rear Rail to the Fuser Tray and pull the Rail away from Tray (Figure 1).
4. Disconnect P/J 73 from the Oil Cam Solenoid.
5. Remove the two screws securing the Oil Cam Solenoid to the Fuser Tray and remove the Solenoid.

### **Replacement**

1. Line up the screw holes in the Oil Cam Solenoid with the screw holes in the Fuser Tray.
2. Reinstall the Oil Cam Solenoid onto the Fuser Tray and use two screws to secure the Solenoid to the Tray.  
Make sure the Solenoid arms rest on the Cam as shown in Figure 2.
3. Reconnect P/J 73 to the Oil Cam Solenoid.
4. Line up the positioning hole and screw holes in the Fuser Rear Rail with the positioning tab and screw holes in the Fuser Tray.
5. Reinstall the Fuser Rear Rail onto the Fuser Tray and use two screws to secure the Rail to the Tray.
6. Reinstall the Main Fuser Assembly (RRP 9.81).

## RRP 9.94 Oil Cam Assembly (PL9.3.22)

---

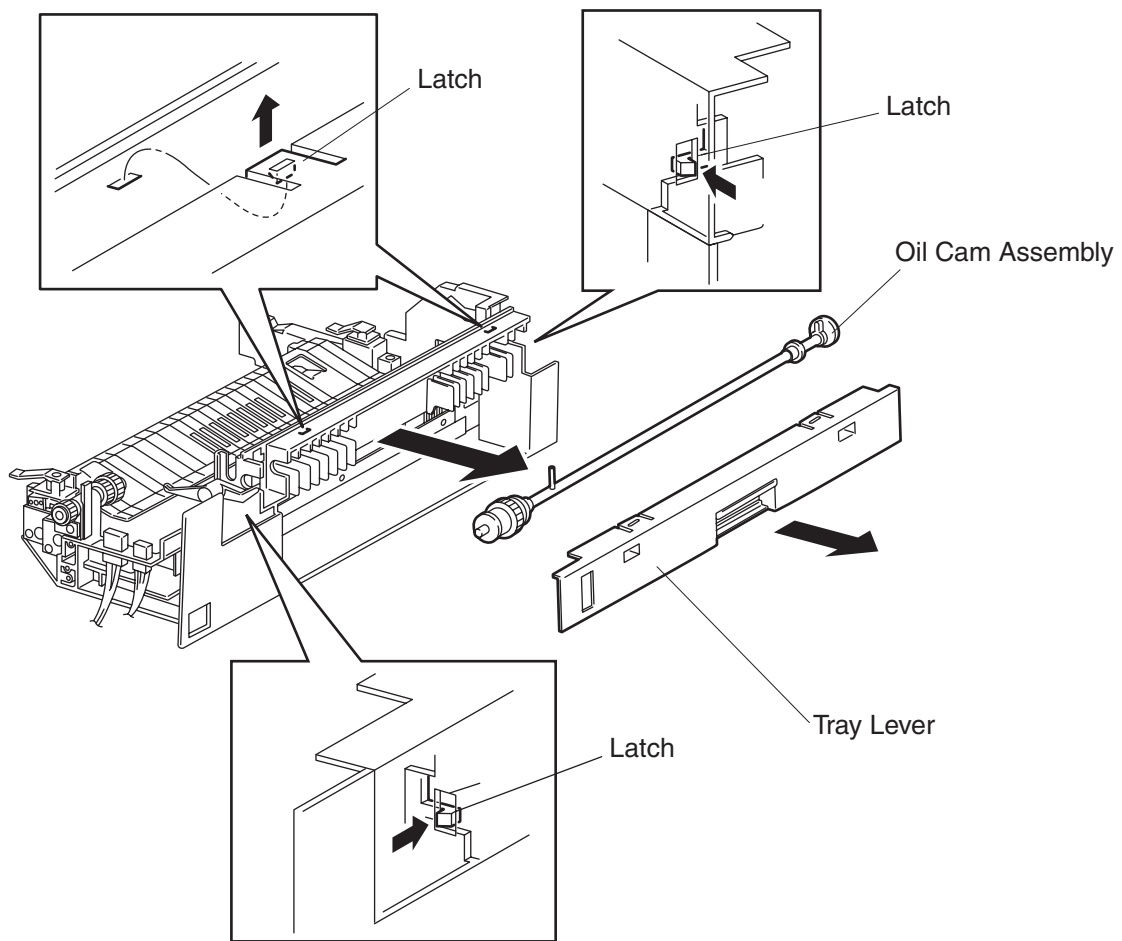

RS1089XB

RS1089XB



## **RRP 9.94 Oil Cam Assembly (PL9.3.22)**

---

### **Removal**

1. Remove the Oil Cam Solenoid (RRP 9.93).
2. Gently pry up and release the two latches on the top of the Fuser Tray Lever, and also release the two latches, one on either end of the Tray Lever, and remove the Lever.
3. Remove the E ring securing the front of the Oil Cam Assembly to the Fuser Tray.
4. Slide the front bear forward and swing the front of the Oil Cam Assembly out of the channel in the Fuser Tray.
5. Push the Exchange Bracket away from the rear of the Oil Cam Assembly as you continue pulling the front of the Oil Cam Assembly away from the Tray.  
The rear of the Assembly pops out of the Bracket.
6. Remove the Oil Cam Assembly.

### **Replacement**

1. Insert the rear of the Oil Cam Assembly into the hole in the Exchange Bracket.
2. Push down on the Oil Link to move it out of the way as you swing the front end of the Oil Cam Assembly into the channel in the Fuser Tray.
3. When the Oil Cam Solenoid is in place in the channel slide the front and rear bearings into the front and rear bearing notches.
4. Use an E ring to secure the front of the Oil Cam Assembly to the Fuser Tray.
5. Position the Fuser Tray lever so the two latches on the Top of the Lever line up with the two catches on the top of the Fuser Tray.
6. Push the Fuser Lever onto the Fuser Tray.  
The four latches snap into place.
7. Reinstall the Oil Cam Solenoid (RRP 9.93).

## RRP 9.95 CRU Switch Assembly (PL9.3.25)

---

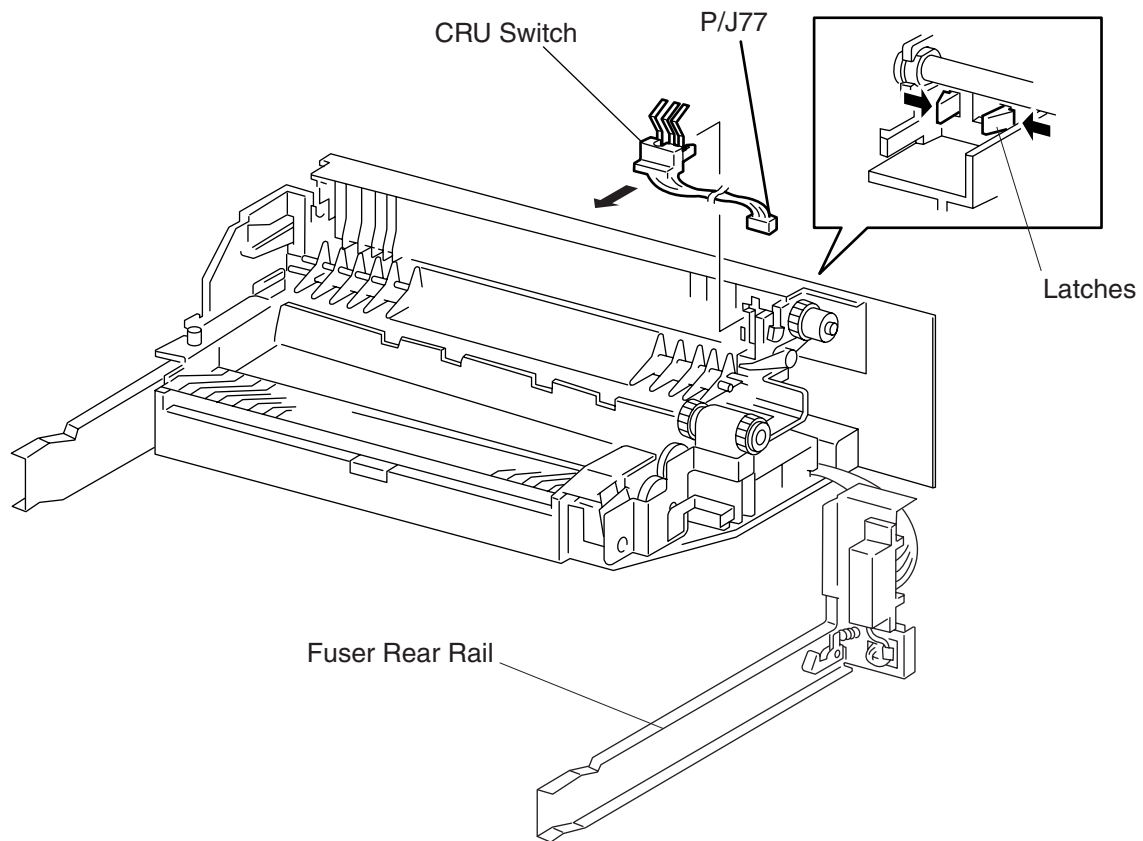

RS1090XB

RS1090XB

## **RRP 9.95 CRU Switch Assembly (PL9.3.25)**

---

### **Removal**

1. Remove the Fuser Assembly (RRP 9.80).
2. Remove the Oil Roll Assembly (RRP 9.82).
3. Remove the two screws securing the Fuser Rear Rail and remove the Rail.
4. Gently pry up the two latches on the top of the Fuser Tray Lever and release the two side latches, one on either end of the Tray Lever, and remove the Lever.
5. Disconnect P/J77 from the CRU Switch.
6. Squeeze the latches securing the CRU Switch to the Fuser frame and remove the Switch.

### **Replacement**

1. Reinstall the CRU Switch Assembly by first threading the wire harness down the hole in the Fuser frame and out through the rear of the frame.
2. Push the CRU Switch against the Fuser frame until the latches lock the Switch into place.
3. Reconnect P/J77 to the CRU Switch.
4. Reinstall the Fuser Tray Lever.
5. Reinstall the Fuser Rear Rail and use two screws to secure the Rail to the Fuser frame.
6. Position the Fuser Tray lever so the two latches on the Top of the Lever line up with the two catches on the top of the Fuser Tray.
7. Push the Fuser Lever onto the Fuser Tray.
8. The four latches snap into place.
9. Reinstall the Oil Roll Assembly (RRP 9.82).
10. Reinstall the Fuser Assembly (RRP 9.80).

## RRP 9.96 Cleaner Cam Solenoid (PL9.4.23)

---

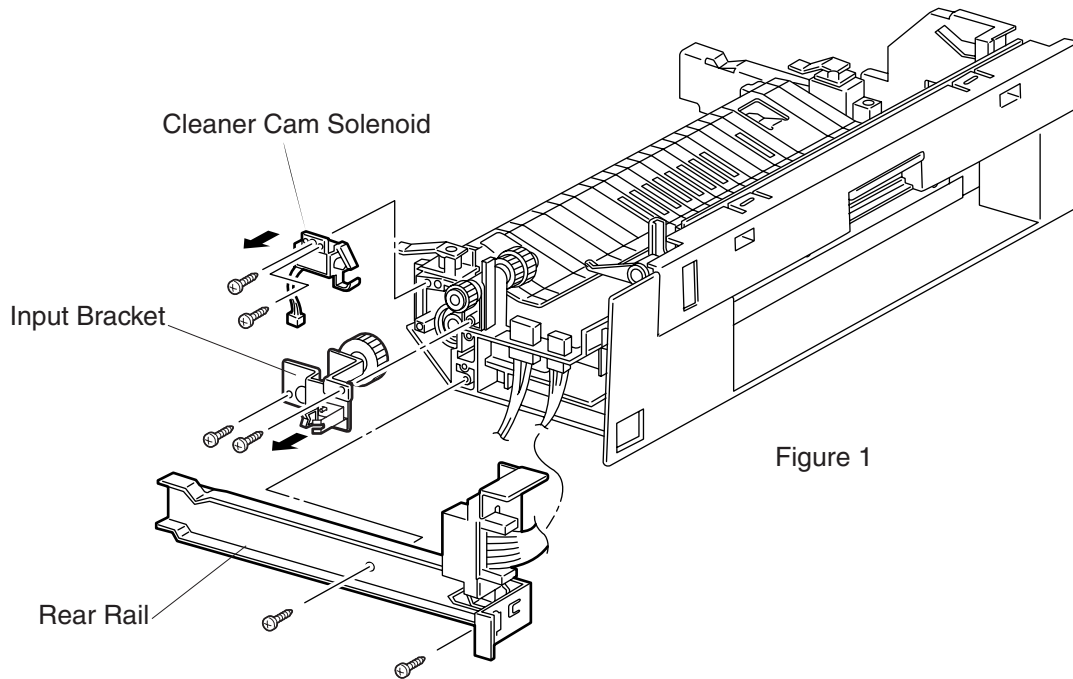

Figure 1

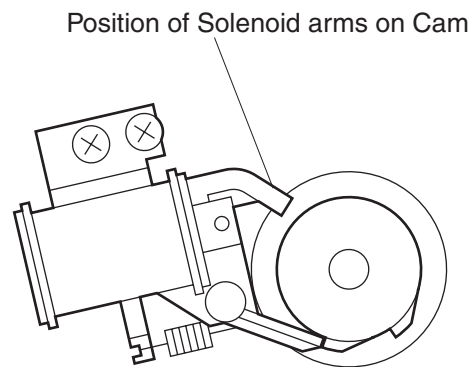

Figure 2

RS1091XB

RS1091XB

## **RRP 9.96 Cleaner Cam Solenoid (PL9.4.23)**

---

### **Removal**

1. Remove the Main Fuser Assembly (RRP 9.81).
2. Place the Fuser Tray on a flat and stable work surface.
3. Remove the two screws securing the Fuser Rear Rail to the Fuser Tray and pull the Rail away from Tray (Figure 1).
4. Disconnect P/J 62 from the Cleaner Cam Solenoid and free the wire from the wire clip that is attached to the Input Bracket.
5. Remove the two screws securing the Input Bracket to the Fuser Tray and pull the Bracket away from the Tray.
6. Remove the screw securing the Cleaner Cam Solenoid to the Fuser Tray and remove the Solenoid.

### **Replacement**

1. Line up the positioning hole and screw hole in the Cleaner Cam Solenoid with the positioning tab and screw hole in the Fuser Tray.
2. Reinstall the Cleaner Cam Solenoid onto the Fuser Tray and use one screw to secure the Solenoid to the Tray.  
Make sure the Solenoid arms rest on the Cam as shown in Figure 2.
3. Route the Solenoid wire harness through the hole in the Input Bracket.
4. Line up the end of the Cleaner Cam Assembly shaft with the hole in the Input Bracket and reinstall the Bracket onto the Fuser Tray.
5. Use two screw to secure the Input Bracket to the Fuser Tray.
6. Reconnect P/J 62 to the Cleaner Cam Solenoid and secure the wire under the wire clip that is attached to the Input Bracket.
7. Line up the positioning hole and screw holes in the Fuser Rear Rail with the positioning tab and screw holes in the Fuser Tray.
8. Reinstall the Fuser Rear Rail onto the Fuser Tray and use two screws to secure the Rail to the Tray.
9. Reinstall the Main Fuser Assembly (RRP 9.81).

## RRP 9.97 Cleaner Cam Assembly (PL9.4.26)

---

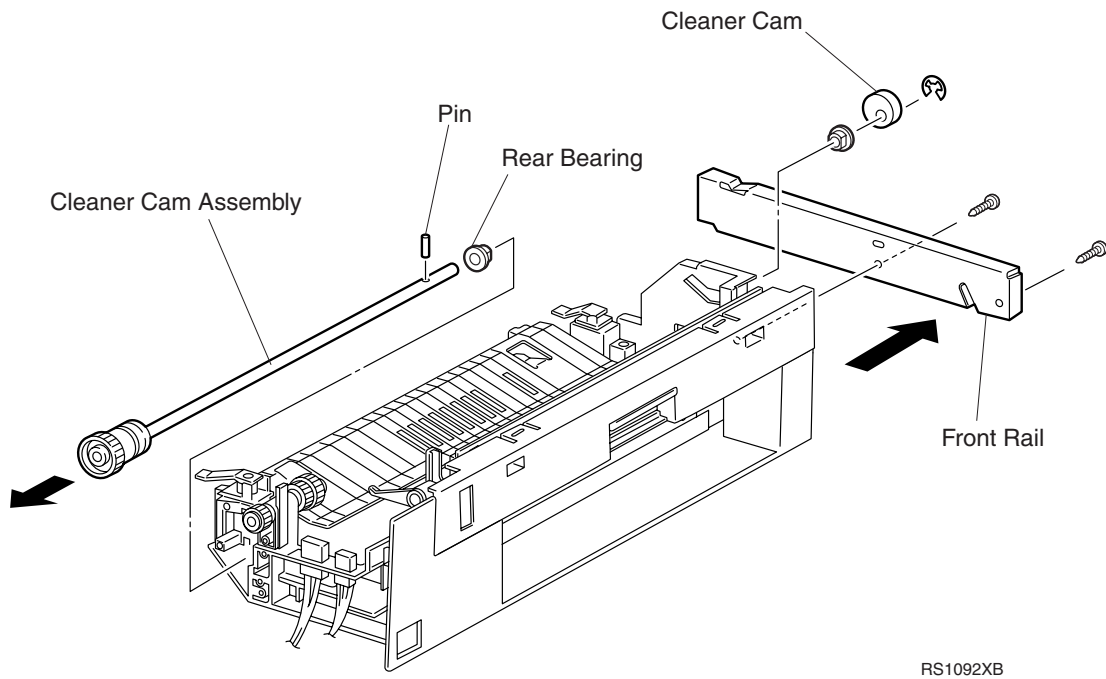

RS1092XB

## **RRP 9.97 Cleaner Cam Assembly (PL9.4.26)**

---

### **Removal**

1. Remove the Cleaner Cam Solenoid (RRP 9.96).
2. Remove the two screws securing the Fuser Front Rail to the Fuser Tray and remove the Rail.
3. Remove E ring securing Cleaner Cam to the Cleaner Cam Assembly shaft and remove the Cam.
4. Remove the pin from the front end of the Cleaner Cam Assembly shaft.
5. Slide the Cleaner Cam Assembly out of the Fuser Tray.

### **Replacement**

1. Slide the rear bearing, collar facing the rear of the shaft, onto the Cleaner Cam Assembly shaft.
2. Slide the Cleaner Cam Assembly into the hole in the rear of the Fuser Tray.
3. Slide the Cleaner Cam Assembly through the Fuser Tray so the front of the Cleaner Cam Assembly shaft exits through the front hole in the Fuser Tray.
4. Reposition the rear bearing so it fits into the bearing hole at the rear of the Fuser Tray.
5. Slide the front bearing, collar facing the front of the shaft, onto the Cleaner Cam Assembly shaft.
6. Reposition the front bearing so it fits into the bearing hole at the front of the Fuser Tray.
7. Insert the pin into the hole at the front end of the Cleaner Cam Assembly shaft.
8. Line up the slot in the rear of the Cleaner Cam with the pin at the front of the Cleaner Cam Assembly shaft.
9. Lift the Clean Cam Guide and slide the Cleaner Cam onto the shaft, making sure the pin fits into the slot in the rear of the Cleaner Cam.
10. Use an E ring to secure the Cam to the Cam Assembly shaft.
11. Reinstall the Fuser Front Rail and use two screws to secure the Rail to the Fuser Tray.
12. Reinstall the Cleaner Cam Solenoid (RRP 9.96).

## RRP 9.98 Upper Guide Assembly (PL9.2.32)

---

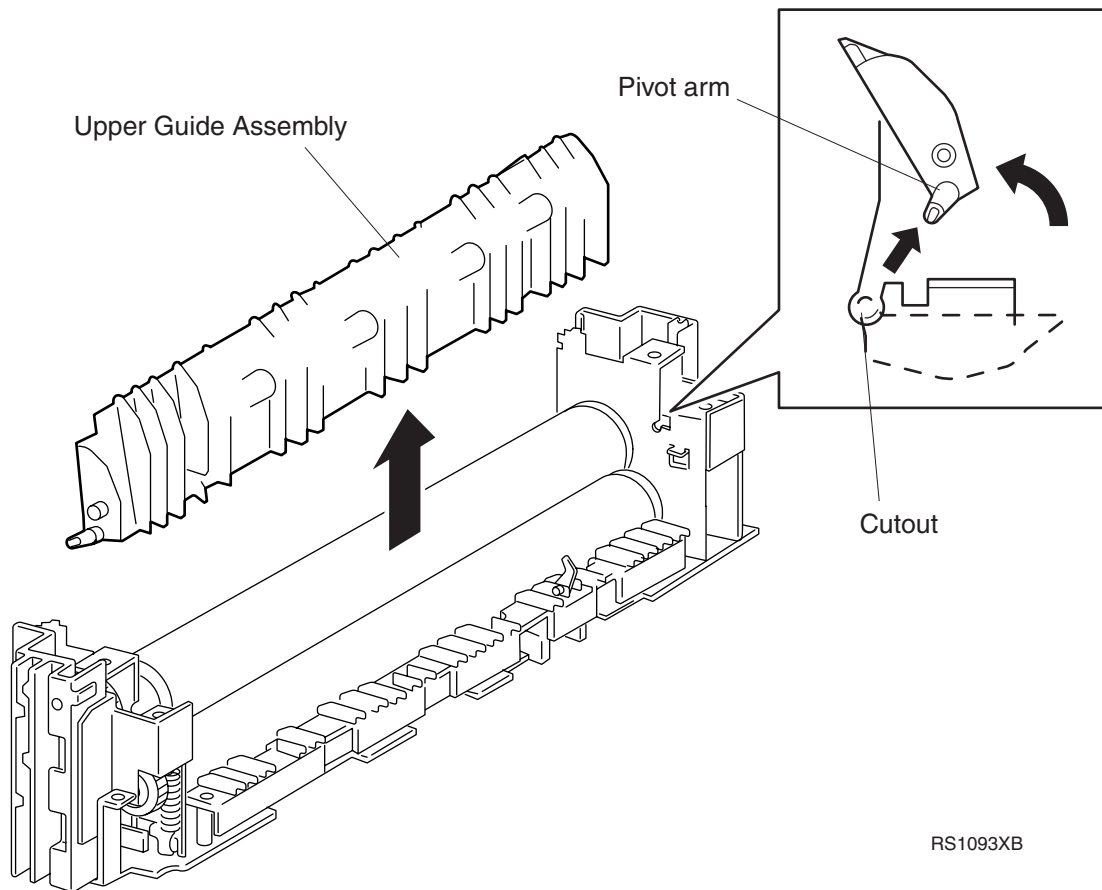

RS1093XB



## **RRP 9.98 Upper Guide Assembly (PL9.2.32)**

---

### **Removal**

1. Remove the Oil Roll Assembly (RRP 9.82).
2. Raise the Upper Guide Assembly and remove the pivot arms in the Assembly from the cutouts in the Fuser frame.

### **Replacement**

1. Position the Upper Guide Assembly as shown in the figure and insert the front and rear pivot arms into the cutouts in the Fuser frame.
2. Close the Upper Guide Assembly.
3. Reinstall the Oil Roll Assembly (RRP 9.82).

## RRP 9.99 Lower Guide Assembly (PL9.2.26)

---

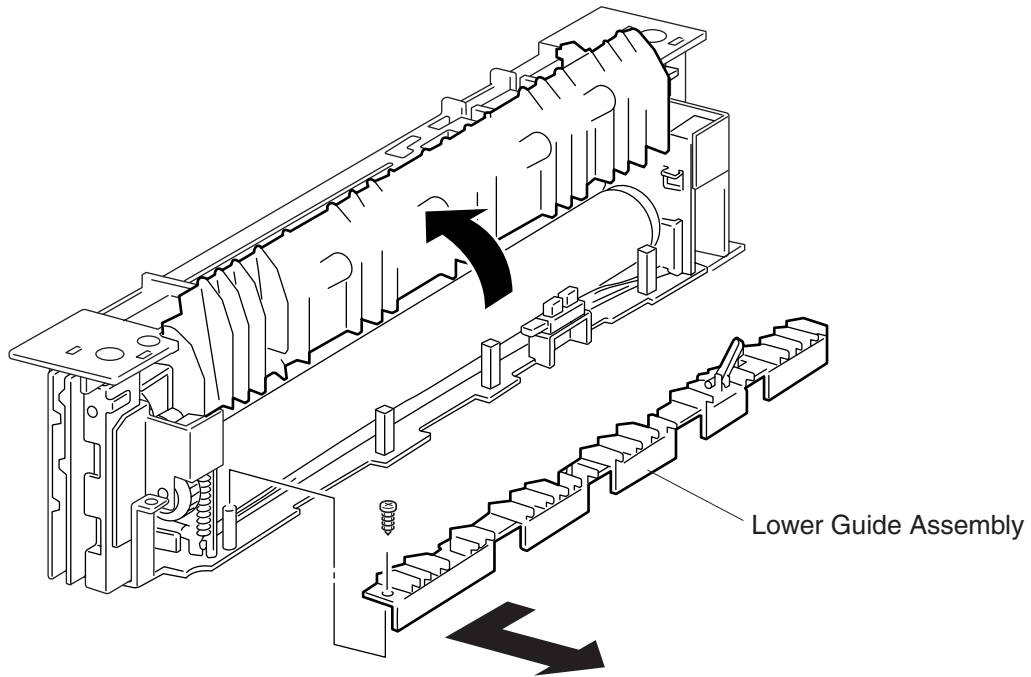

RS1094XB

RS1094XB

## **RRP 9.99 Lower Guide Assembly (PL9.2.26)**

---

### **Removal**

1. Remove the Upper Guide Assembly (RRP 9.98).
2. Remove the screw securing the Lower Guide Assembly to the frame.
3. Slide the Guide to the rear of the Fuser to unhook the latches, and remove the Guide.

### **Replacement**

1. Reinstall the Lower Exit Guide by positioning the Guide slightly to the rear of the installed position and with the Heat Roll Fingers resting on the Heat Roll.
2. Slide the Guide to the front of the Fuser, making sure you hook the three latches that are under the Guide.
3. Line up the screw hole in the Guide with the screw hole in the Fuser frame and use one screw to secure the Guide to the Fuser.
4. Reinstall the Upper Guide Assembly (RRP 9.98).

## RRP 9.100 Exit Tray (PL10.1.10)

---

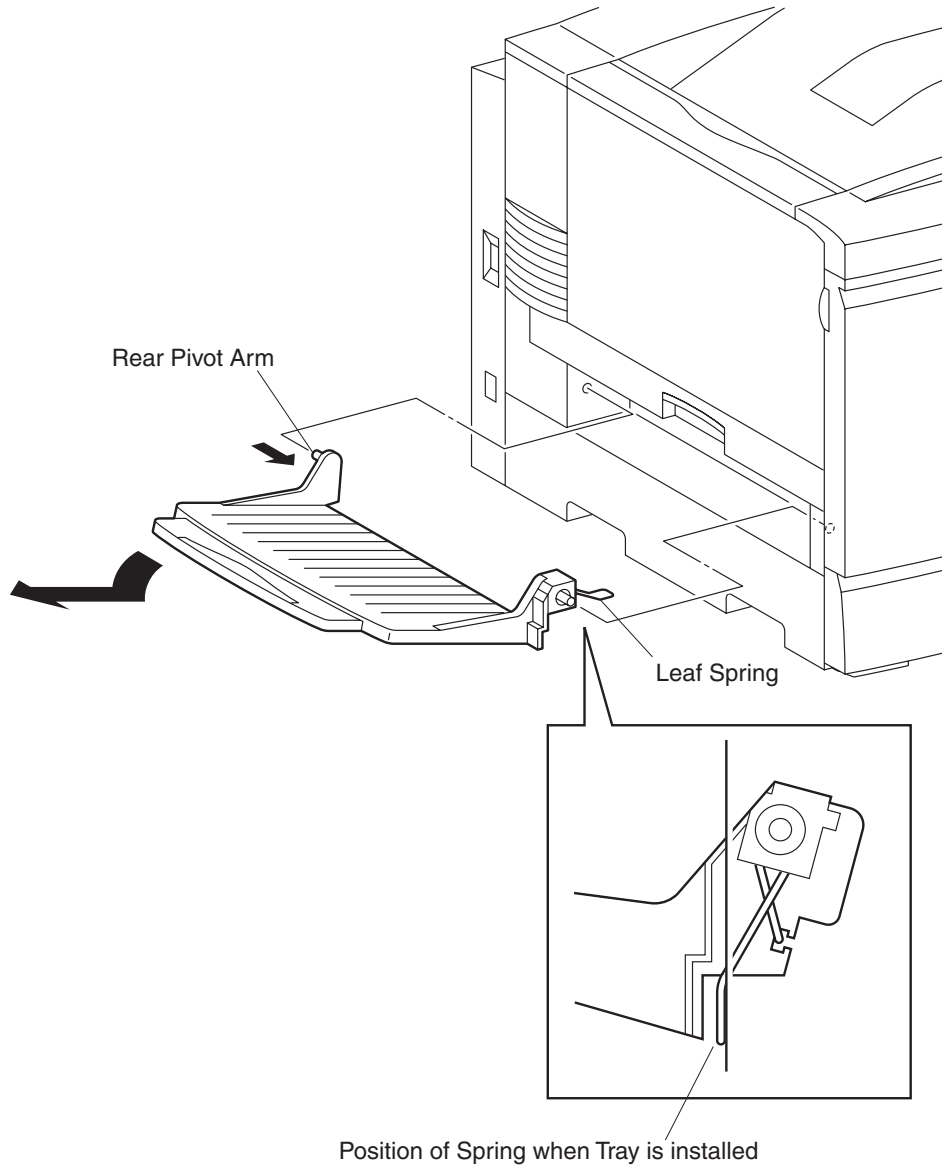

RS1095XB

RS1095XB

## **RRP 9.100 Exit Tray (PL10.1.10)**

---

### **Removal**

1. Collapse the Exit Tray extensions.
2. Close the Exit Tray.
3. Remove the front pivot arm of the Tray from the front pivot hole in the printer frame.
4. Remove the rear pivot arm of the Tray from the rear pivot hole in the printer frame and remove the Exit Tray.

### **Replacement**

1. Insert the rear pivot arm of the Tray into the rear pivot hole in the printer frame.
2. Pull down on the leaf spring that is located on the front pivot arm and insert the front arm into the front pivot hole, making sure the spring rests against the printer frame and is not inside the pivot hole.
3. Open and close the Exit Tray to make sure it moves smoothly.

## RRP 9.101 Lower Exit Assembly (PL10.1.1)

---

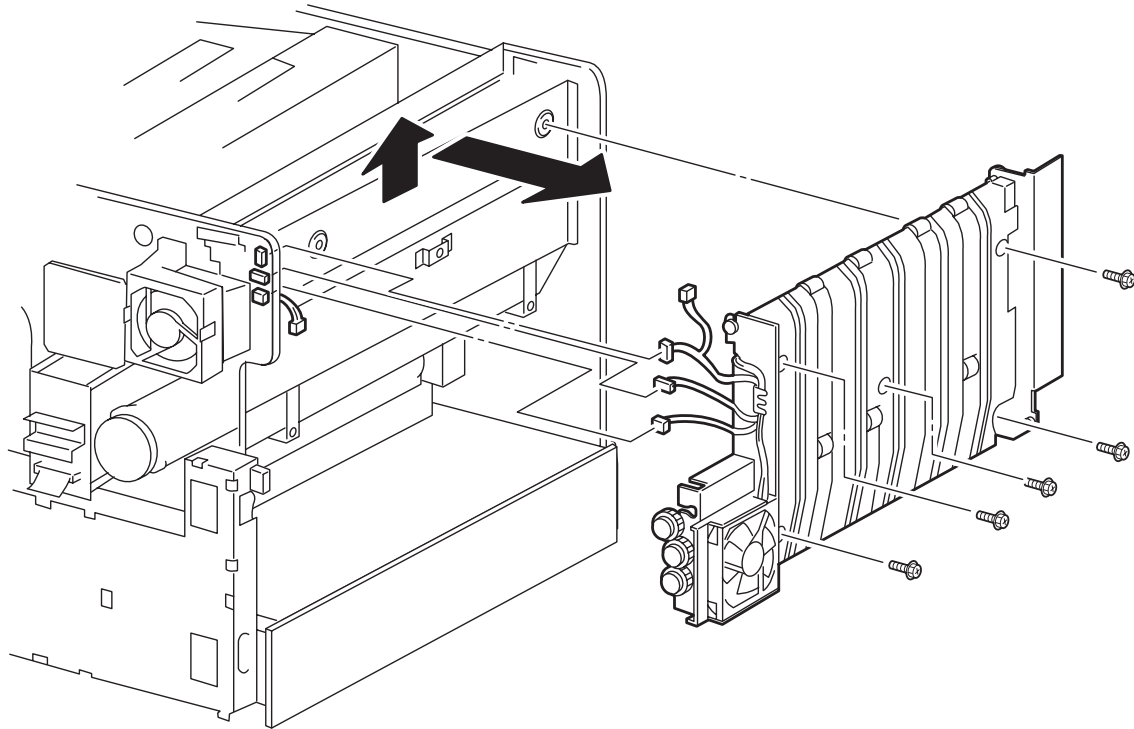

RS1096XB

RS1096XB

## **RRP 9.101 Lower Exit Assembly (PL10.1.1)**

---

### **Removal**

1. Remove the Upper Exit Assembly (RRP 9.102).
2. Disconnect P/J 161 from the P/J the near the top rear of the Lower Exit Assembly.
3. Disconnect P/J 111 from the P/J near the top rear of the Lower Exit Assembly.
4. Remove the five screws securing the Lower Exit Assembly to the printer frame.
5. Lift the Lower Exit Assembly to unhook the top of the Assembly from the printer frame and remove the Assembly.
6. Disconnect P/J 165 from the Top Exit Sensor and P/J 166 from the Exit Chute Switch, both located on the back of the Lower Exit Assembly.
7. Remove the wires from the wire clips that are molded into the side of the Lower Exit Assembly.

### **Replacement**

1. Reconnect P/J 165 to the Top Exit Sensor and P/J 166 to the Exit Chute Switch.
2. Route the wire harnesses through the groove in the top rear of the Lower Exit Assembly.
3. Hook the top of the Lower Exit Assembly onto the top of the printer frame and position the Assembly so the five screw holes in the Assembly line up with the five screw holes in the printer frame.
4. Use five screws to secure the Lower Exit Assembly to the printer frame.
5. Reconnect P/J 111 to the P/J near the top rear of the Lower Exit Assembly.
6. Reconnect P/J 161 to the P/J near the top rear of the Lower Exit Assembly.
7. Reinstall the wires under the wire clips that are molded into the side of the Lower Exit Assembly.
8. Reinstall the Upper Exit Assembly (RRP 9.102).

## RRP 9.102 Upper Exit Assembly (PL10.1.2)

---

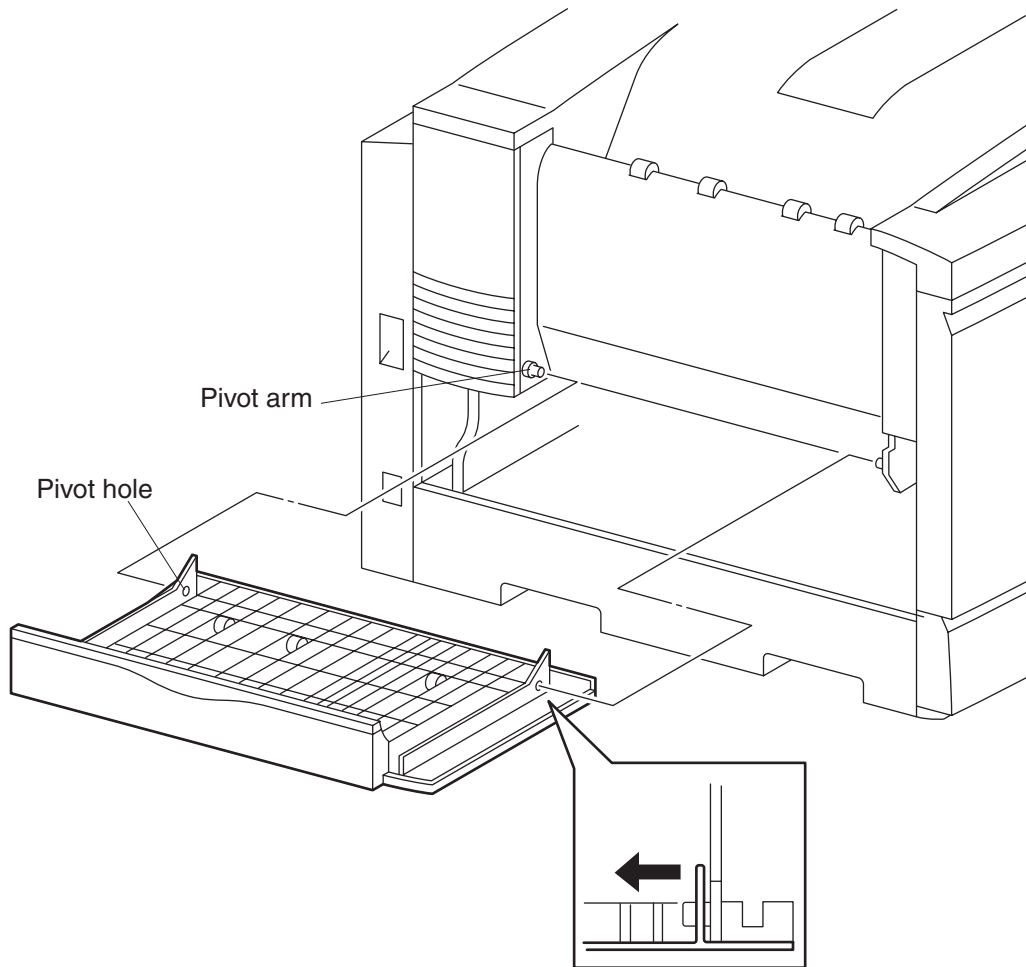

RS1097XB

RS1097XB



## **RRP 9.102 Upper Exit Assembly (PL10.1.2)**

---

### **Removal**

1. Open the Upper Exit Assembly.
2. Gently pry the Lower Exit Assembly rear pivot arm out of the pivot hole in the rear of the Upper Exit Assembly and remove the Upper Exit Assembly.

### **Replacement**

1. Position the Upper Exit Assembly at about a 45° angle to the printer frame.
2. Insert the front pivot hole of the Upper Exit Assembly into the front pivot arm of the Lower Exit Assembly.
3. Push in the on the rear of the Upper Exit Assembly enough so the rear pivot arm of the Lower Exit Assembly fits into the rear pivot hole of the Upper Exit Assembly.
4. Open and close the Upper Exit Assembly to make sure it moves smoothly.

## RRP 9.103 Full Stack Sensor (PL10.2.21)

---

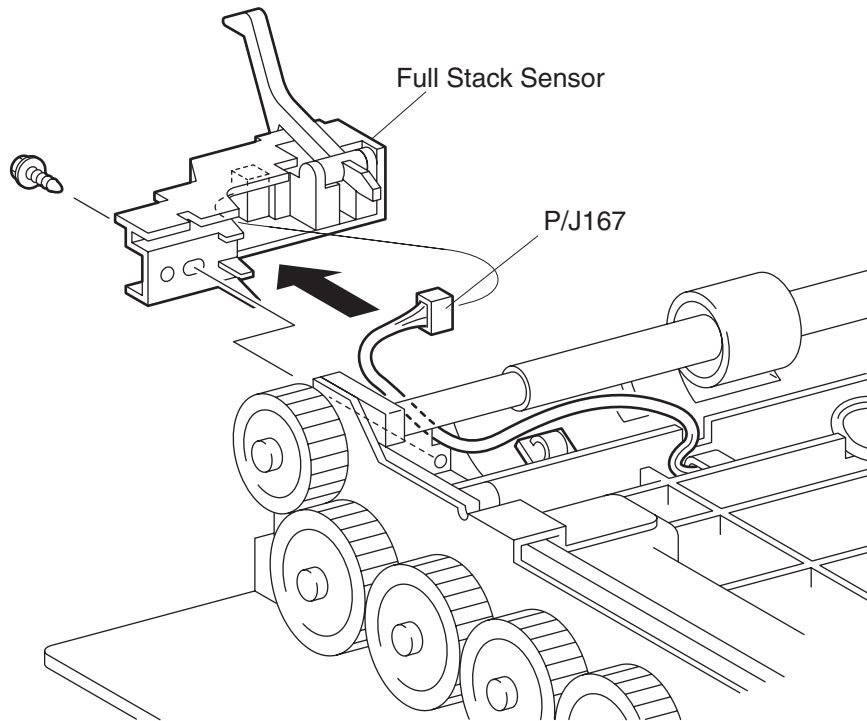

RS2024XB

RS2024XB

## **RRP 9.103 Full Stack Sensor (PL10.2.21)**

---

### **Removal**

1. Remove the Lower Exit Assembly (RRP 9.101).
2. Remove the screw securing the Full Stack Sensor to the Lower Exit Assembly.
3. Release the Full Stack Sensor wire harness from the wire clamp.
4. Disconnect P/J167 from the Sensor and remove the Sensor.

### **Replacement**

1. Reconnect P/J167 to the Full Stack Sensor.
2. Route the Full Stack Sensor wire harness through the wire clamp.
3. Reinstall the Full Stack Sensor onto the Lower Exit Assembly and use one screw to secure the Sensor.
4. Reinstall the Lower Exit Assembly (RRP 9.101).

## RRP 9.104 Exit-2 Roll Assembly (PL10.2.5)

---

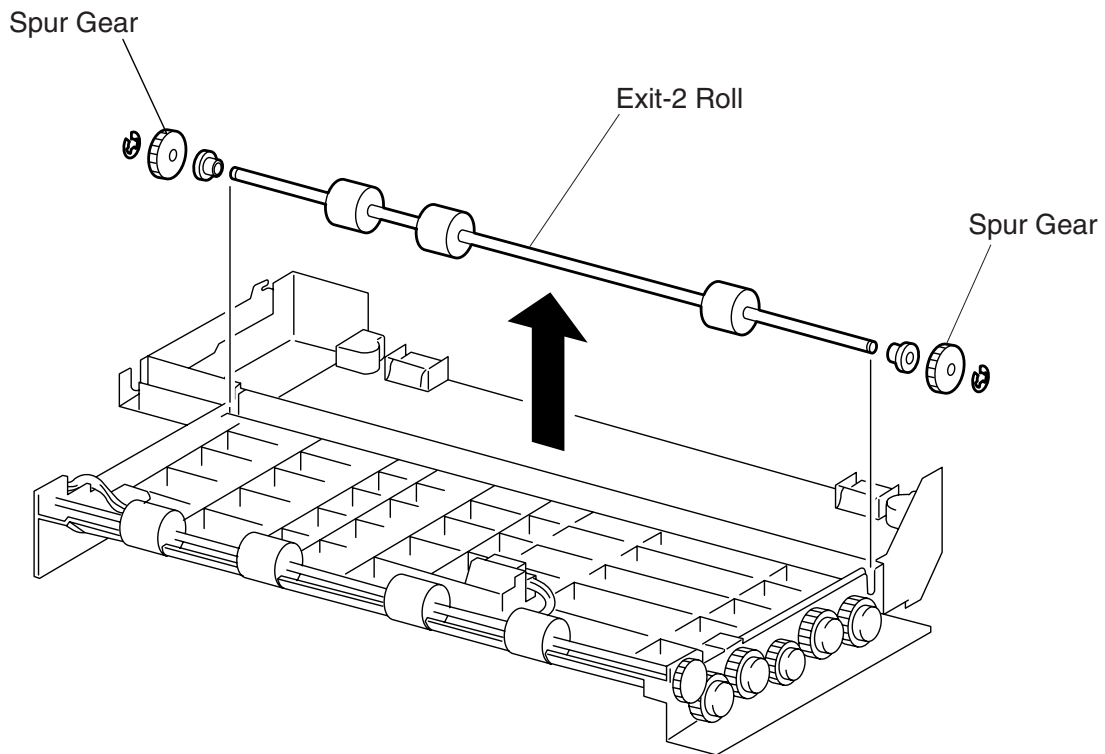

RS1098XB

RS1098XB

## **RRP 9.104 Exit-2 Roll Assembly (PL10.2.5)**

---

### **Removal**

1. Remove the Lower Exit Assembly (RRP 9.101).
2. Place the Lower Exit Assembly on a flat and stable work surface.
3. Remove the E ring securing the Spur Gear to the front of the Exit-2 Roll Shaft and remove the Gear.
4. Remove the E ring securing the Spur Gear to the rear of the Exit-2 Roll Shaft and remove the Gear.
5. Slide the Front and Rear Bearings off of the Exit-2 Roll Shaft.
6. Remove the Exit-2 Roll Assembly from the Lower Exit Assembly.

### **Replacement**

1. Position the Exit-2 Roll Assembly so the three rubber rollers line up with the indentations in the slot in the Lower Exit Assembly.
2. Reinstall the Exit-2 Roll Assembly into the slot in the Lower Exit Assembly.
3. Slide the Front and Rear Bearings onto the Exit-2 Roll Shaft and push the Bearings into the notches in the Lower Exit Assembly.
4. Slide a Spur Gear onto the front of the Exit-2 Roll Shaft and use an E ring to secure the Gear to the Shaft.
5. Slide a Spur Gear onto the rear of the Exit-2 Roll Shaft and use an E ring to secure the Gear to the Shaft.
6. Reinstall the Lower Exit Assembly (RRP 9.101).

## RRP 9.105 Exit-3 Roll Assembly (PL10.2.7)

---

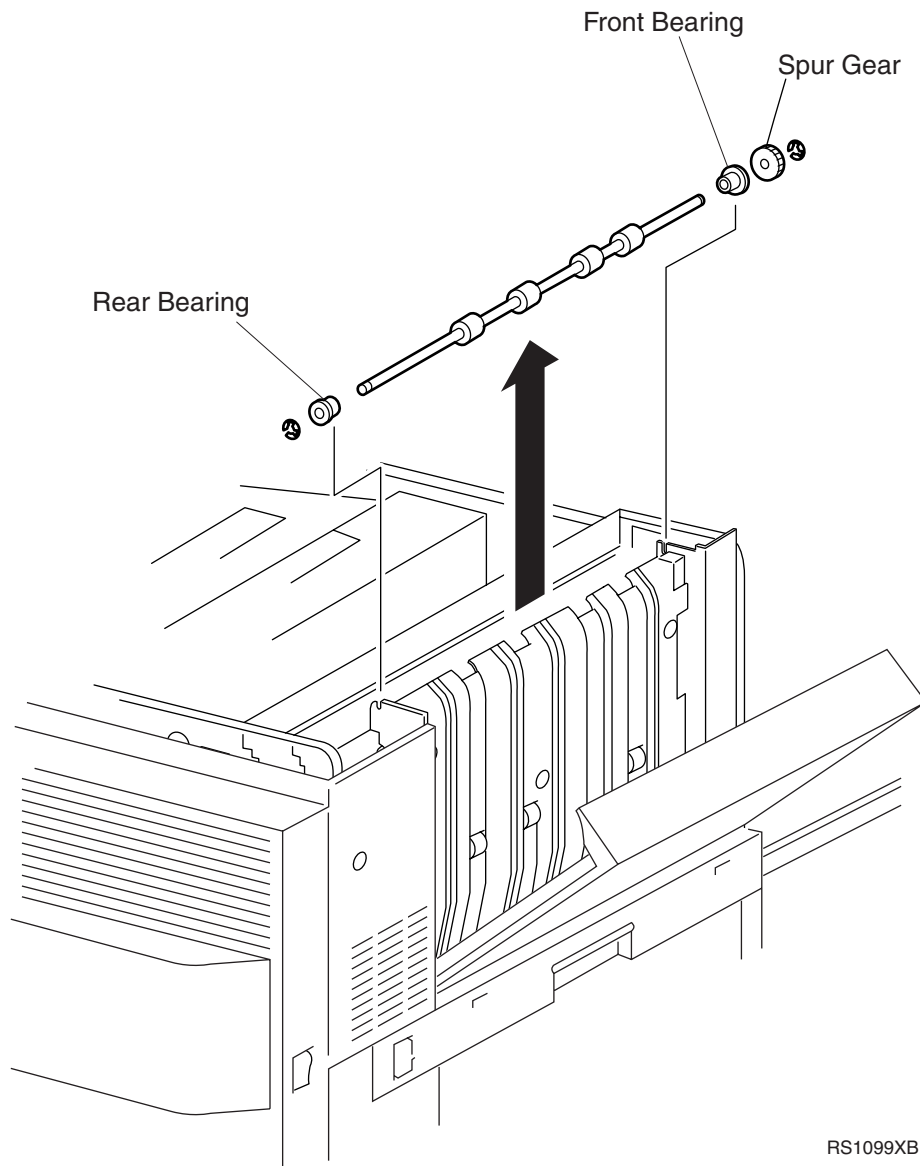

RS1099XB

## **RRP 9.105 Exit-3 Roll Assembly (PL10.2.7)**

---

### **Removal**

1. Remove the Top Cover (RRP 9.3).
2. Open the Lower Exit Assembly.
3. Remove the E ring securing the Spur Gear to the front of the Exit-3 Roll Shaft and remove the Gear.
4. Remove the E ring securing the Exit-3 Roll Shaft to the rear of the Lower Exit Assembly.
5. Slide the Front and Rear Bearings off of the Exit-3 Roll Shaft.
6. Remove the Exit-3 Roll Assembly from the Lower Exit Assembly.

### **Replacement**

1. Position the Exit-3 Roll Assembly so the four rubber rollers line up with the indentations in the Lower Exit Assembly.
2. Reinstall the Exit-3 Roll Assembly into the slot in the Lower Exit Assembly.
3. Slide the Front and Rear Bearings onto the Exit-3 Roll Shaft and push the Bearings into the notches in the Lower Exit Assembly.
4. Slide a Spur Gear onto the front of the Exit-3 Roll Shaft and use an E ring to secure the Gear to the Shaft.
5. Use an E ring to secure the Exit-3 Roll Shaft to the front of the Lower Exit Assembly.
6. Reinstall the Top Cover (RRP 9.3).

## RRP 9.106 Top Exit Sensor (PL10.2.12)

---

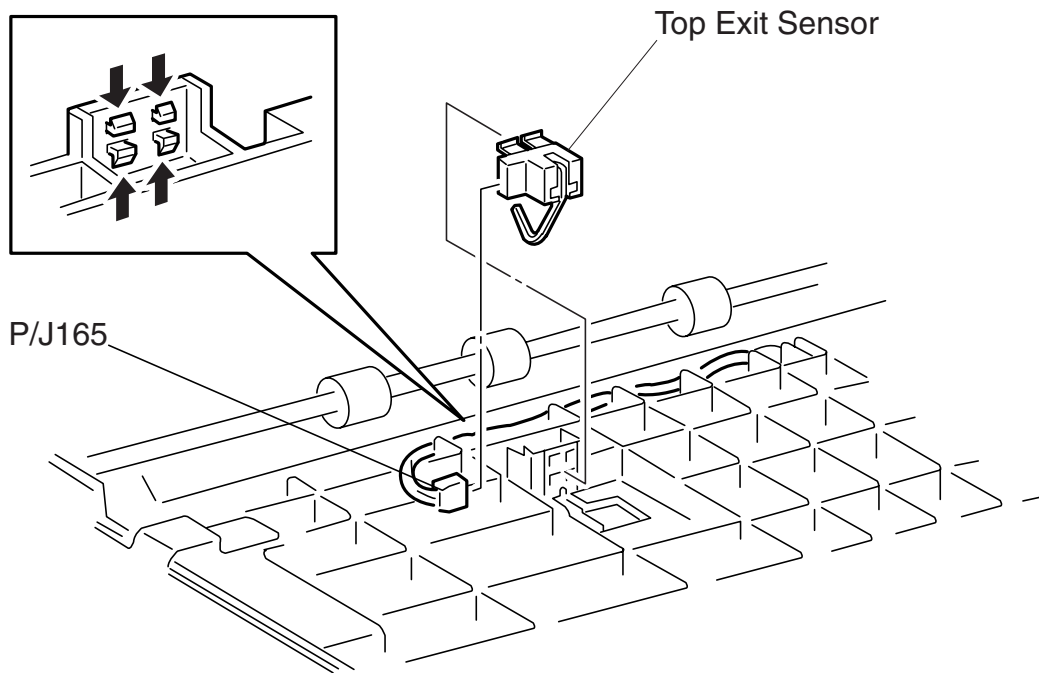

RS2000XB

RS2000XB



## **RRP 9.106 Top Exit Sensor (PL10.2.12)**

---

### **Removal**

1. Remove the Lower Exit Assembly (RRP 9.101).
2. Squeeze the four latches securing the Top Exit Sensor to the Lower Exit Assembly and remove the Sensor.

### **Replacement**

1. Slide the Top Exit Sensor Actuator through the slot in the Assembly.
2. Press the Sensor against the Lower Exit Assembly until the latches snap into place.
3. Make sure the Actuator moves freely.
4. Reinstall the Lower Exit Assembly (RRP 9.101).

## RRP 9.107 Exit Chute Switch (PL10.2.13)

---

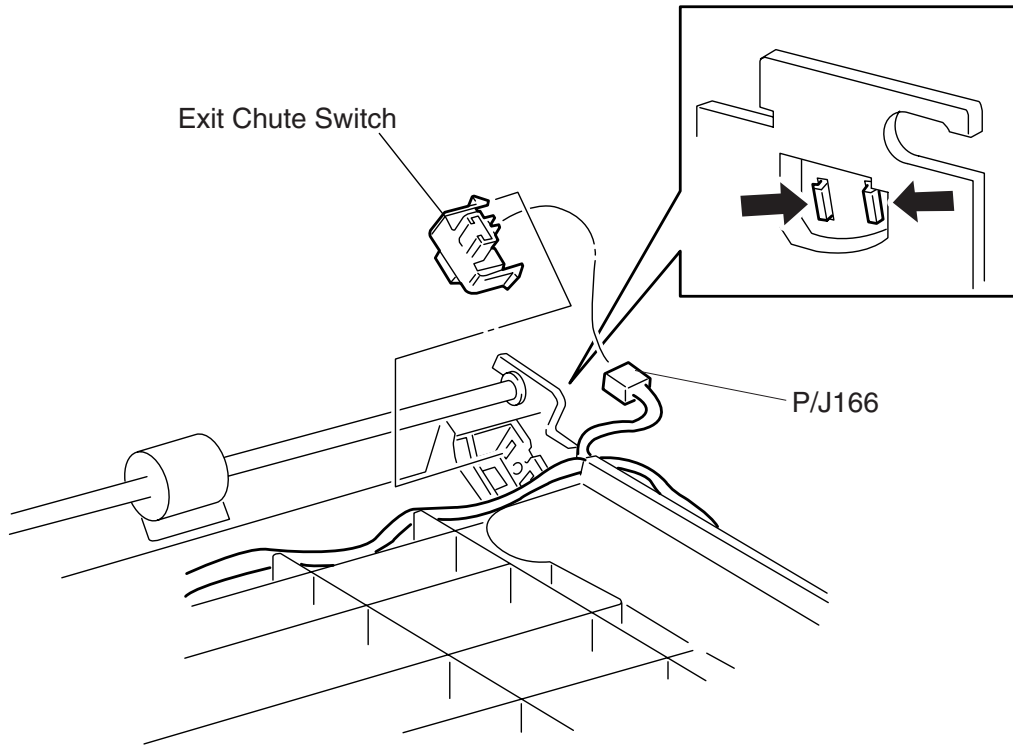

RS2001XB

RS2001XB

## **RRP 9.107 Exit Chute Switch (PL10.2.13)**

---

### **Removal**

1. Remove the Lower Exit Assembly (RRP 9.101).
2. Squeeze the latches holding the Exit Chute Switch to the Lower Exit Assembly and remove the Switch.

### **Replacement**

1. Position the Exit Chute Switch against the Lower Exit Assembly.
2. Line up the positioning pin and the two latches on the Sensor with the three holes in the Lower Exit Assembly.
3. Press the Sensor against the Assembly until the latches snap into place.
4. Reinstall the Lower Exit Assembly (RRP 9.101).

## RRP 9.108 Fuser Fan (PL10.2.15)

---

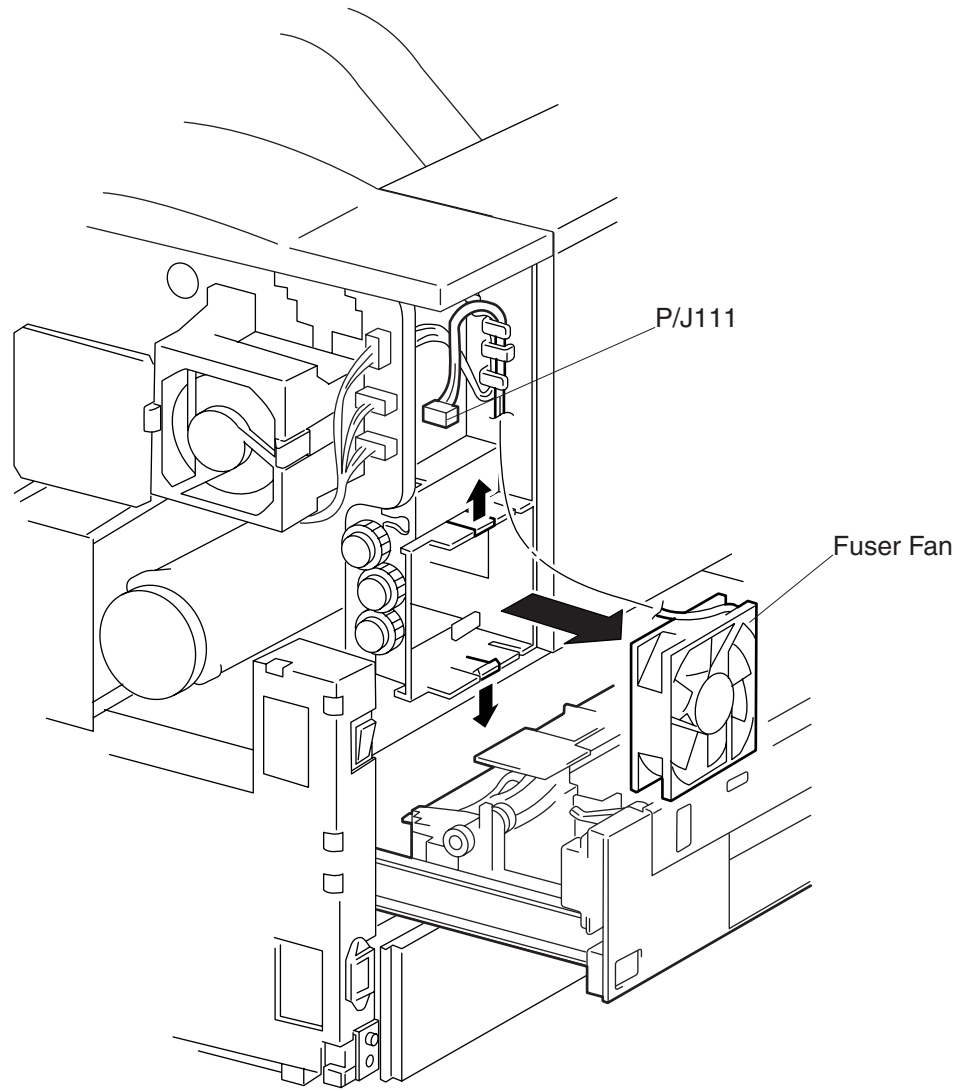

RS2002XB

RS2002XB

## **RRP 9.108 Fuser Fan (PL10.2.15)**

---

### **Removal**

1. Remove the Rear Cover (RRP 9.4).
2. Disconnect P/J 111 from the P/J near the top rear of the Lower Exit Assembly.
3. Spread the two latches securing the Fuser Fan to the Lower Exit Assembly and pull the Fan out of the Assembly.

### **Replacement**

1. Position the Fuser Fan so the label faces out and the wires exit the Fan at the top right.
2. Spread the two latches on the Lower Exit Assembly and push the Fuser Fan into the Assembly. The latches lock the Fan into place in the Lower Exit Assembly.
3. Reconnect P/J 111 to the P/J near the top rear of the Lower Exit Assembly.
4. Reinstall the Rear Cover (RRP 9.4).

## RRP 9.109 Paper Handling Drive Assembly (PL11.1.1)

---

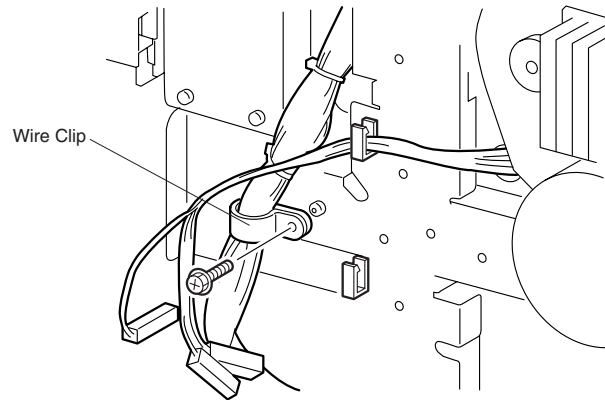

Figure 1

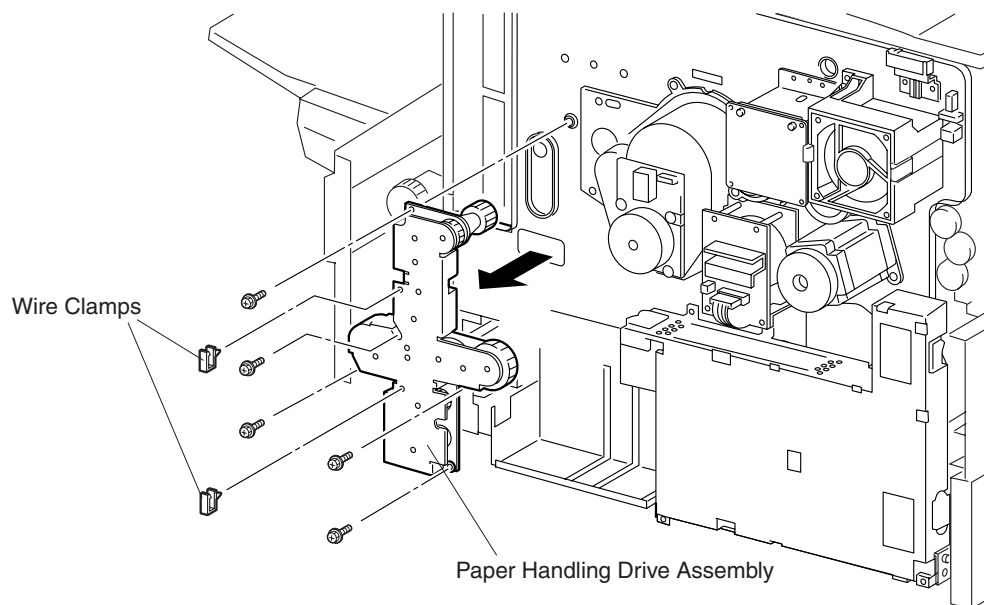

Figure 2

RS2003XB

RS2003XB

## **RRP 9.109 Paper Handling Drive Assembly (PL11.1.1)**

---

### **Removal**

1. Remove the High Voltage Power Supply (RRP 9.120).
2. Slide the Main Paper Handling Assembly out of the printer.
3. Remove the screw securing the wire clip to the Paper Handling Drive Assembly and move the clip and harness out of the way (Figure 1).
4. Remove the five screws securing the Paper Handling Drive Assembly to the printer frame and remove the Assembly (Figure 2).
5. Remove the two wire clamps from the Drive Assembly.

### **Replacement**

1. Reinstall the two wire clamps onto the Paper Handling Drive Assembly.
2. Position the Paper Handling Drive Assembly against the printer frame so the single gear fits through the cutout at the top of the frame.
3. Press the Paper Handling Drive Assembly against the printer frame so all of the gears fit through the cutouts and the five screw holes in the Assembly line up with the five screw holes in the frame.
4. Use five screws to secure the Paper Handling Drive Assembly to the printer frame.
5. Reinstall the wire clip and attached wire harness to the Paper Handling Drive Assembly and use one screw to secure the clip to the Assembly.
6. Slide the Main Paper Handling Assembly into the printer.
7. Reinstall the High Voltage Power Supply (RRP 9.120).

## RRP 9.110 Fuser Drive Assembly (PL11.1.2)

---

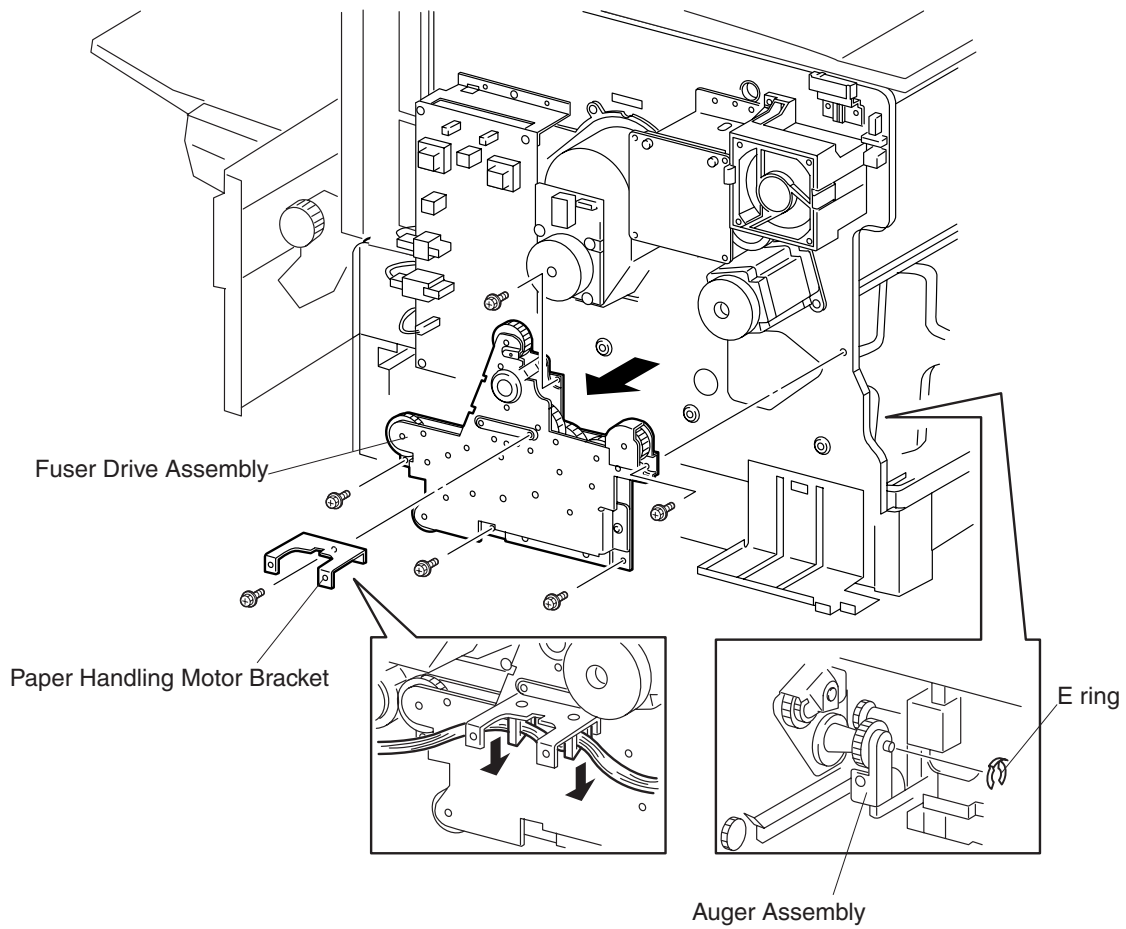

RS2004XB

RS2004XB



## **RRP 9.110 Fuser Drive Assembly (PL11.1.2)**

---

### **Removal**

1. Slide out the Fuser Assembly (RRP 9.80).
2. Remove the Low Voltage Power Supply (RRP 9.119).
3. Remove the Paper Handling Motor Assembly (RRP 9.111).
4. Remove the wire harness from the Paper Handling Motor Bracket.
5. Remove the screw securing the Paper Handling Motor Bracket to the Fuser Drive Assembly and remove the Bracket.
6. Reach inside the empty Fuser Assembly cavity and remove the E ring securing the Fuser Drive Gear shaft to the Auger Drive Assembly.
7. Remove the five screws securing the Fuser Drive Assembly to the printer frame and remove the Assembly.

### **Replacement**

1. Reinstall the Fuser Drive Assembly onto the printer frame by inserting the Drive Gears into the cutout in the printer frame, and inserting the Fuser Drive Gear shaft into the hole in the Auger Drive Assembly.
2. Line up the five screw holes in the Fuser Drive Assembly with the five screw holes in the printer frame and use five screws to secure the Fuser Drive Assembly to the frame.
3. Reach inside the empty Fuser Assembly cavity and reinstall the E ring securing the Fuser Drive Gear shaft to the Auger Drive Assembly.
4. Reinstall the Paper Handling Motor Bracket onto the Fuser Drive Assembly and use one screw to secure the Bracket to the Assembly.
5. Reinstall the wire harness under the Paper Handling Motor Bracket.
6. Reinstall the Paper Handling Motor Assembly (RRP 9.111).
7. Reinstall the Low Voltage Power Supply (RRP 9.119).
8. Reinstall the Fuser Assembly (RRP 9.80).

## RRP 9.111 Paper Handling Motor Assembly (PL11.1.3)

---

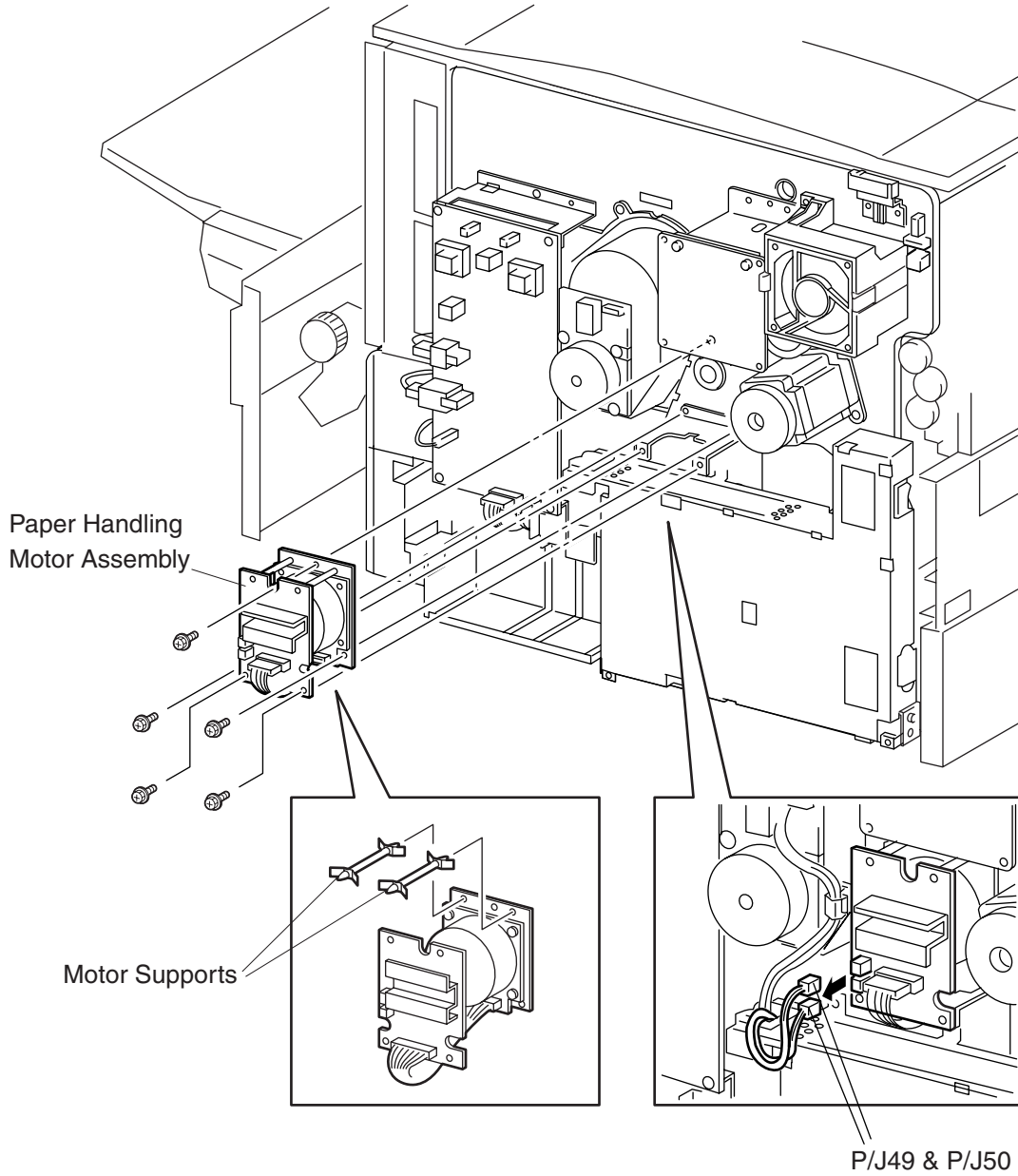

RS2005XB

RS2005XB

## **RRP 9.111 Paper Handling Motor Assembly (PL11.1.3)**

---

### **Removal**

1. Remove the Rear Cover (RRP 9.4).
2. Disconnect P/J 49 and P/J 50 from the Paper Handling Motor PWB.
3. Remove the five screws securing the Paper Handling Motor Assembly to the Fuser Drive Assembly and remove the Motor Assembly.
4. Remove the two Motor Supports.

### **Replacement**

1. Reinstall the two Motor Supports between the Motor and the Motor PWB.
2. Reinstall the Paper Handling Motor Assembly onto the Fuser Drive Assembly by inserting the motor shaft into the cutout in the Fuser Drive Assembly.
3. Line up the five screw holes in the Motor Assembly with the four screw holes in the Fuser Drive Assembly.
4. Use four screws to secure the Paper Handling Motor Assembly to the Fuser Drive Assembly.
5. Reconnect P/J 49 and P/J 50 to the Paper Handling Motor PWB.
6. Reinstall the Rear Cover (RRP 9.4).

## RRP 9.112 Process Motor Assembly (PL11.1.12)

---

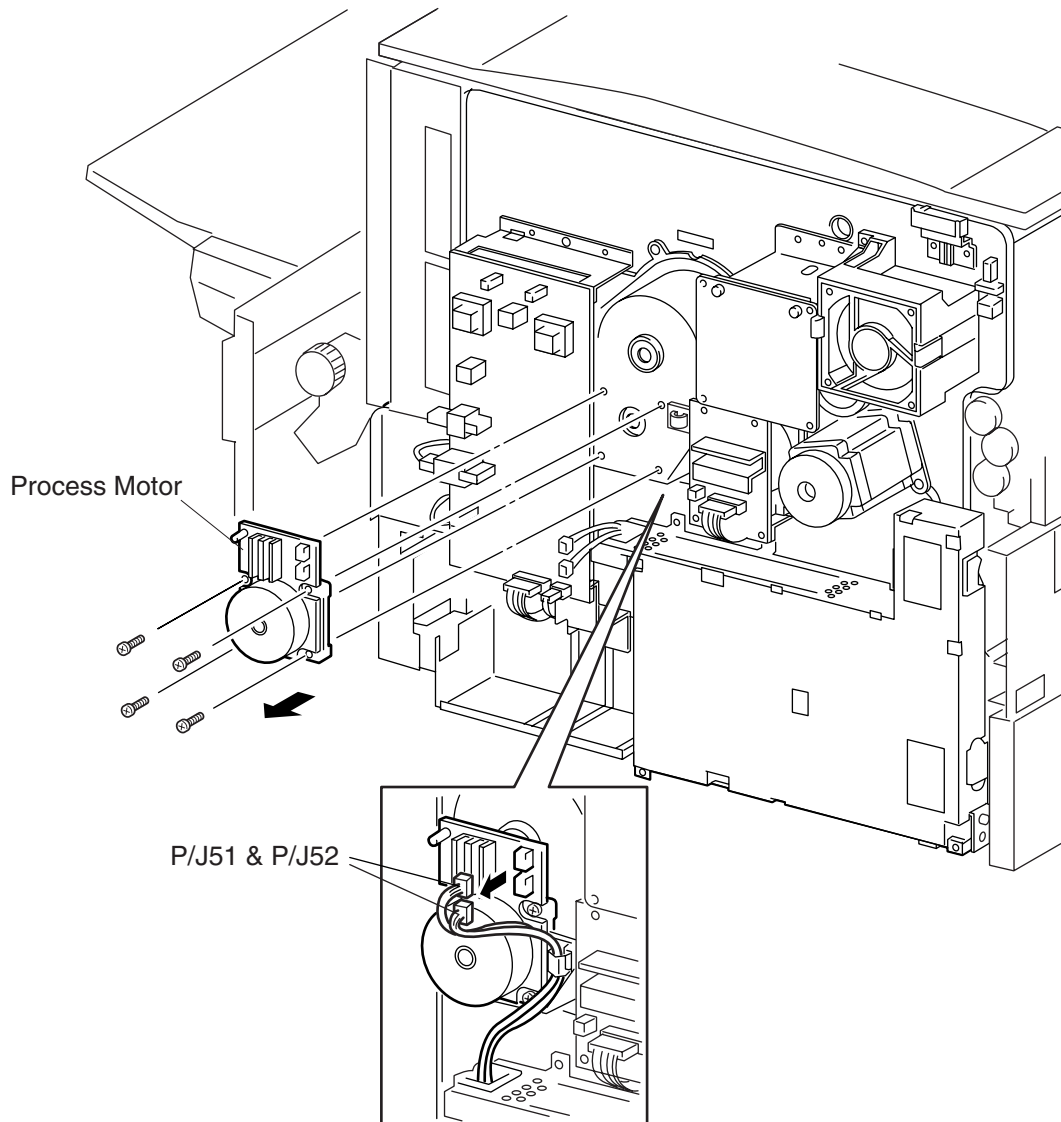

RS2006XB

RS2006XB

## **RRP 9.112 Process Motor Assembly (PL11.1.12)**

---

### **Removal**

1. Remove the Rear Cover (RRP 9.4).
2. Disconnect P/J 51 and P/J 52 leading to the Process Motor PWB.
3. Remove the four screws securing the Process Motor Assembly to the Process Drive Assembly and remove the Motor Assembly.

### **Replacement**

1. Reinstall the Process Motor Assembly onto the Process Drive Assembly.
2. Line up the four screw holes in the Motor Assembly with the four screw holes in the Process Drive Assembly.
3. Use four screws to secure the Motor Assembly to the Drive Assembly.
4. Reconnect P/J 51 and P/J 52 to the Process Motor PWB.
5. Reinstall the Rear Cover (RRP 9.4).

## RRP 9.113 Process Drive Assembly (PL11.1.10)

---

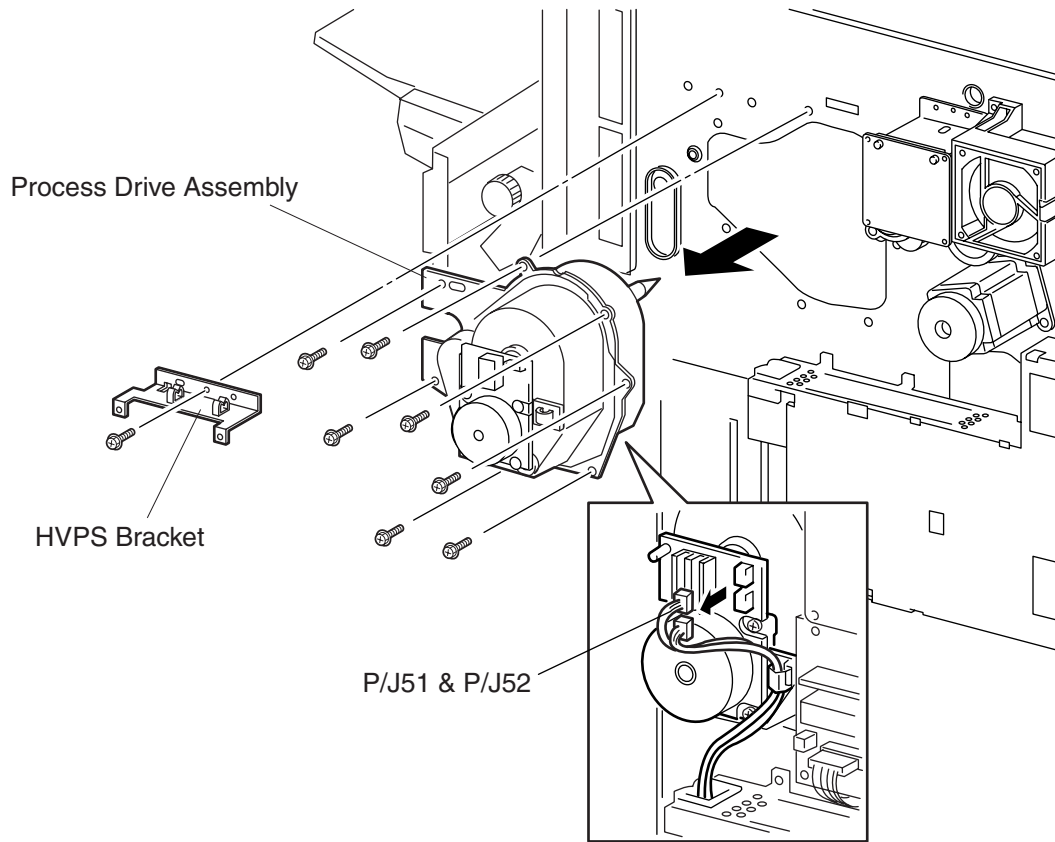

RS2007XB

RS2007XB

## **RRP 9.113 Process Drive Assembly (PL11.1.10)**

---

### **Removal**

1. Remove the Xerographic Cartridge (RRP 9.48).
2. Remove the Paper Handling Drive Assembly (RRP 9.109).
3. Disconnect P/J 51 and P/J 52 leading to the Process Motor PWB and unhook the wires from the wire harness clip that is attached to the Process Drive Assembly.
4. Remove the screw securing the HVPS Bracket and move the Bracket out of the way.
5. Hold on to the Process Drive Assembly, it is heavy, while you remove the seven screws securing the Assembly to the printer frame and carefully pull the Assembly away from the frame.

### **Replacement**

1. Reinstall the Process Drive Assembly onto the printer frame, making sure you line up the positioning slot at the top left side of the Assembly with the positioning pin on the printer frame.
2. Use seven screws to secure the Process Drive Assembly to the printer frame.
3. Reinstall the HVPS Bracket to the printer frame and use one screw to secure the Bracket.
4. Reconnect P/J 51 and P/J 52 leading to the Process Motor PWB and hook the wires under the wire harness clip that is attached to the Process Drive Assembly.
5. Reinstall the Paper Handling Drive Assembly (RRP 9.109).
6. Reinstall the Xerographic Cartridge (RRP 9.48).

## RRP 9.114 Rotary Motor Assembly (PL11.1.20)

---

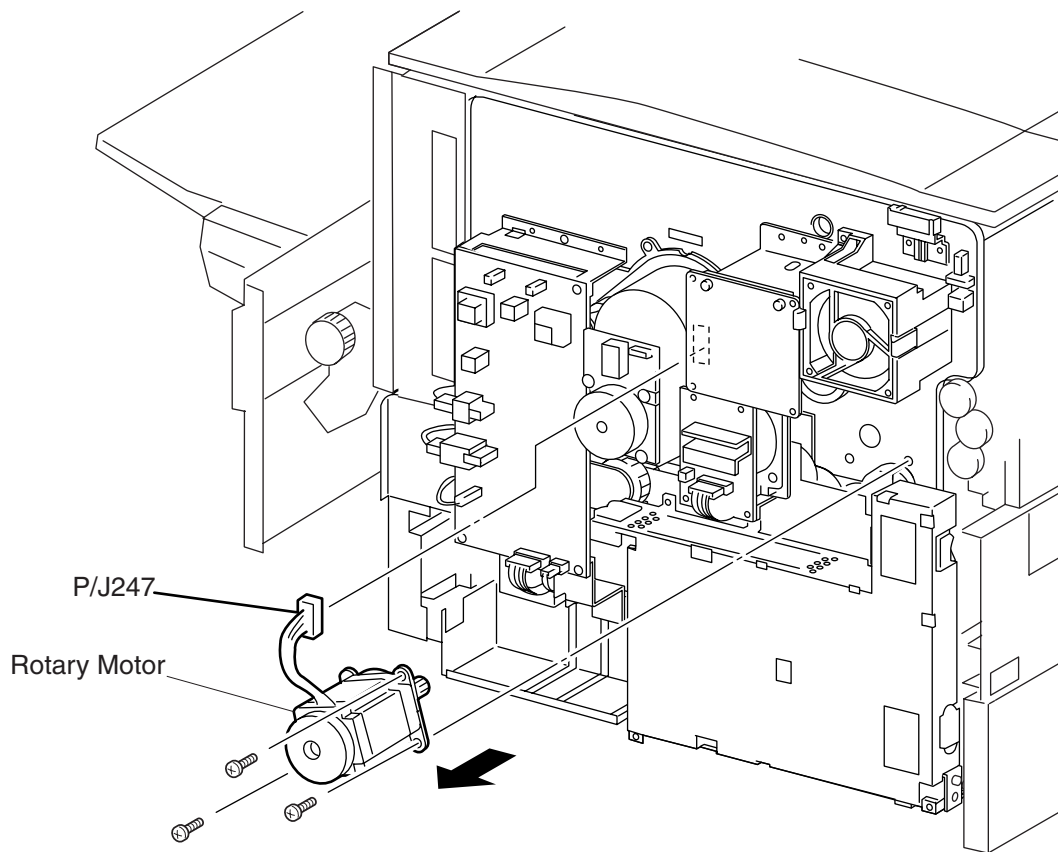

RS2008XB

RS2008XB



## **RRP 9.114 Rotary Motor Assembly (PL11.1.20)**

---

### **Removal**

1. Remove the Rear Cover (RRP 9.4).
2. Disconnect P/J 247 from the Rotary Motor PWB.
3. Remove the three screws securing the Rotary Motor Assembly to the printer frame and remove the Motor.

### **Replacement**

1. Position the Rotary Motor Assembly so the wires are at the top.
2. Reinstall the Rotary Motor Assembly onto the printer frame, repositioning the Motor so the two positioning tabs on the Motor fit into the two positioning holes in the frame.
3. Use three screws, top right, bottom right, and bottom left, to secure the Rotary Motor Assembly to the printer frame.
4. Reconnect P/J 247 to the Rotary Motor PWB.
5. Reinstall the Rear Cover (RRP 9.4).

## RRP 9.115 Rotary Motor PWB (PL11.1.21)

---

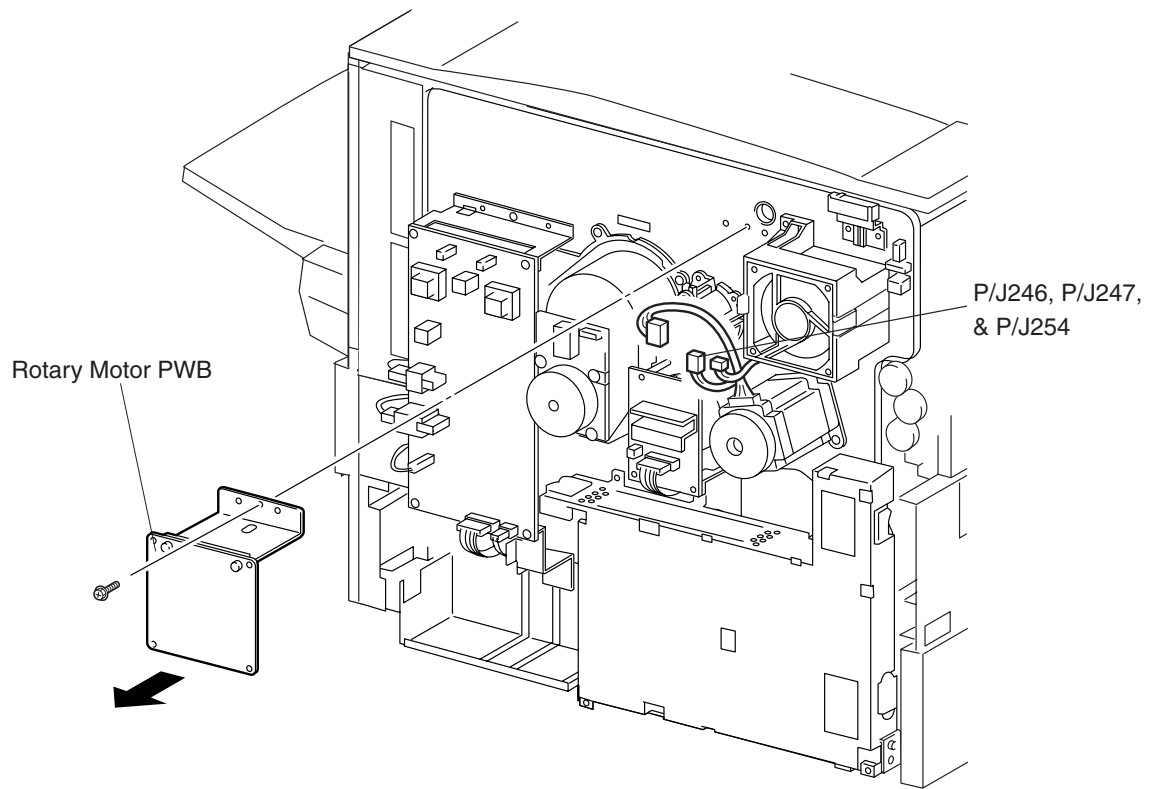

RS2009XB

RS2009XB

## **RRP 9.115 Rotary Motor PWB (PL11.1.21)**

---

### **Removal**

1. Remove the Rear Cover (RRP 9.4).
2. Remove P/J 246, P/J 247, and P/J 254 from the Rotary Motor PWB.
3. Remove the screw securing the Rotary Motor PWB to the printer frame and remove the PWB.

### **Replacement**

1. Reinstall the Rotary Motor PWB onto the printer frame.
2. Reposition the PWB so the two positioning holes and the screw hole in the PWB line up with the two positioning tabs and screw hole in the printer frame.
3. Use one screw to secure the Rotary Motor PWB to the printer frame.
4. Reconnect P/J 246, P/J 247, and P/J 254 to the Rotary Motor PWB.
5. Reinstall the Rear Cover (RRP 9.4).

## RRP 9.116 Dispense Motor Assembly (PL11.1.22)

---

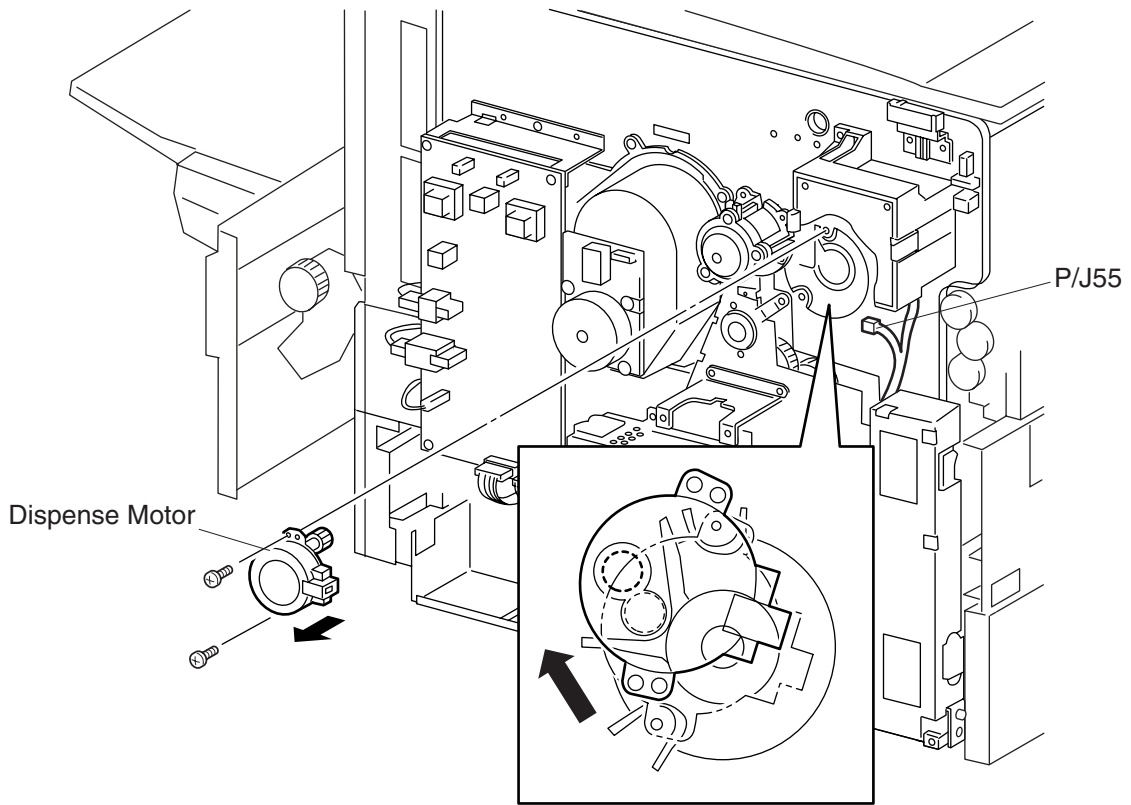

RS2010XB

RS2010XB

## **RRP 9.116 Dispense Motor Assembly (PL11.1.22)**

---

### **Removal**

1. Remove the Rotary Motor PWB (RRP 9.115).
2. Remove the two screws securing the Dispense Motor to the printer frame.
3. Slide the Dispense Motor up and slightly to the left to free the Motor shaft gear from the frame, and remove the Motor (inset).
4. Disconnect P/J 55 from the Dispense Motor.

### **Replacement**

1. Reconnect P/J 55 to the Dispense Motor.
2. Position the Dispense Motor so the P/J connector is facing to the right.
3. Reinstall the Dispense Motor by inserting the Motor shaft gear into the large key slot then sliding the Motor down so the shaft rests in the large key slot (inset).
4. Line up the two screw holes in the Motor with the two screw holes in the printer frame.
5. Use two screws to secure the Motor to the frame.
6. Reinstall the Rotary Motor PWB (RRP 9.115).

## RRP 9.117 Developer Clutch Assembly (PL11.1.23)

---

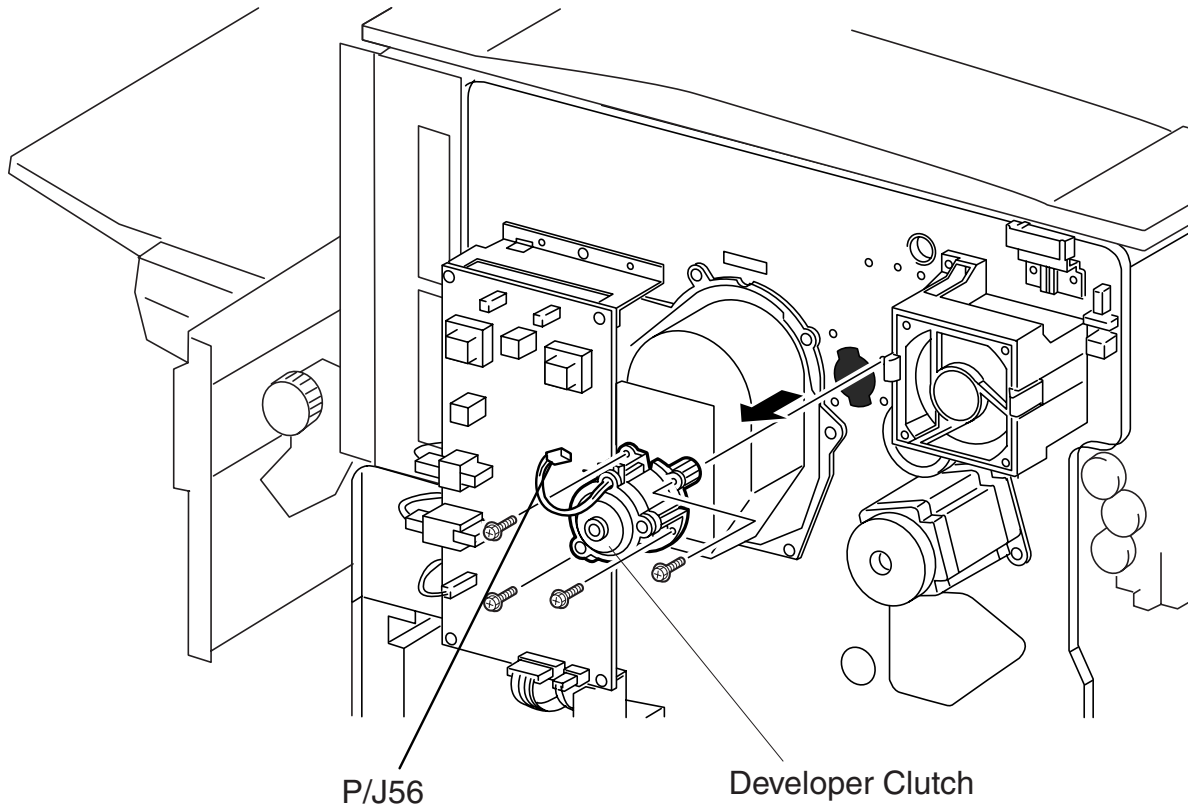

RS2011XC

RS2011XC

## **RRP 9.117 Developer Clutch Assembly (PL11.1.23)**

---

### **Removal**

1. Remove the Rotary Motor PWB (RRP 9.115).
2. Disconnect P/J 56 from the Developer Clutch.
3. Remove the Fuser Drive Assembly (RRP 9.110).
4. Remove the four screws securing the Developer Clutch to the printer frame and remove the Clutch.

### **Replacement**

1. Position the Developer Clutch Assembly so the wires are at the top of the Clutch.
2. Align the positioning keys on the Clutch with the cutouts in the frame and press the Clutch against the frame.
3. Line up the four screw holes in the Clutch with the four screw holes in the frame.
4. Use four screws to secure the Developer Clutch Assembly to the printer frame.
5. Reinstall the Fuser Drive Assembly (RRP 9.110).
6. Reconnect P/J 56 to the Developer Clutch.
7. Reinstall the Rotary Motor PWB (RRP 9.115).

## RRP 9.118 Developer Tie Plate (PL12.1.4)

---

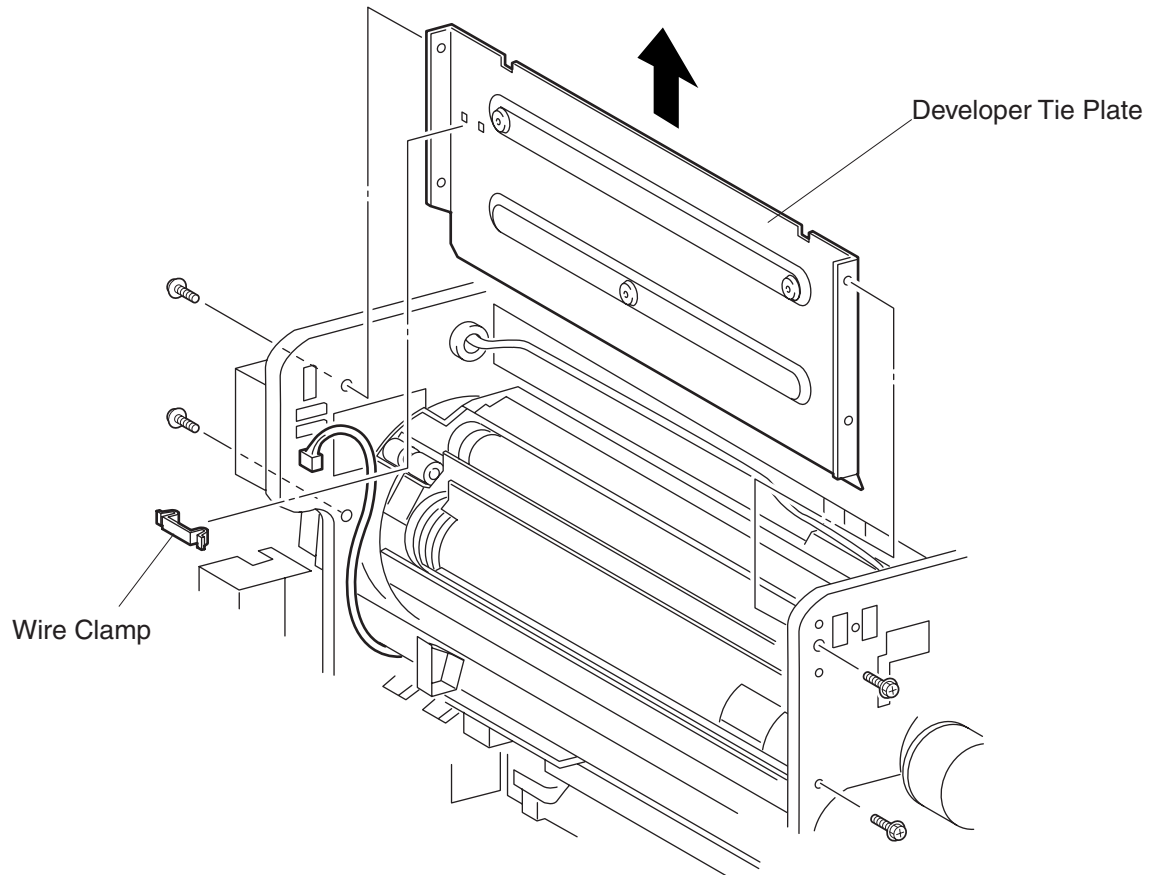

RS2012XB

RS2012XB



## **RRP 9.118 Developer Tie Plate (PL12.1.4)**

---

### **Removal**

1. Remove the Lower Exit Assembly (RRP 9.101).
2. Remove the Rear Cover (RRP 9.4).
3. Remove the Inner Cover (RRP 9.2).
4. Remove the wire and Wire Clamp from the Developer Tie Plate.
5. Remove the two screws securing the Developer Tie Plate to the rear of the printer frame.
6. Remove the two screws securing the Developer Tie Plate to the front of the printer frame.
7. Slide the Tie Plate up and out of the printer frame.

### **Replacement**

1. Position the Developer Tie Plate as shown.
2. Slide the Tie Plate down into position, behind the P/J connectors that are located on the rear of the printer frame.
3. Use two screws to secure the Developer Tie Plate to the front of the printer frame.
4. Use two screws to secure the Developer Tie Plate to the rear of the printer frame.
5. Reinstall the Wire Clamp and wire onto the Developer Tie Plate.
6. Reinstall the Inner Cover (RRP 9.2).
7. Reinstall the Rear Cover (RRP 9.4).
8. Reinstall the Lower Exit Assembly (RRP 9.101).

## RRP 9.119 Low Voltage Power Supply (LVPS) (PL13.1.1)

---

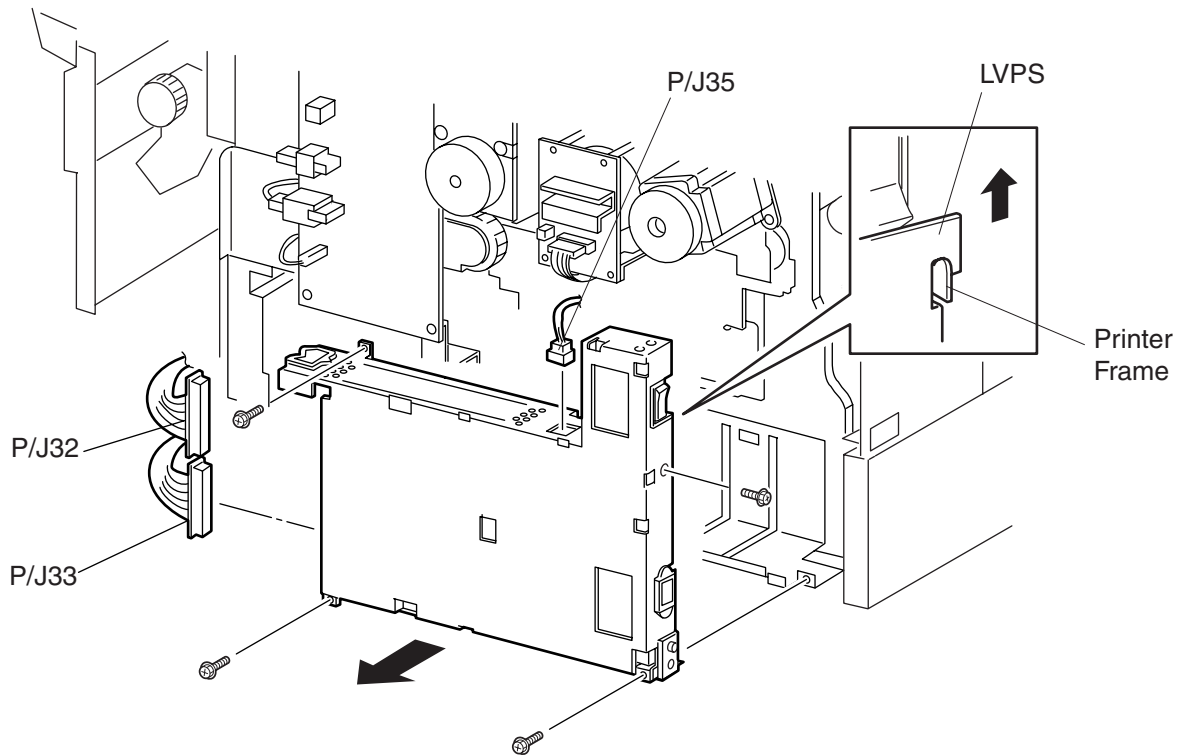

RS2013XB

RS2013XB

## **RRP 9.119 Low Voltage Power Supply (LVPS) (PL13.1.1)**

---

### **Removal**

1. Remove the Rear Cover (RRP 9.4).
2. Press in on the plug clip and disconnect P/J 35 from the top of the LVPS.
3. Press in on the plug clips and disconnect P/J 32 and P/J 33 from the LVPS.
4. Release the wire harness from the wire clip located at the top left of the LVPS.
5. Remove the four screws securing the LVPS to the printer frame - lift and remove the LVPS from the printer frame.

### **Replacement**

1. Move the wire harnesses out of the way and reinstall the LVPS onto the printer frame making sure you hook the rear of the LVPS over the tab on the printer frame (see inset).
2. Line up the four screw holes in the LVPS with the four screw holes in the printer frame.
3. Use four screws to secure the LVPS to the printer frame.
4. Reconnect P/J 32 and P/J 33 to the LVPS.  
The plug snaps into place.
5. Reconnect P/J 35 to the top of the LVPS.  
The plugs snap into place.
6. Reinstall the Rear Cover (RRP 9.4).

## RRP 9.120 High Voltage Power Supply (HVPS) (PL13.1.2)

---

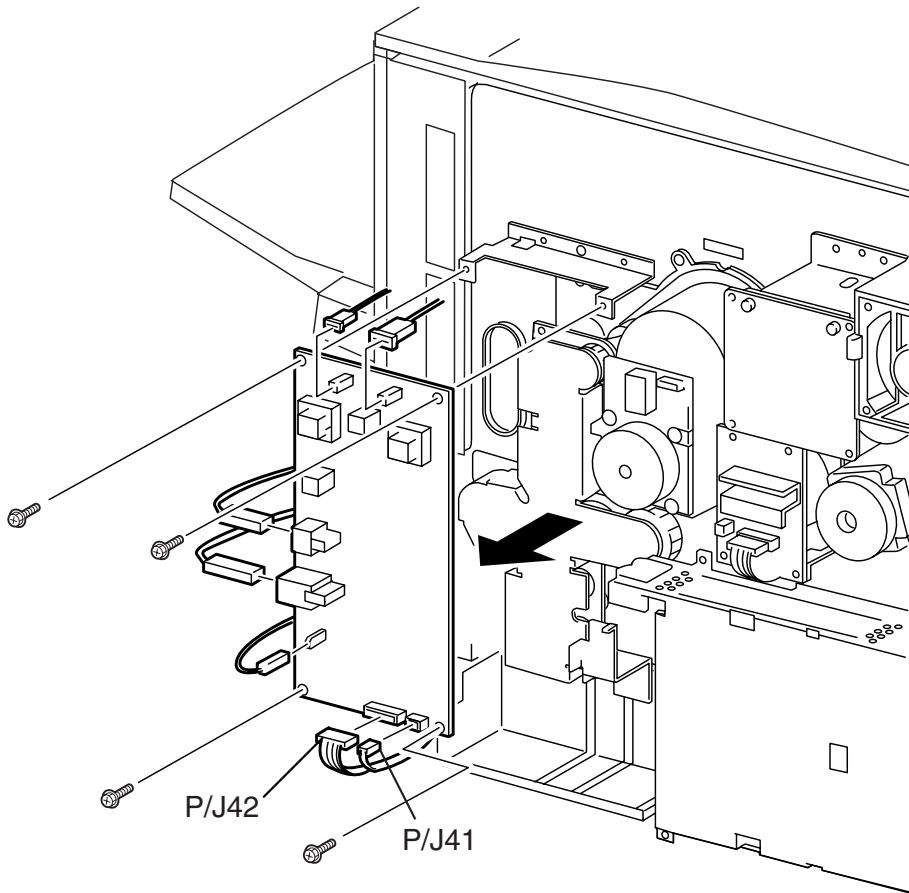

RS2014XB

RS2014XB

## **RRP 9.120 High Voltage Power Supply (HVPS) (PL13.1.2)**

---

### **Removal**

1. Remove the Rear Cover (RRP 9.4).
2. Disconnect P/J 41 and P/J 42 from the bottom of the HVPS.
3. Disconnect the five xerographic voltage P/Js from the HVPS.
4. Remove the four screws securing the HVPS to the HVPS Brackets and remove the HVPS.

### **Replacement**

1. Position the HVPS so xerographic connections A and C are at the top of the PWB.
2. Reinstall the HVPS onto the HVPS Brackets, making sure that none of the wire harnesses are trapped between the HVPS and the printer frame.
3. Use four screws to secure the HVPS to Brackets.
4. Reconnect the five xerographic voltage P/Js to the HVPS.
5. Reconnect P/J 41 and P/J 42 to the bottom of the HVPS.
6. Reinstall the Rear Cover (RRP 9.4).

## RRP 9.121 Top Cover Switch (PL13.1.3)

---

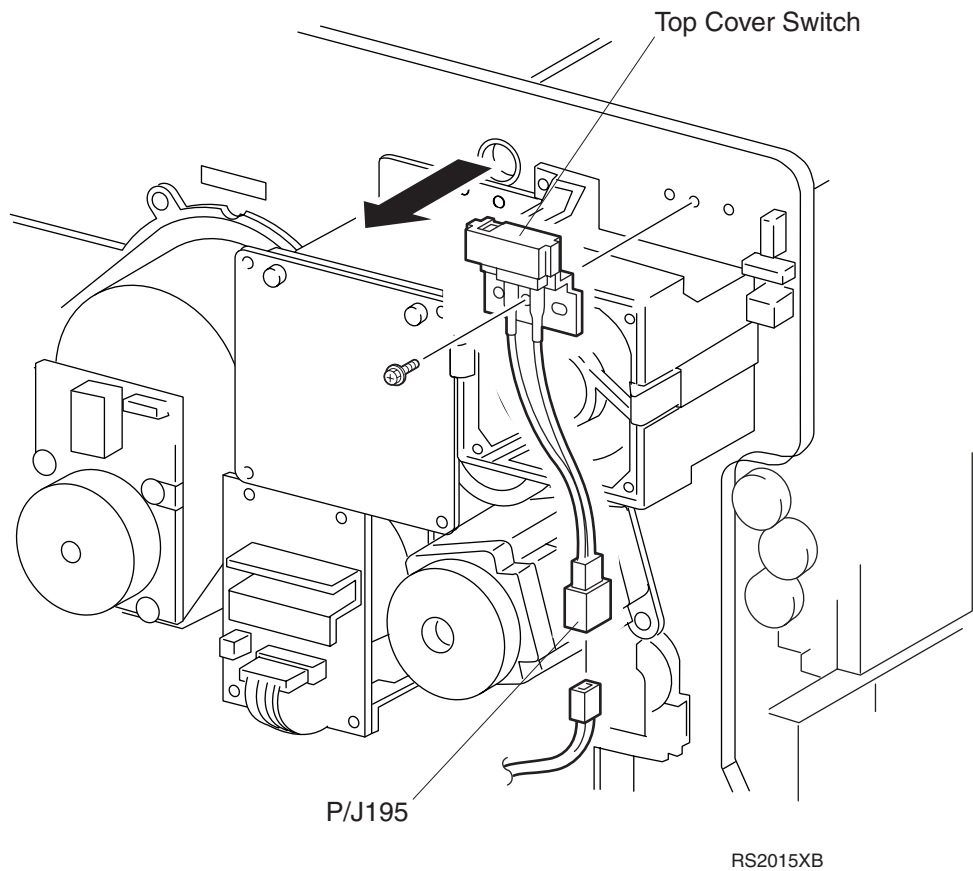

RS2015XB

## **RRP 9.121 Top Cover Switch (PL13.1.3)**

---

### **Removal**

1. Remove the Top Cover Assembly (RRP 9.3).
2. Disconnect P/J 195 from the Top Cover Switch.
3. Remove the screw securing the Top Cover Switch to the printer frame and remove the Switch.

### **Replacement**

1. Line up the two positioning holes and the screw hole in the Top Cover Switch with the two positioning tabs and the screw hole in the printer frame.
2. Use one screw to secure the Top Cover Switch to the printer frame.
3. Reconnect P/J 195 to the Top Cover Switch.
4. Reinstall the Top Cover Assembly (RRP 9.3).

## RRP 9.122 Developer Fan (PL13.1.5)

---

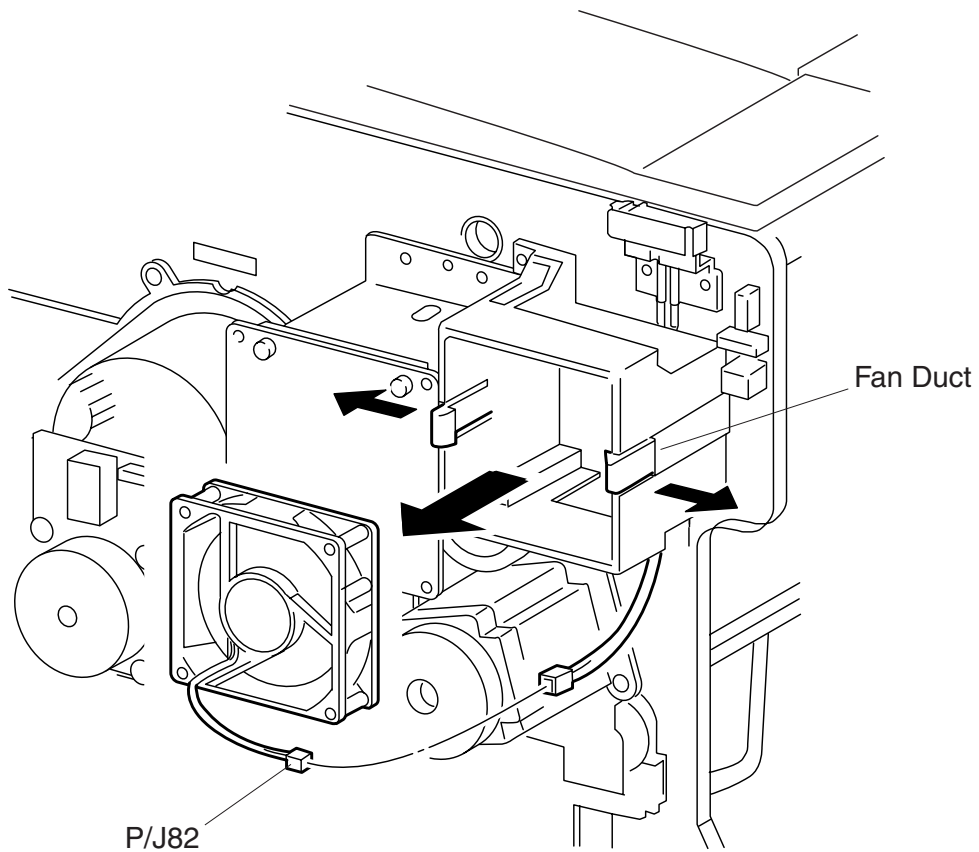

RS2016XB

RS2016XB



## **RRP 9.122 Developer Fan (PL13.1.5)**

---

### **Removal**

1. Remove the Rear Cover (RRP 9.4).
2. Disconnect P/J 82 from the Developer Fan.
3. Pull out on the two Fan latches as you press the Developer Fan out of the Fan Duct.

### **Replacement**

1. Position the Developer Fan against the Developer Fan Duct so the label on the Fan faces out and the Fan wires are next to the cutout that is located in the bottom of the Duct.
2. Pull out on the two Fan latches as you press the Developer Fan into the Fan Duct.  
The Fan snaps into place.
3. Reconnect P/J 82 to the Developer Fan.
4. Reinstall the Rear Cover (RRP 9.4).

## RRP 9.123 MCU PWB (PL13.2.1)

---

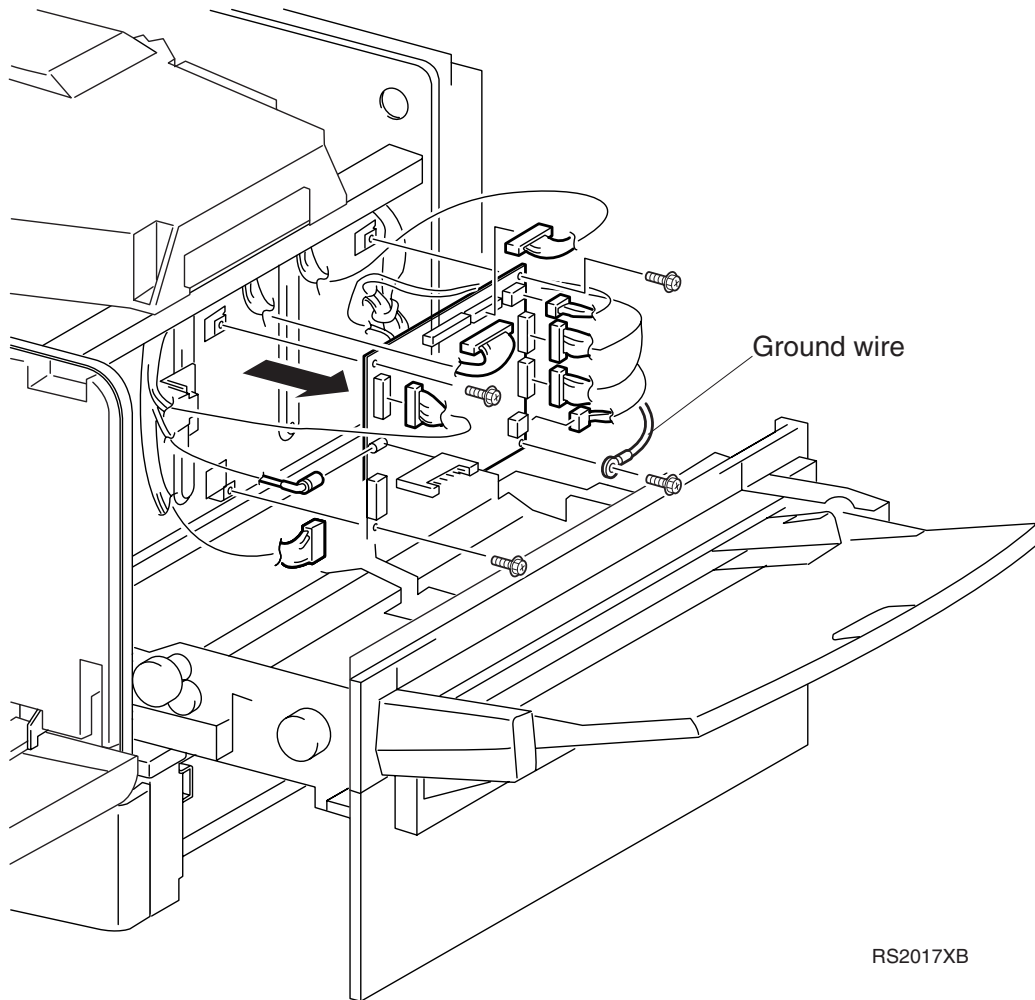

RS2017XB

RS2017XB

## RRP 9.123 MCU PWB (PL13.2.1)

---

### Removal

1. Read all of the Life Counter values stored on the MCU PWB (see Section 9) and write them down.
2. Remove the Controller Chassis Assembly (RRP 9.127).
3. Disconnect the two screws securing the Ground Wires to the PWB and remove the Wires.
4. Remove the two other screws securing the MCU PWB to the printer frame and remove the MCU PWB.



*Wear an electrostatic wrist strap and use caution when working with the MCU PWB. Static electricity can damage the sensitive electronics of the MCU PWB.*

*Handle the MCU PWB by the edges of the board. Never touch any of the ICs that are mounted on the PWB.*

### Replacement

1. Position the MCU PWB so the text printed on the PWB is right side up.
2. Reinstall the MCU PWB onto the printer frame.
3. Reinstall the Ground Wire onto the bottom right screw hole in the MCU PWB and use one screw to secure the Wire.
4. Reinstall the Ground Wire onto the top left screw hole in the MCU PWB and use one screw to secure the Wire.
5. Use two screws to finish secure the MCU PWB to the printer frame.
6. Reconnect the nine P/Js to the MCU PWB.
7. Reinstall the Controller Chassis Assembly (RRP 9.127).
8. Write all of the old Life Counter values onto the new MCU PWB (see Section 9).

## RRP 9.124 Front Cover Switch R (PL13.2.3)

---

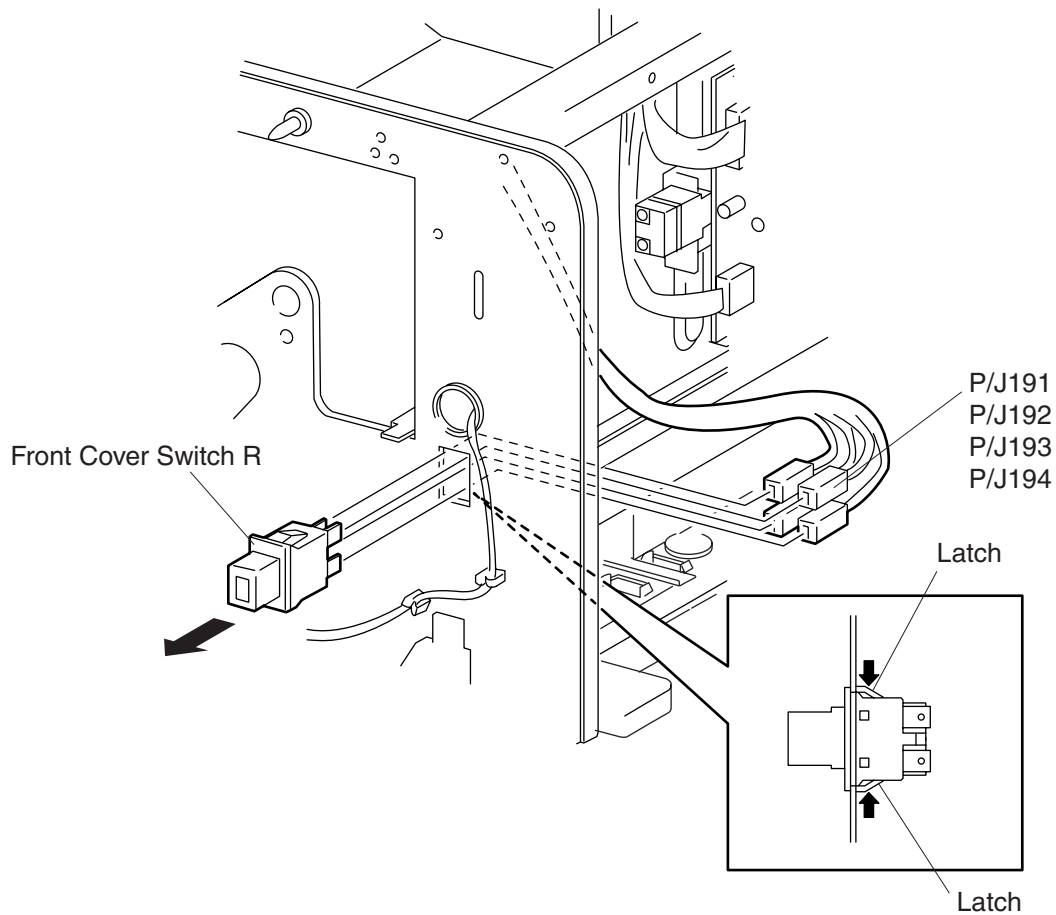

RS2018XB

RS2018XB

## RRP 9.124 Front Cover Switch R (PL13.2.3)

---

### Removal

1. Remove the Controller Chassis Assembly (RRP 9.127).
2. Disconnect the P/J191, P/J192, P/J193, and P/J194 from the Front Cover Switch R.

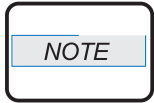

*Mark the wires for correct replacement.*

3. Squeeze the two latches on the side of the Front Cover Switch as you push the Switch out of the front of the printer frame.

### Replacement

1. Slide the Front Cover Switch into the cutout in the front of the printer frame.  
The latches snap into place.
2. Reconnect the P/J191, P/J192, P/J193, and P/J194 to the Front Cover Switch.
3. Reinstall the Controller Chassis Assembly (RRP 9.127).

## RRP 9.125 Front Cover Switch L (PL13.2.4)

---

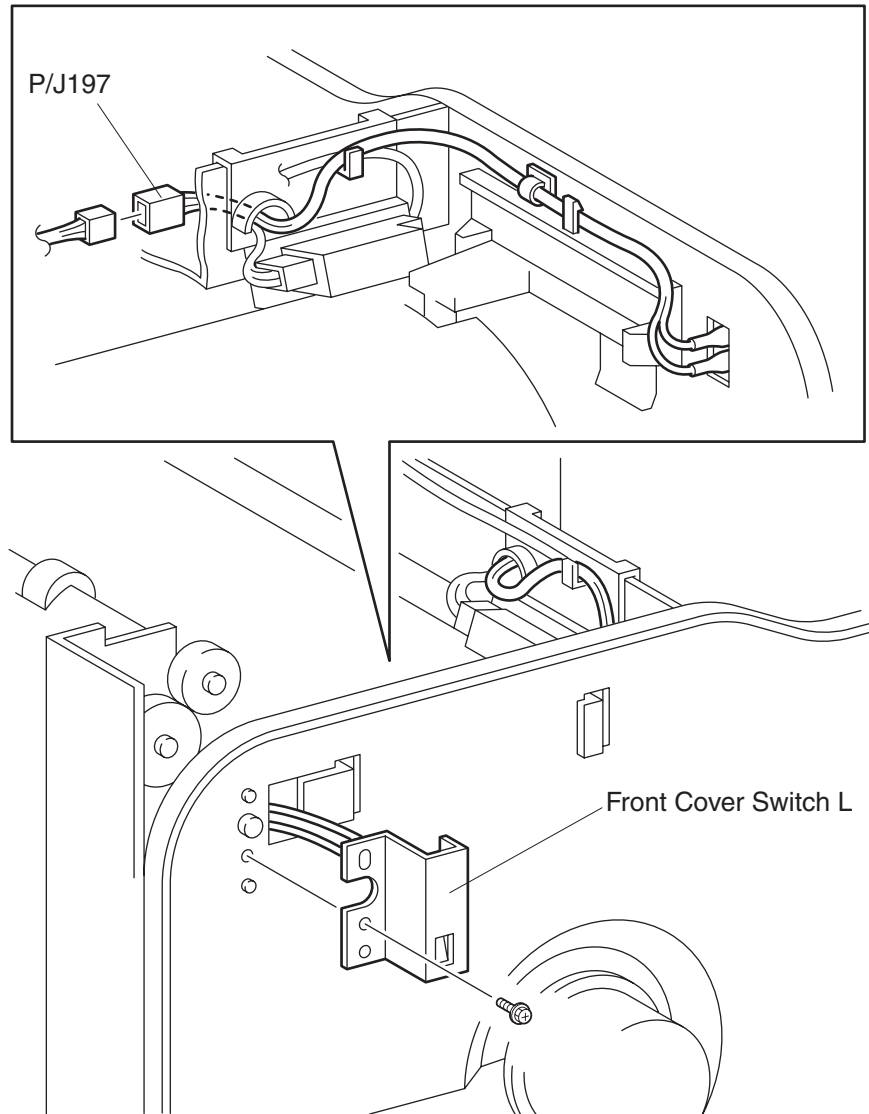

RS2019XB

RS2019XB

## **RRP 9.125 Front Cover Switch L (PL13.2.4)**

---

### **Removal**

1. Remove the Inner Cover (RRP 9.2).
2. Remove the Top Cover (RRP 9.3).
3. Disconnect P/J197 from the Front Cover Switch L.
4. Free the Switch wire harness from the wire clips.
5. Remove the screw securing the Front Cover Switch L to the printer frame and remove the Switch.

### **Replacement**

1. Reinstall the Front Cover Switch L into the cutout in the printer frame.
2. Secure the Switch wire harness under the wire clips.
3. Reconnect P/J197 to the Front Cover Switch L.
4. Reinstall the Top Cover (RRP 9.3).
5. Reinstall the Inner Cover (RRP 9.2).

## RRP 9.126 Environment Sensor (PL13.2.5)

---

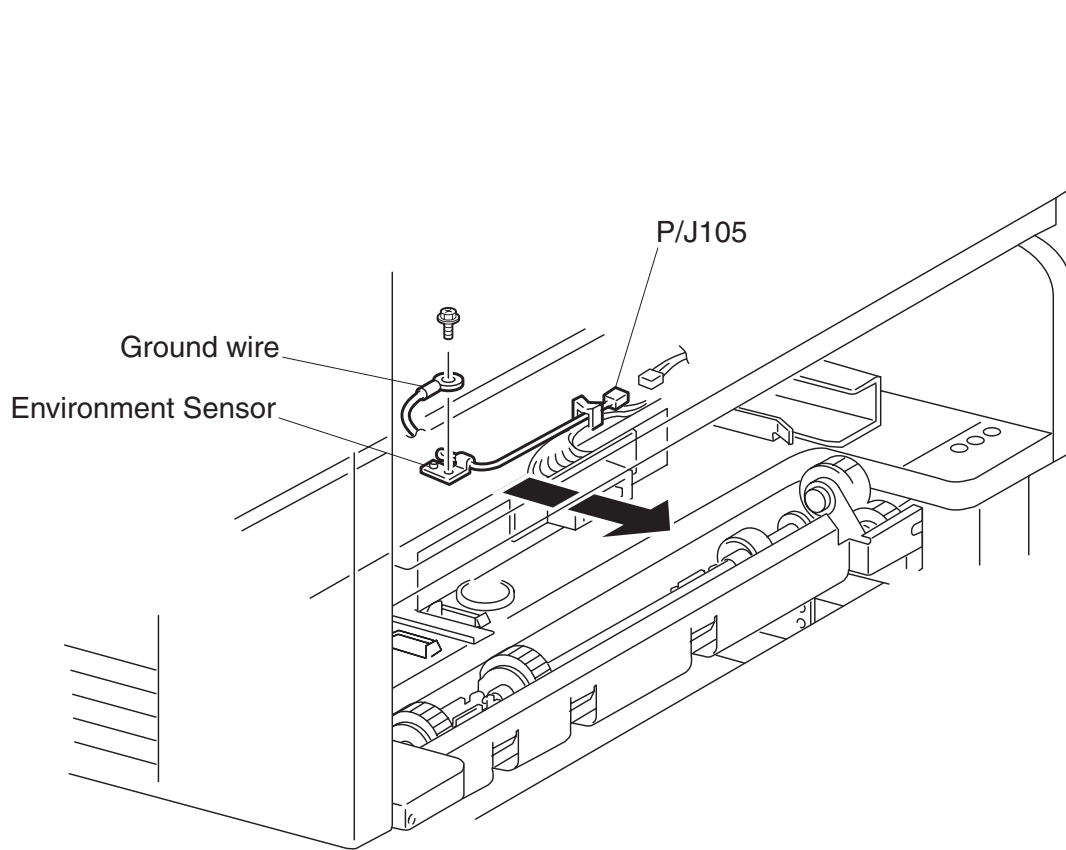

RS2020XB

RS2020XB



## **RRP 9.126 Environment Sensor (PL13.2.5)**

---

### **Removal**

1. Remove the Xerographic Cartridge (RRP 9.48).
2. Slide the Main Paper Handling Assembly out of the printer.
3. Disconnect P/J 105 from the Environment Sensor.
4. Remove the screw securing the Ground Wire and the Environment Sensor to the printer frame, push the Wire aside and remove the Sensor.

### **Replacement**

1. Reinstall the Environment Sensor onto the printer frame.
2. Align the Sensor so the positioning hole and the screw hole in the Sensor line up with the positioning tab and screw hole in the printer frame.
3. Reinstall the Ground Wire over the screw hole in the Sensor.
4. Use one screw to secure the Sensor and Ground Wire to the frame.
5. Reconnect P/J 105 to the Environment Sensor.
6. Slide the Main Paper Handling Assembly into the printer.
7. Reinstall the Xerographic Cartridge (RRP 9.48).

## RRP 9.127 Controller Chassis Assembly (PL14.1.1)

---

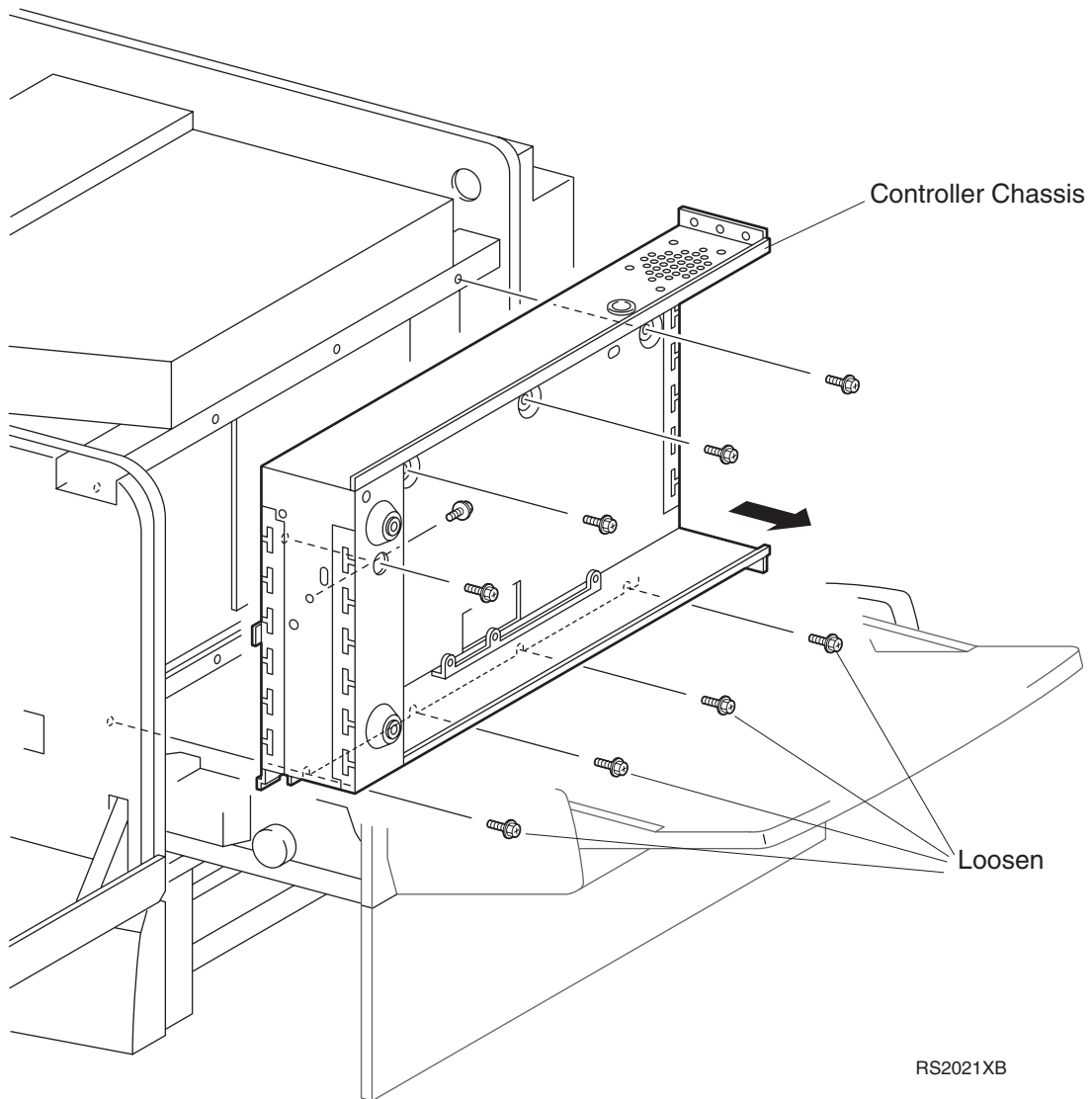

RS2021XB

## **RRP 9.127 Controller Chassis Assembly (PL14.1.1)**

---

### **Removal**

1. Remove the Controller Fan (RRP 9.128).
2. Remove the Controller PWB (RRP 9.129).
3. Slide the Main Paper Handling Assembly several inches out of the printer engine.
4. Loosen, but do not remove, the four screws securing the bottom of the Controller Chassis Assembly to the printer frame.
5. Remove the four screws securing the top of the Controller Chassis Assembly to the printer frame.
6. Lift the Controller Chassis Assembly up and off of the four loosened screws at located at the bottom of the Chassis, and remove the Chassis Assembly from the printer frame.

### **Replacement**

1. Slide the Main Paper Handling Assembly several inches out of the printer engine.
2. Lower Controller Chassis Assembly onto the printer frame so the four notches located at the bottom of the Controller Chassis Assembly slide behind the four loosened screws on the printer frame.
3. Use four screws to secure the top of the Controller Chassis Assembly to the printer frame.
4. Tighten the four screws at the bottom of the Controller Chassis Assembly.
5. Reinstall the Controller PWB (RRP 9.129).
6. Reinstall the Controller Fan (RRP 9.128).

## RRP 9.128 Controller Fan (PL14.1.2)

---

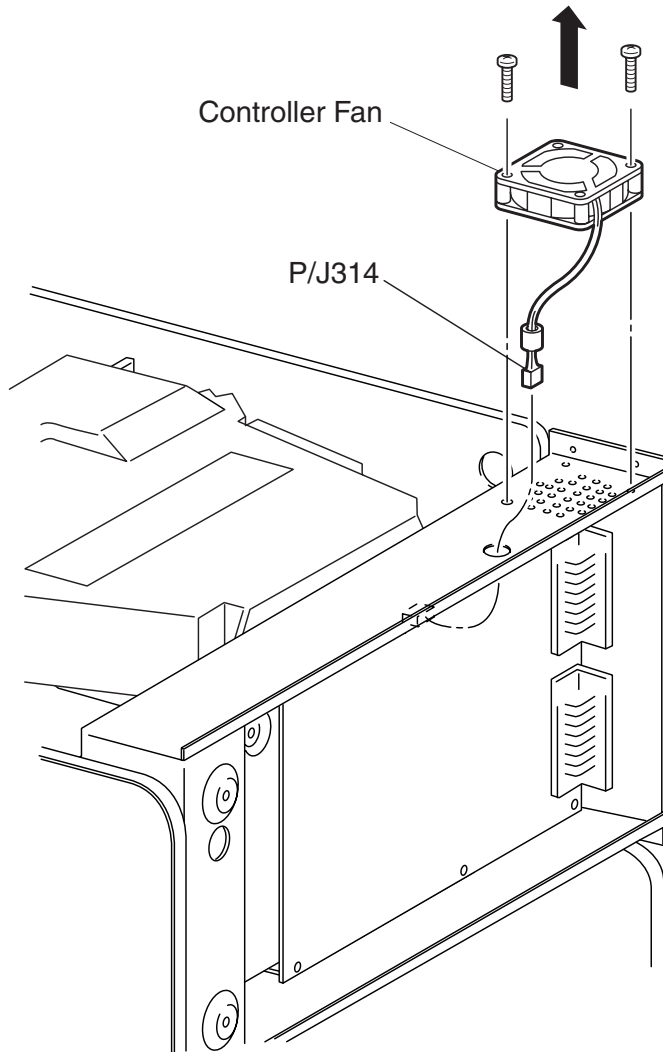

RS2022XB

RS2022XB

## **RRP 9.128 Controller Fan (PL14.1.2)**

---

### **Removal**

1. Remove the Right Cover (RRP 9.8).
2. Remove the Top Cover (RRP 9.3).
3. Disconnect the Controller Fan P/J 314 from the Controller PWB.
4. Remove the two screws securing the Controller Fan to the printer frame and remove the Fan.

### **Replacement**

1. Position the Controller Fan with the label facing up and the wires close to the grommet hole.
1. Reinstall the Fan onto the printer frame.
2. Use two screws to secure the Fan to the printer frame.
3. Route the Fan wire through the grommet hole.
4. Reconnect the Controller Fan P/J 314 to the Controller PWB.
5. Reinstall the Top Cover (RRP 9.3).
6. Reinstall the Right Cover (RRP 9.8).

## RRP 9.129 Controller PWB (PL14.1.10)

---

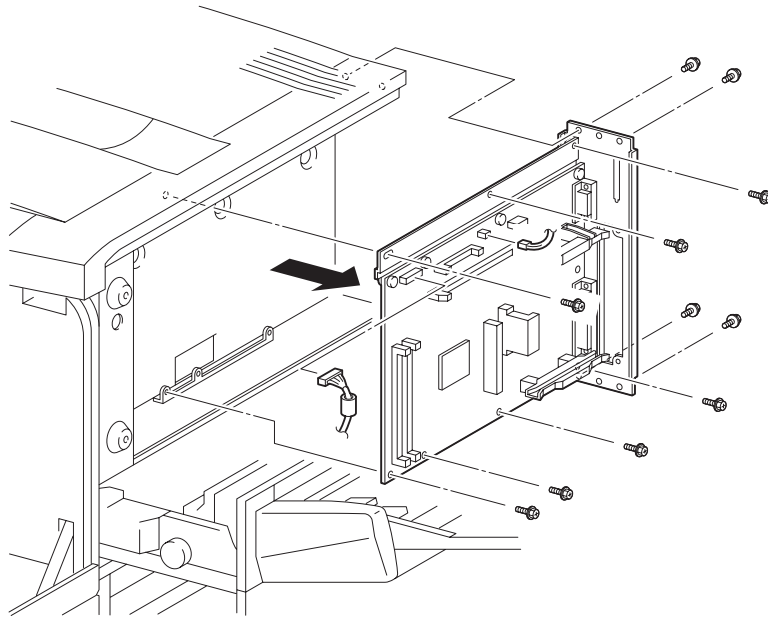

Figure 1

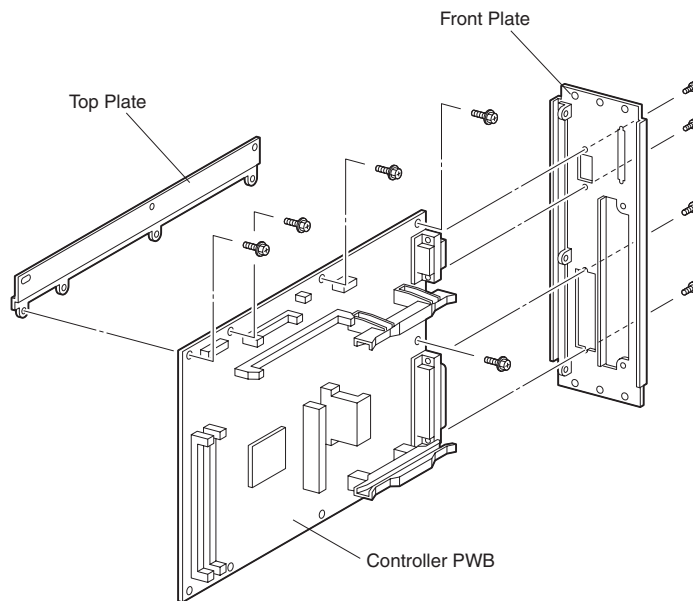

Figure 2

RS2023XB

RS2023XB

## RRP 9.129 Controller PWB (PL14.1.10)

---

### Removal

1. Disconnect all interface cables running to the Controller PWB.
2. Remove the Right Cover Assembly (RRP 9.8).
3. Disconnect all P/J's from the Controller PWB.
4. Remove the eleven screws securing the Controller PWB to the Controller Chassis and pull the Controller away from the Chassis, disconnecting the Controller from the MCU PWB (Figure 1).
5. Remove the four screws securing the Top Plate to the Controller PWB and remove the Plate.
6. Remove the four screws securing the End Plate to the Controller PWB and remove the End Plate.



*Wear an electrostatic wrist strap and use caution when working with the Controller PWB. Static electricity can damage the sensitive electronics of the Controller PWB.*

*Handle the Controller PWB by the edges of the board. Never touch any of the ICs that are mounted on the PWB.*

### Replacement

1. Reinstall the End Plate onto the Controller PWB and use four screws to secure the End Plate.
2. Reinstall the Top Plate onto the Controller PWB and use four screws to secure the Top Plate.
3. Position the Controller PWB so the P/J on the back of the Controller lines up with P/J 11 on the MCU PWB.
4. Press the Controller PWB against the Controller Chassis so the P/J on the back of the Controller connects with P/J 11 on the MCU PWB.
5. Use eleven screws to secure the Controller PWB to the Controller Chassis.
6. Reconnect all P/J's to the Controller PWB.
7. Reinstall the Right Cover Assembly (RRP 9.8).
8. Reconnect all interface cables to the Controller PWB.

## RRP 9.130 Fuser Entrance Sensor (PL9.4.4)

---

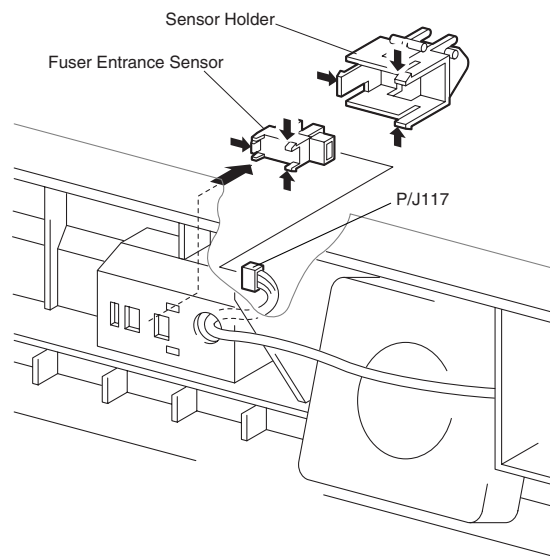
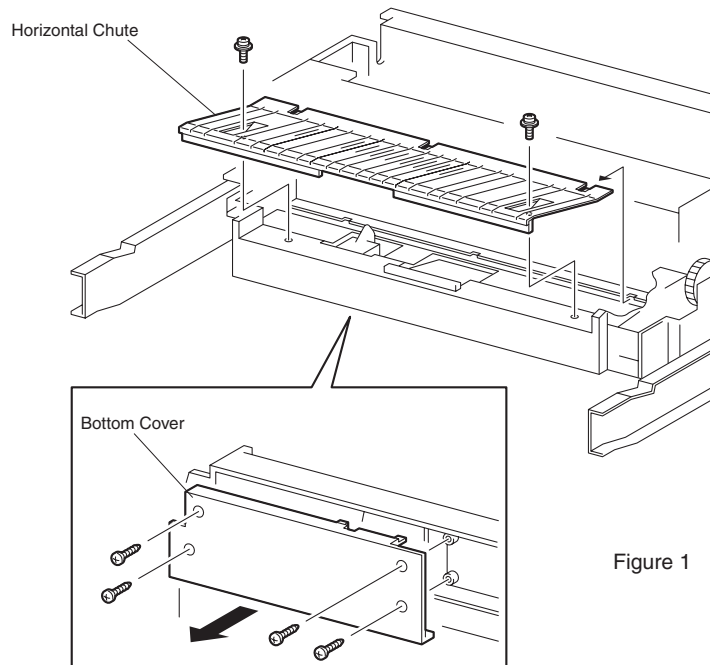

RS2025XA

RS2025XA



## **RRP 9.130 Fuser Entrance Sensor (PL9.4.4)**

---

### **Removal**

1. Remove the Fuser Assembly (RRP 9.80).
2. Remove the two screws securing the Horizontal Chute to the Fuser Tray and remove the Chute (Figure 1).
3. Remove the four screws securing the Bottom Cover to the Fuser Tray and remove the Cover.
4. Release the latches securing the Fuser Entrance Sensor Holder to the Fuser Tray and remove the Holder (Figure 2).
5. Disconnect the P/J 117 from the Entrance Sensor.
6. Release the latches securing the Fuser Entrance Sensor to the Fuser Tray and remove the Sensor.

### **Replacement**

1. Reinstall the Fuser Entrance Sensor by pressing the latches on the bottom of the Sensor into the holes in the Fuser Tray.  
The Sensor snaps into place.
2. Reconnect P/J 117 to the Fuser Entrance Sensor.
3. Reinstall the Fuser Entrance Sensor Holder by placing the Holder over the reinstalled Sensor, then pressing the latches on the bottom of the Holder into the holes in the Fuser Tray.  
The Holder snaps into place.
4. Reinstall the Bottom Cover onto the Fuser Tray and use four screws to secure the Cover.
5. Reinstall the Horizontal Chute onto the Fuser Tray and use two screws to secure the Chute.
6. Reinstall the Fuser Assembly (RRP 9.80).

## RRP 9.131 Fuser Chute Fan (PL9.4.10)

---

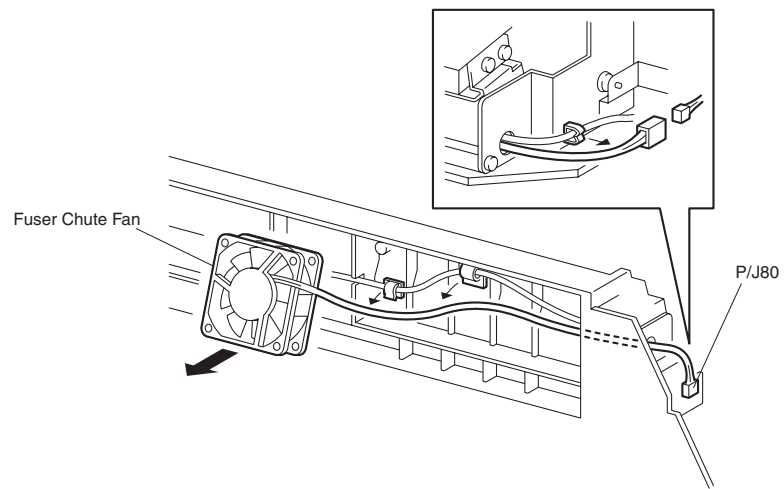
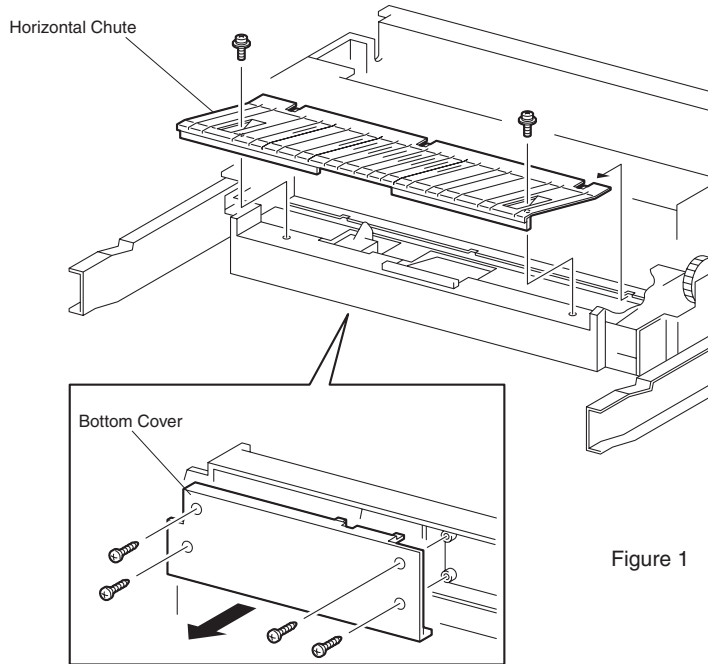

RS2026XA

RS2026XA

## **RRP 9.131 Fuser Chute Fan (PL9.4.10)**

---

### **Removal**

1. Remove the Fuser Assembly (RRP 9.80).
2. Remove the two screws securing the Horizontal Chute to the Fuser Tray and remove the Chute (Figure 1).
3. Remove the four screws securing the Bottom Cover to the Fuser Tray and remove the Cover.
4. Remove the Fuser Chute Fan from the Fuser Tray (Figure 2).
5. Disconnect the P/J 80 from the Fan.

### **Replacement**

1. Reinstall the Fuser Chute Fan into the slot in the Fuser Tray.
2. Route the Fan wire harness through the slots in the Fuser Tray and out through the hole in the rear of the Tray.
3. Reconnect P/J 80 to the Fan.
4. Reinstall the Bottom Cover onto the Fuser Tray and use four screws to secure the Cover.
5. Reinstall the Horizontal Chute onto the Fuser Tray and use two screws to secure the Chute.
6. Reinstall the Fuser Assembly (RRP 9.80).

Blank Page

**Section 10 - Locating P/J Connectors****Contents**

---

P/J Location Table .....	10-2
P/J Location Map 1 .....	10-9
P/J Location Map 2 .....	10-10
P/J Location Map 3 .....	10-11
P/J Location Map 4 .....	10-12
P/J Location Map 5 .....	10-13
P/J Location Map 6 .....	10-14
P/J Location Map 7 .....	10-15
P/J Location Map 8 .....	10-16

**Use the table and maps in this section to locate specific P/J connectors within the printer.**

To find the location of a P/J:

1. Locate the P/J connector number in the first column of the table.
2. Locate the corresponding map and location number, such as M2-E201, in the second column.
3. Go to the map (M2) number and locate coordinates (E201).

**P/J Location Table**

<b>P/J</b>	<b>Map &amp; Coordinates</b>	<b>Connected to...</b>	<b>Other end connected to...</b>
10	M2-D205	MCU PWB	--
11	M2-E205	MCU PWB	Controller PWB
12	M2-D205	MCU PWB	LVPS P/J33
13	M2-D205	MCU PWB	Laser Diode PWB P/J122
14	M2-D204	MCU PWB	ROS Assembly P/J121, P/J123, P/J124
16	M2-D204	MCU PWB	Xerographic Cartridge & HVPS
17	M2-E204	MCU PWB	ADC Sensor P/J81 Erase Lamp P/J86
18	M2-E203	MCU PWB	Waste Toner Sensor P/J88 Toner Box Sensor P/J83
19	M2-F203	MCU PWB	Fuser Assembly P/J71
20	M2-F204	MCU PWB	Main Paper Handling Assembly P/J91
32	M6-D609	LVPS	MCU PWB P/J21
33	M6-D610	LVPS	MCU PWB P/J12
35	M6-G609	LVPS	Main Fuser Assembly P/J71
41	M6-C609	HVPS	LVPS P/J32
42	M6-C609	HVPS	MCU PWB P/J16
49 CN1	M6-E609	Paper Handling Motor	LVPS P/J32
50 CN2	M6-608	Paper Handling Motor	MCU PWB P/J17
CN3	M6-E609	Mounted on Paper Handling Motor PWB	--

**P/J Location Table continued**

<b>P/J</b>	<b>Map &amp; Coordinates</b>	<b>Connected to...</b>	<b>Other end connected to...</b>
CN4	M6-E608	Mounted on Paper Handling Motor PWB	--
51	M6-D608	Process Motor	LVPS P/J32
52	M6-D607	Process Motor	MCU PWB P/J17
55	M7-E708	Dispense Motor	MCU PWB P/J18
56	M7-F708	Developer Clutch	MCU PWB P/J19
56A	M7-F708	P/J56	MCU PWB P/J19
57	M5-C509	TR0 Sensor	MCU PWB P/J17
58	M7-F708	Rotary Sensor	MCU PWB P/J19
62	M8-E812	Cleaner Cam Solenoid	Fuser Tray Assembly P/J71
62A	M8-E812	Cleaner Cam Solenoid P/J62	Fuser Tray Assembly P/J71
63	M7-C710	BTR Cam Solenoid	MCU PWB P/J19
63A	M7-C710	P/J63	MCU PWB P/J19
68	M6-B610	--	Optional High Capacity Feeder
68A	M6-B610	P/J68	Optional High Capacity Feeder
69A	M8-H813	Optional High Capacity Feeder	--
69B	M8-H813	--	Optional High Capacity Feeder
70	M7-F711	Fuser Assembly P/J71	LVPS P/J32
71	M7-F710	Fuser Assembly	P/J70
71A	M7-F710	Fuser Tray Assembly P/J71	MCU PWB P/J18
72A	M8-G812	P/J72B	Main Fuser Assembly P/J71
72B	M8-G812	P/J72A	Temperature Sensor Assembly
73	M8-I812	Oil Cam Solenoid	P/J73A
73A	M8-I812	P/J73 Oil Cam Solenoid	Fuser Tray Assembly P/J71
74	M8-I813	Exchange Solenoid	P/J74A

**P/J Location Table continued**

<b>P/J</b>	<b>Map &amp; Coordinates</b>	<b>Connected to...</b>	<b>Other end connected to...</b>
74A	M8-I813	P/J74	Fuser Tray Assembly P/J71
75	M8-H807	Fuser Exit Sensor	Main Fuser Assembly P/J72B
76	M8-F813	P/J117 Fuser IN Sensor	Main Fuser Assembly P/J76A
76A	M8-F813	P/J76	Fuser Tray Assembly P/J71
77	M8-G808	CRU Switch Assembly	Main Fuser Assembly P/J77A
77A	M8-G808	P/J77	Main Fuser Assembly P/J71
78A	M8-I813	P/J78B	Main Fuser Assembly P/J71
78B	M8-I813	P/J78A	Loop
79	M8-F812	Pressure Roll Heat Rod Thermal Fuse	Main Fuser Assembly P/J71
80	M8-D813	Fuser Chute Fan	Fuser Tray Assembly P/J80A
80A	M8-D813	P/J80	Fuser Tray Assembly P/J71
81	M1-C110	ADC Sensor Assembly	P/J81A
81A	M1-C110	P/J81	MCU PWB P/J17
82	M6-G608	Developer Fan	P/J82A
82A	M6-G608	P/J82A	MCU PWB P/J17
83	M1-G106	Toner Box Sensor	P/J83A
83A	M1-G106	P/J83	P/J116
84	M1-I107	CRUM Assembly P/J85	P/J84A
84A	M1-I107	P/J84A	MCU PWB P/J16
85	M1-H107	CRUM Assembly	P/J84
86	M1-I105	Erase Lamp	P/J86A
86A	M1-I105	P/J86A	MCU PWB P/J17
87	M5-I506	Used Cartridge Sensor	MCU PWB P/J17
88	M1-F106	Waste Toner Sensor	P/J116
89	M8-D805	Cartridge Sensor P/J168	P/J89A
89A	M8-D805	P/J89	P/J161B



**P/J Location Table continued**

<b>P/J</b>	<b>Map &amp; Coordinates</b>	<b>Connected to...</b>	<b>Other end connected to...</b>
90A	M4-G409	P/J90B	Main Paper Handling Assembly P/J91
90B	M4-G409	P/J90A	Loop
91	M2-D211 M4-E408	Main Paper Handling Assembly	MCU PWB P/J20
92A	M4-E409	MSI Assembly P/J92B	Main Paper Handling Assembly P/J91
92B	M4-E409	MSI Assembly	Main Paper Handling Assembly P/J92A
93	M4-D408	Registration Sensor	Main Paper Handling Assembly P/J91
94	M4-F408	Registration Clutch	P/J94A
94A	M4-F408	P/J94	Main Paper Handling Assembly P/J110B & P/J115
95	M4-G408	Pre-Registration Clutch	P/J95A
95A	M4-G408	P/J95	Main Paper Handling Assembly P/J110B & P/J115
97	M2-F204	Main Paper Handling Assembly P/J 91	Front Cover Switch R P/J191 & P/J70
101	M2-D212	Tray No Paper Sensor P/J107	P/J101A
101A	M2-D212	P/J101	MCU PWB P/J20
102	M7-D711	Size Switch Assembly	MCU PWB P/J19
103A	M2-F206	P/J103B	MCU PWB P/J19
103B	M2-F206	Feed Solenoid	P/J103A
104	M2-D212	P/J104A	Terminated
104A	M2-D212	P/J104	MCU PWB P/J20
105	M2-D205	Environment Sensor	P/J105A
105A	M2-D205	P/J105	MCU PWB P/J20
106	M2-E211	Low Paper Sensor	P/J106A
106A	M2-E211	P/J106	MCU PWB P/J20
107	M2-E213	Tray No Paper Sensor	P/J 101
109	M4-D409	Registration Brake Clutch	P/J109A

**P/J Location Table continued**

<b>P/J</b>	<b>Map &amp; Coordinates</b>	<b>Connected to...</b>	<b>Other end connected to...</b>
109A	M4-D409	P/J109	Main Paper Handling Assembly P/J91
110A	M4-G408	P/J110B	Main Paper Handling Assembly P/J91
110B	M4-G408	P/J94A, P/J95A, & P/J115	P/J110A
111A	M7-G70 M8-D805	P/J111B	MCU PWB P/J17
111B	M8-D806	P/J111A	Fuser Fan
113A	M4-E409	MSI Assembly P/J113B	Main Paper Handling Assembly P/J91
113B	M4-E409	P/J113A	MSI Short No Paper Sensor P/J203 MSI Clutch P/J202A-P/J202B Pick Up Solenoid P/J201A-P/J202B
115	M4-H408	P/J94A & P/J95A	Terminated
116	M1-H106	P/J83A Waste Toner Sensor P/J88	P/J116A
116A	M1-H106	P/J116	MCU PWB P/J18
117	M5-D507	Fuser IN Sensor	P/J76
121	M5-D507	Laser Diode Assembly	MCU PWB P/J14 P/J196
122	M5-D506	Laser Diode Assembly	MCU PWB P/J13
123	M5-E506	Scanner Assembly	MCU PWB P/J14
124	M5-C506	Start of Scan Sensor	MCU PWB P/J14
131	M6-B610	P/J131A	Feeder PWB P/J133
131A	M6-B610	P/J131	MCU PWB P/J16
132	M6-B610	P/J132A	Feeder PWB P/J133
132A	M6-B610	P/J132	LVPS P/J33
161A	M7-G707 M8-D805	P/J161B	MCU PWB P/J17
161B	M8-D805	P/J161A	Top Exit Sensor P/J165 Exit Chute Switch P/J166
163A	M7-G707 M8-D805	P/J163B	MCU PWB P/J17

**P/J Location Table continued**

<b>P/J</b>	<b>Map &amp; Coordinates</b>	<b>Connected to...</b>	<b>Other end connected to...</b>
163B	M8-D805	P/J163A	Full Stack Sensor P/J167
165	M8-F804	Top Exit Sensor	P/J161B
166	M8-E804	Exit Chute Switch	P/J161B
167	Not on map	Full Stack Sensor	P/J163B
168	M8-J802	Cartridge Sensor	P/J89
191	M1-E109	Front Cover Switch R	P/J97
192	M1-E109	Front Cover Switch R	P/J33
193	M1-E109	Front Cover Switch R	P/J33
194	M1-E109	Front Cover Switch R	P/J195
195	M6-H607	Top Cover Switch	P/J195A
195A	M6-H607	P/J195	P/J194 P/J196
196	M2-F203	Laser Diode Assembly P/J121	P/J195 LVPS P/J33
197	M5-H506	Front Cover Switch L	P/J197A
197A	M5-H506	P/J197	MCU PWB P/J19
201A	M4-I408	P/J201B	MSI Assembly P/J113B
201B	M4-I408	Pick Up Solenoid	P/J201A
202A	M4-H408	P/J202B	MSI Assembly P/J113B
202B	M4-H408	MSI Pick Up Solenoid	P/J201A
203	M4-G409	MSI Short No Paper Sensor	MSI Assembly P/J 113B
204	M4-G408	MSI Edge Sensor	MSI Assembly P/J92B P/J207
206	M4-G409	MSI Long No Paper Sensor	MSI Assembly P/J92B P/J207
207	M4-F409	MSI Assembly P/J92B	P/J204 P/J205 P/J206

**P/J Location Table continued**

<b>P/J</b>	<b>Map &amp; Coordinates</b>	<b>Connected to...</b>	<b>Other end connected to...</b>
245	M6-F608	Rotary Motor PWB	MCU PWB P/J16
246	M6-F607	Rotary Motor PWB	LVPS P/J32
247	M6-E607	Rotary Motor PWB	Rotary Motor
F421	M5-D508	BCR Connector	HVPS P/J-A
F422	M1-B108	Developer Contact Assembly	HVPS P/J-C
F423	M5-D511	DTS Plate	HVPS P/J-G
F791	M8-F807	Pressure Roll Heat Rod	Heat Roll Heat Rod
A	M6-B606	HVPS	P/J F421
C	M6-C607	HVPS	P/J F422
D	M6-B609	HVPS	1ST BTR Bias Plate
F	M6-B608	HVPS	2ND BTR Contact Plate
G	M6-B608	HVPS	P/J F423
T1	M8-G811	Heat Roll Heat Rod	P/J79
T2	M8-I806	Pressure Roll Heat Rod	P/J79
T3	M5-D510	1ST BTR Bias Plate	HVPS P/J-D
T4	M5-E510	2ND BTR Contact Plate	HVPS P/J-F
T5	M8-I806	Heat Roll Heat Rod	T1
310	M3-F306	Controller PWB	Operation Panel P/J317
314	M3-G306	Controller PWB	Controller Fan
317	M3-C306	Operation Panel	Controller PWB P/J314

**P/J Location Map 1**

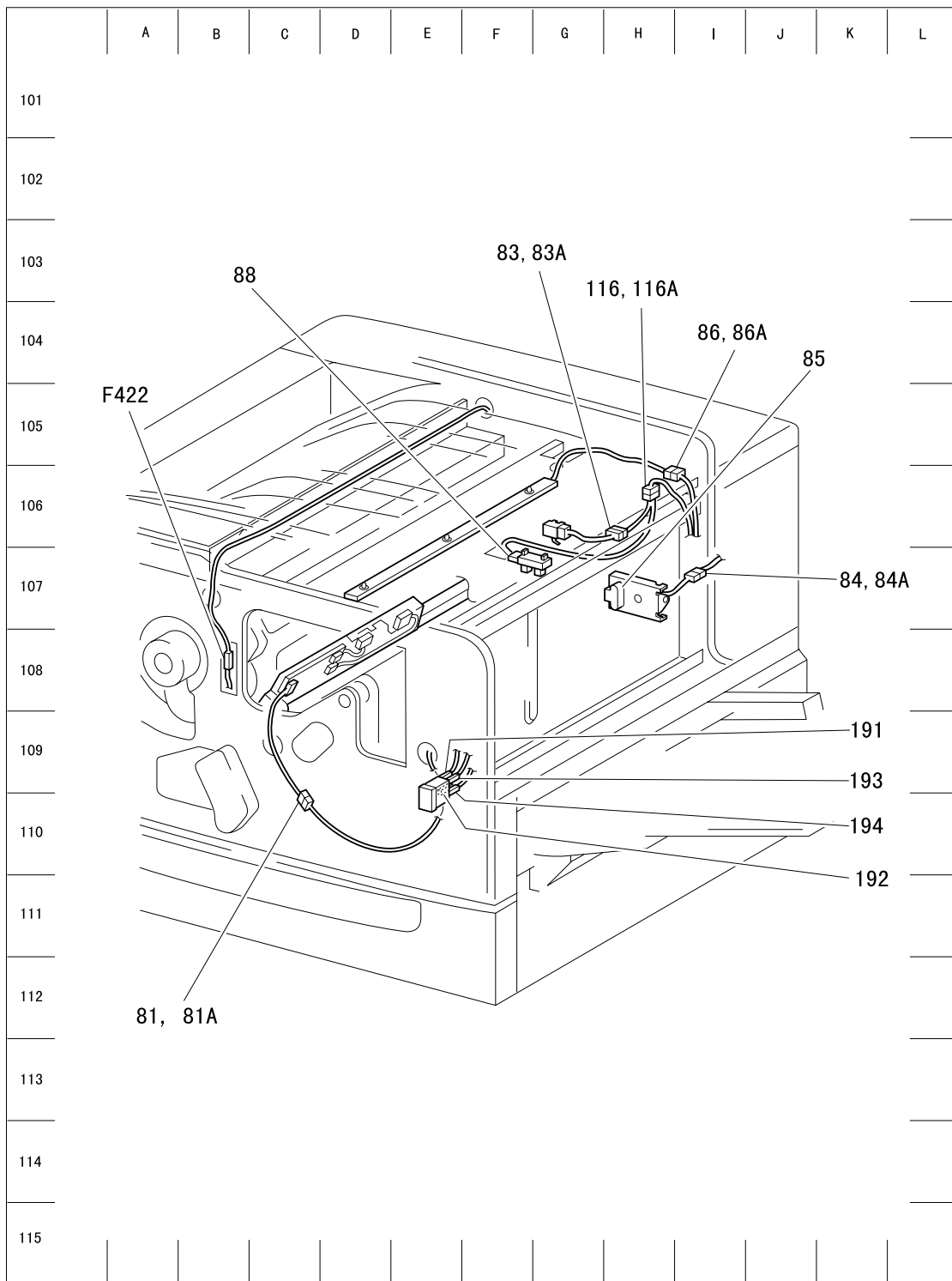

RS1101XB

RS1101XB

### P/J Location Map 2

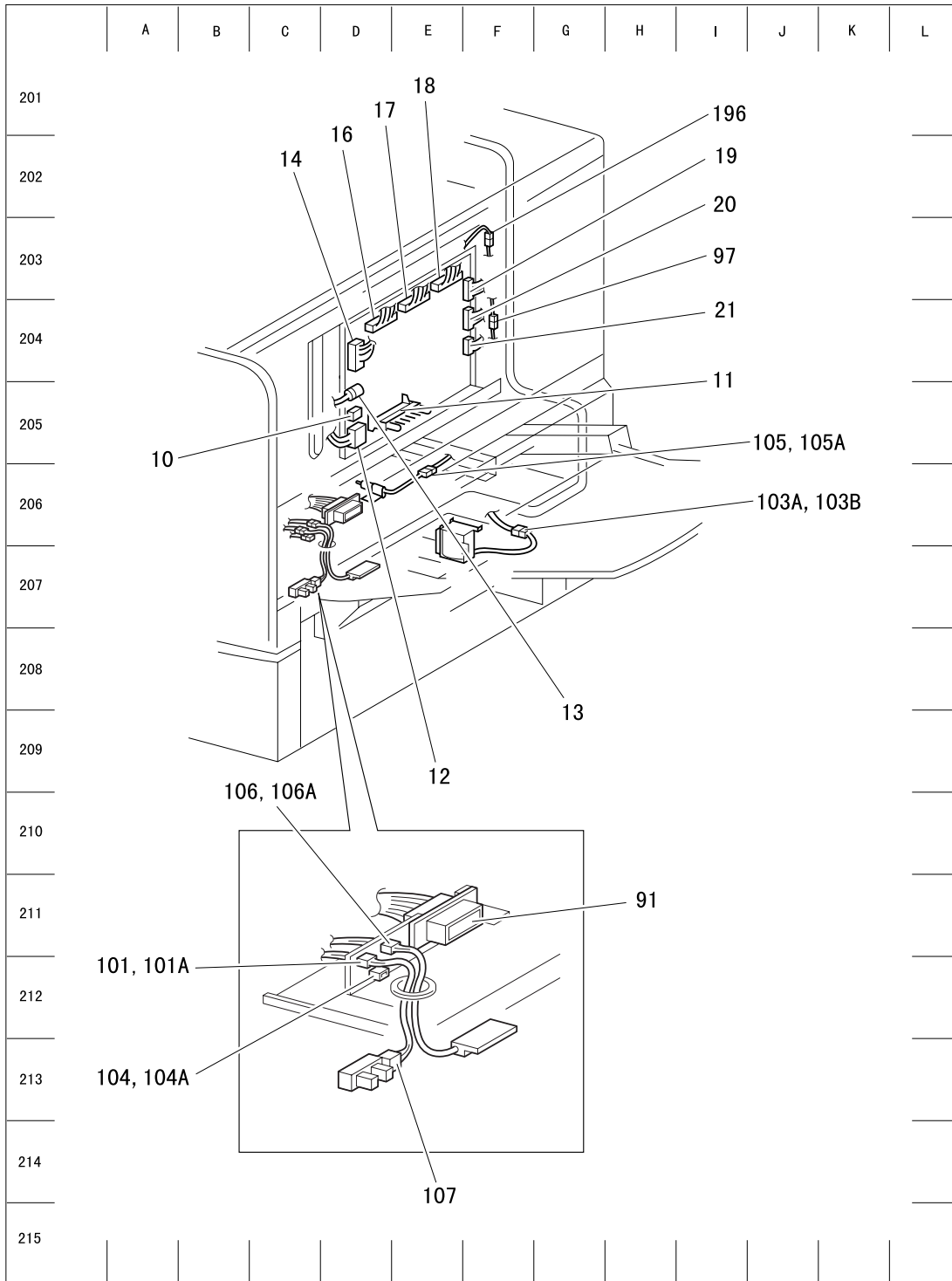

RS1102XC

RS1102XC

**P/J Location Map 3**

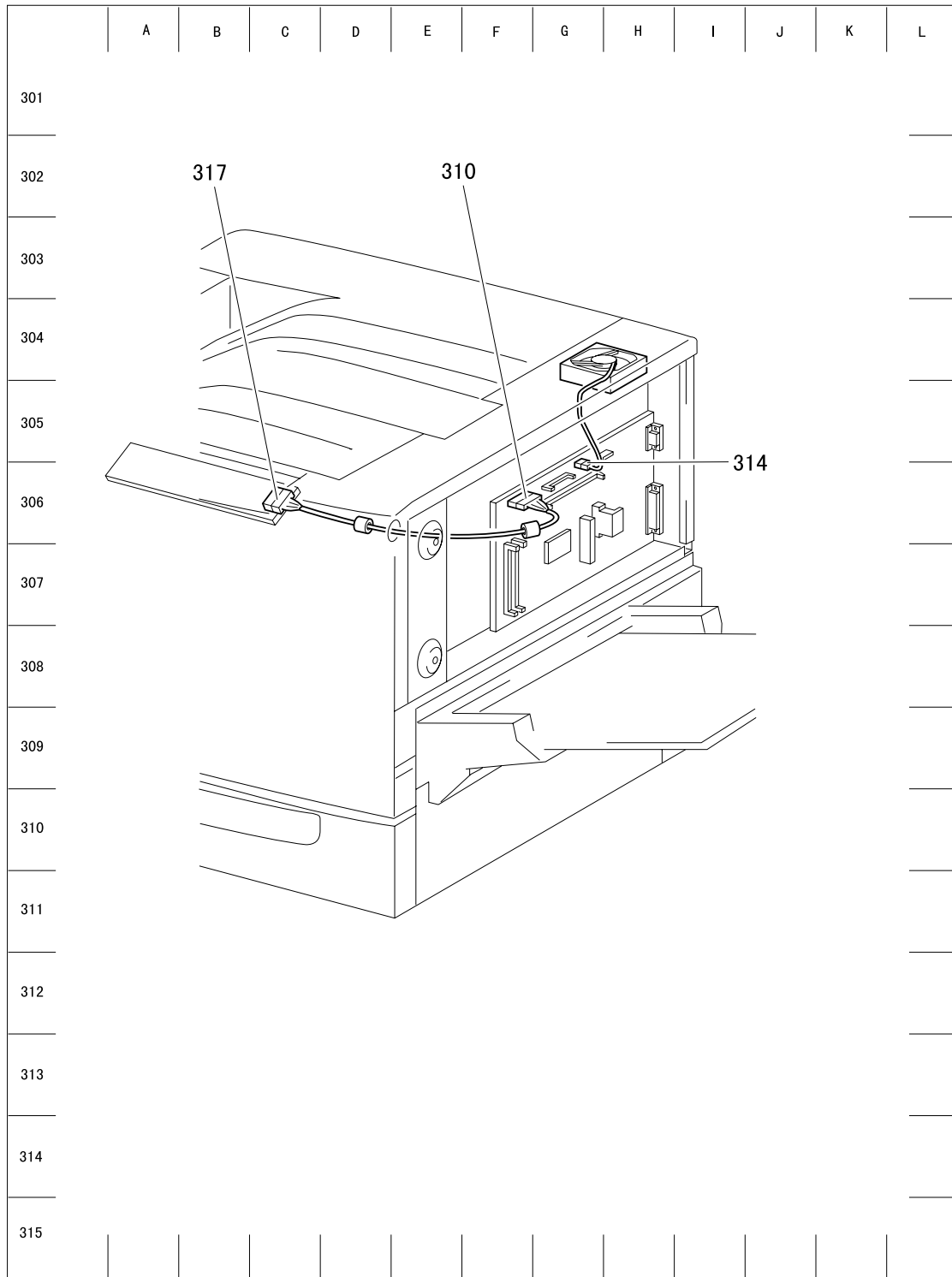

RS1103XB

RS1103XB

### P/J Location Map 4

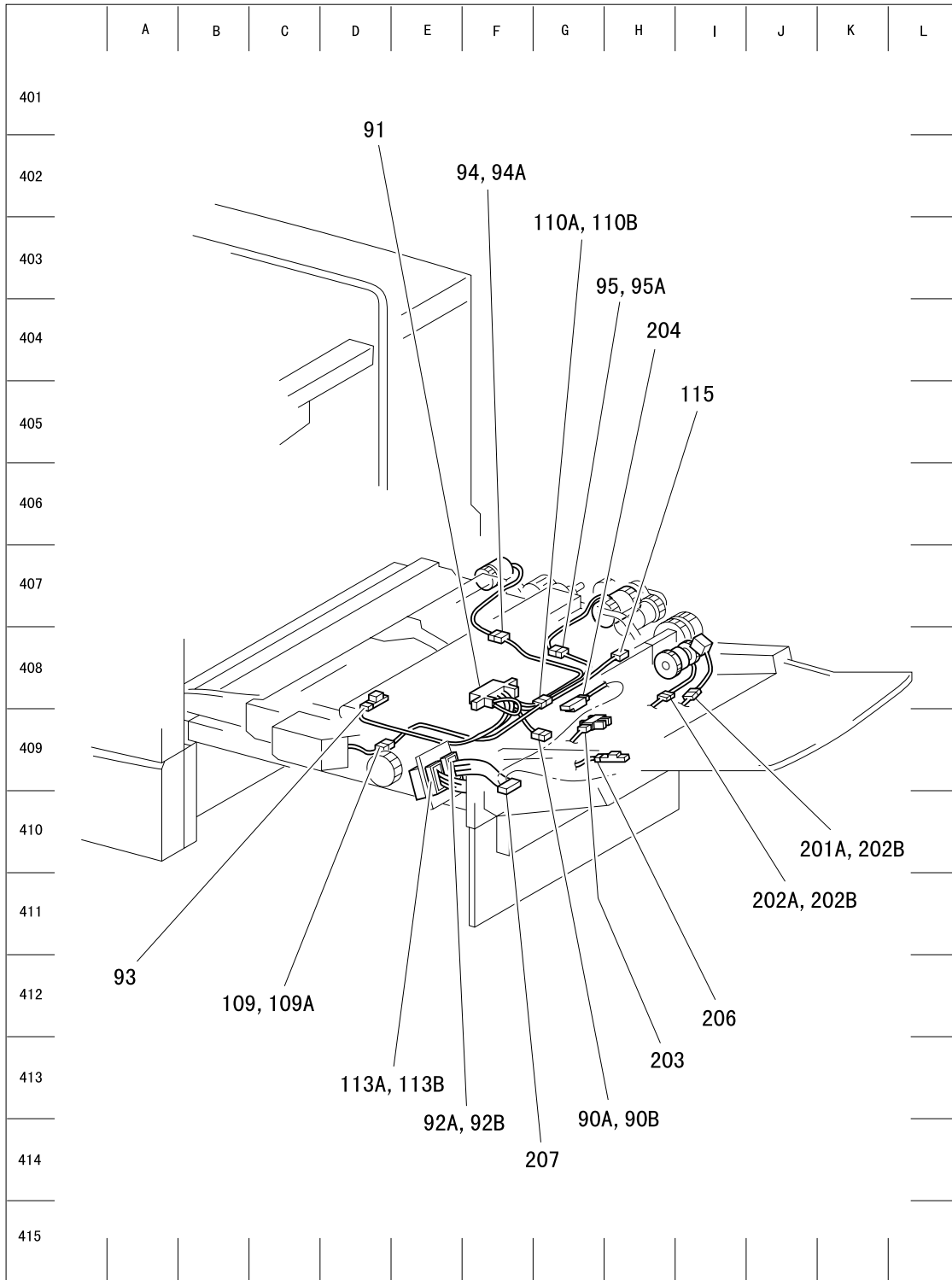

RS1104XC

RS1104XC



**P/J Location Map 5**

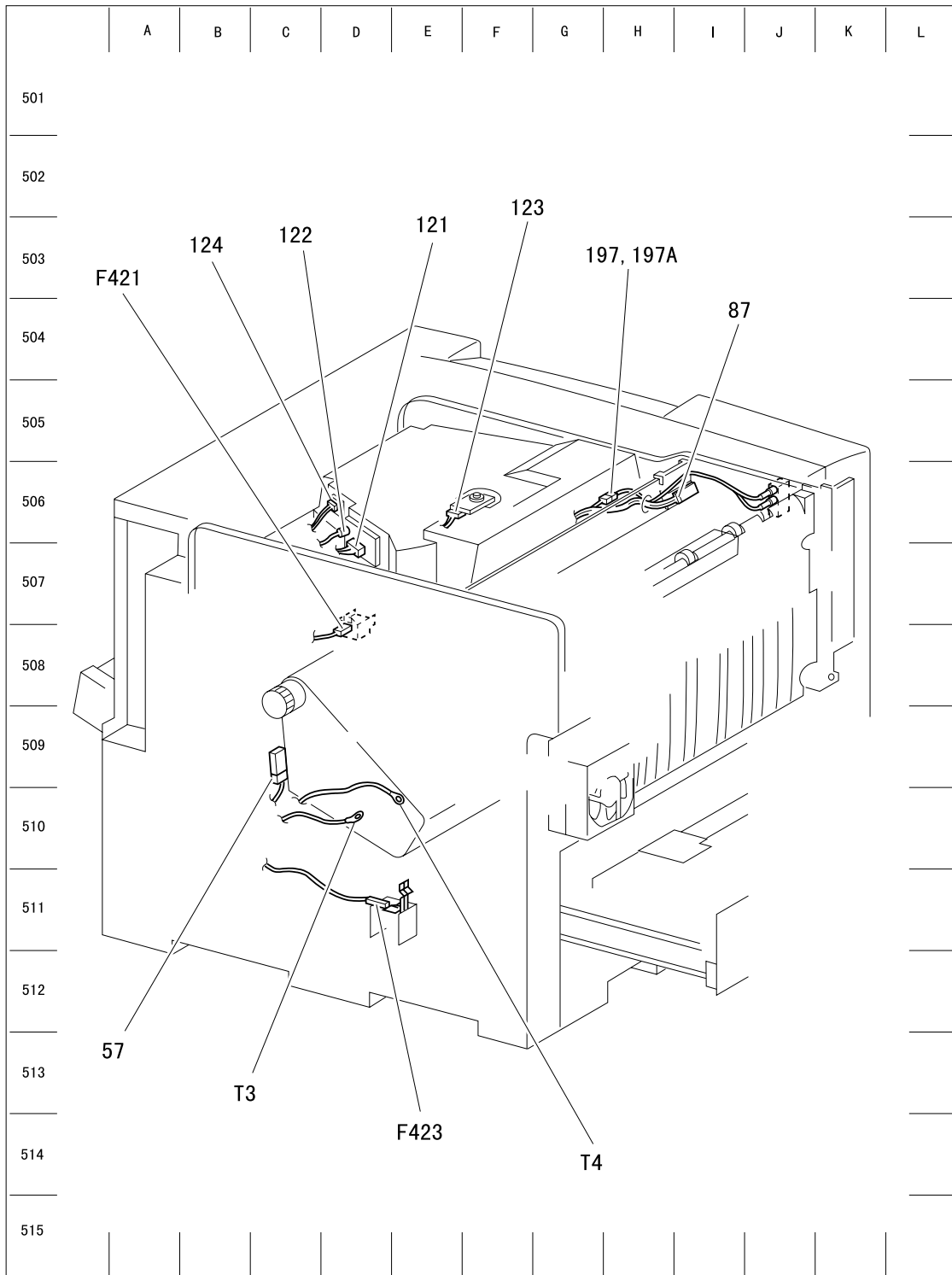

RS1105XB

RS1105XB

**P/J Location Map 6**

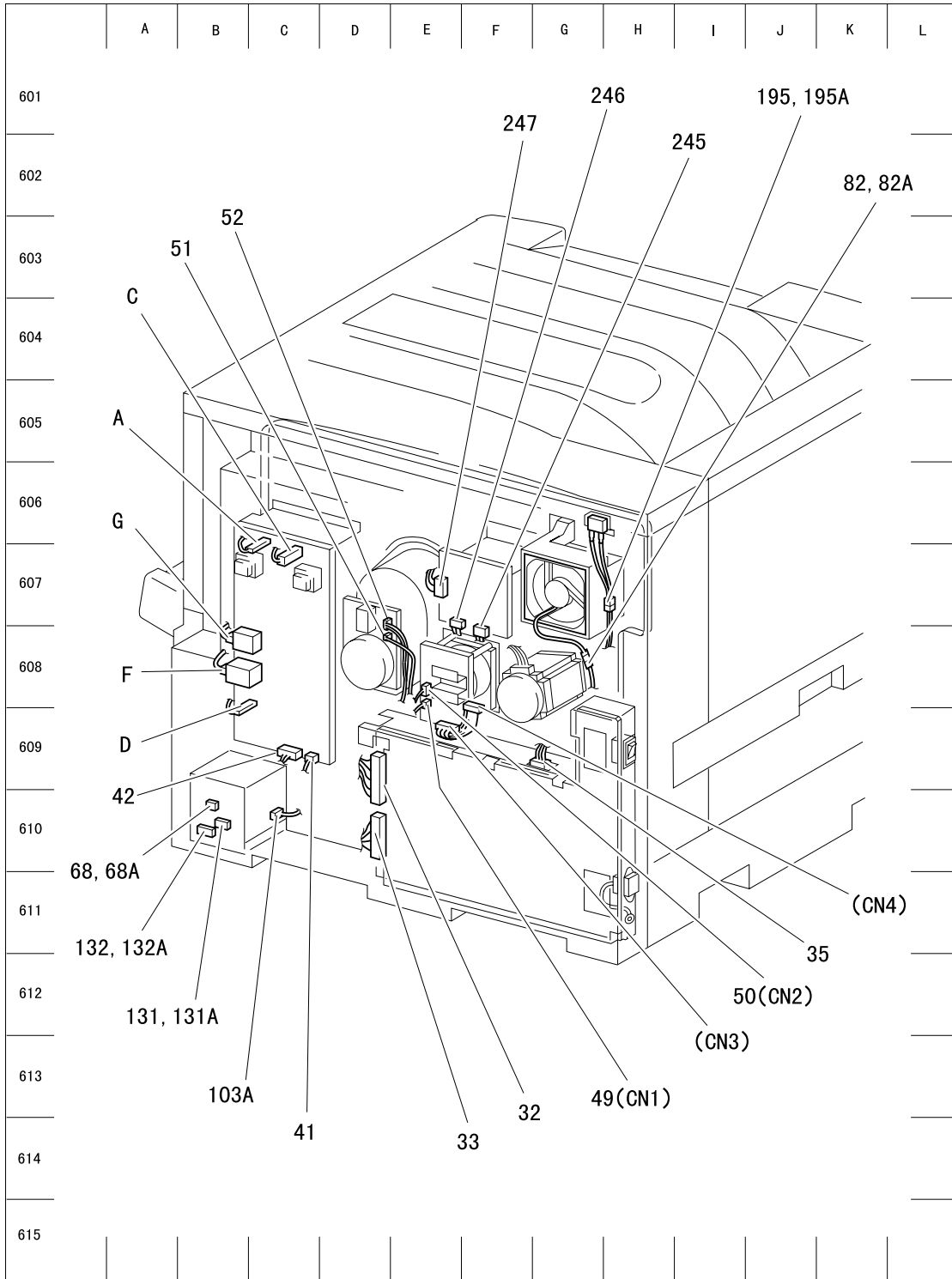

RS1106XB

RS1106XB

**P/J Location Map 7**

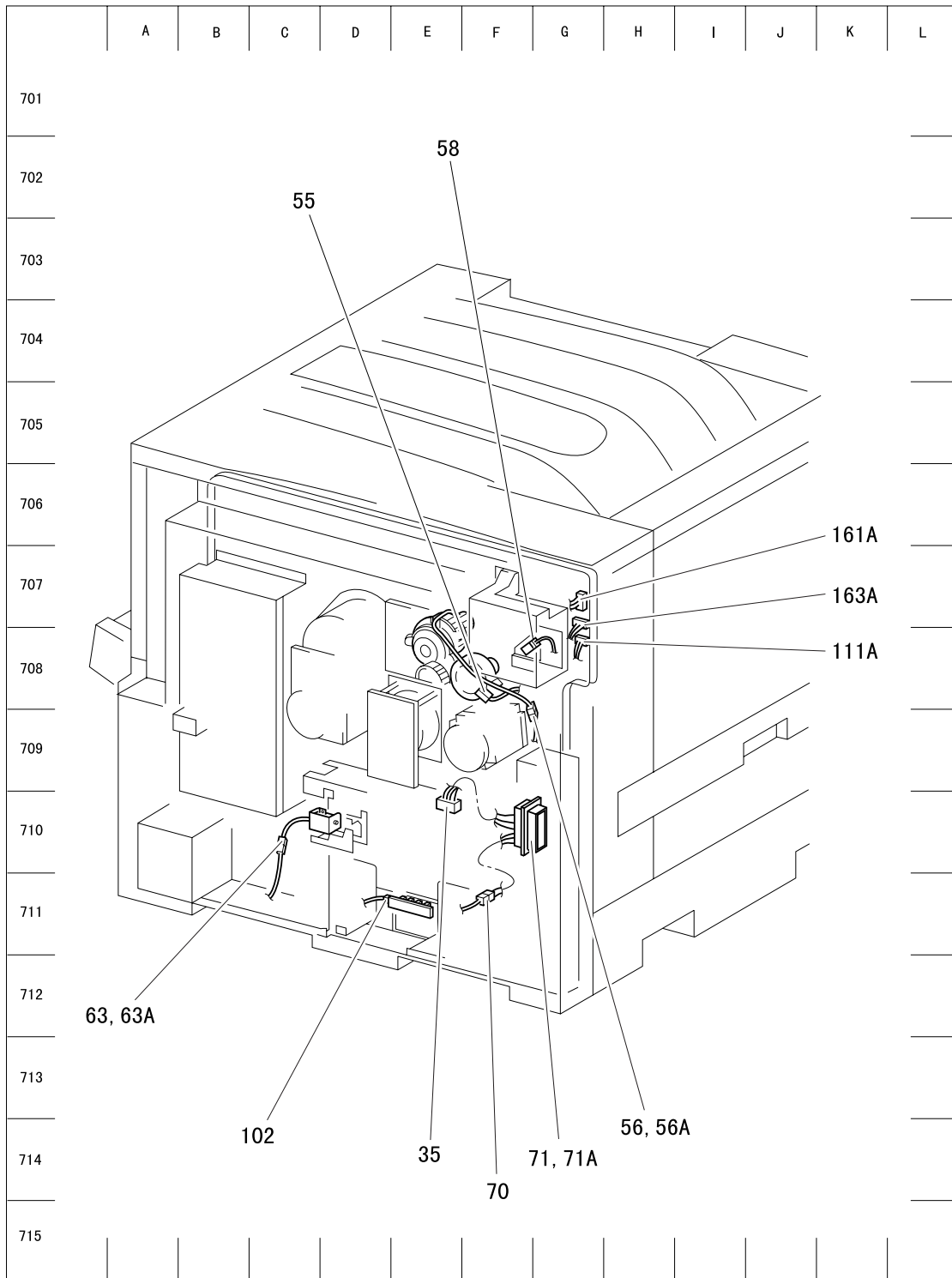

RS1107XB

RS1107XB

### P/J Location Map 8

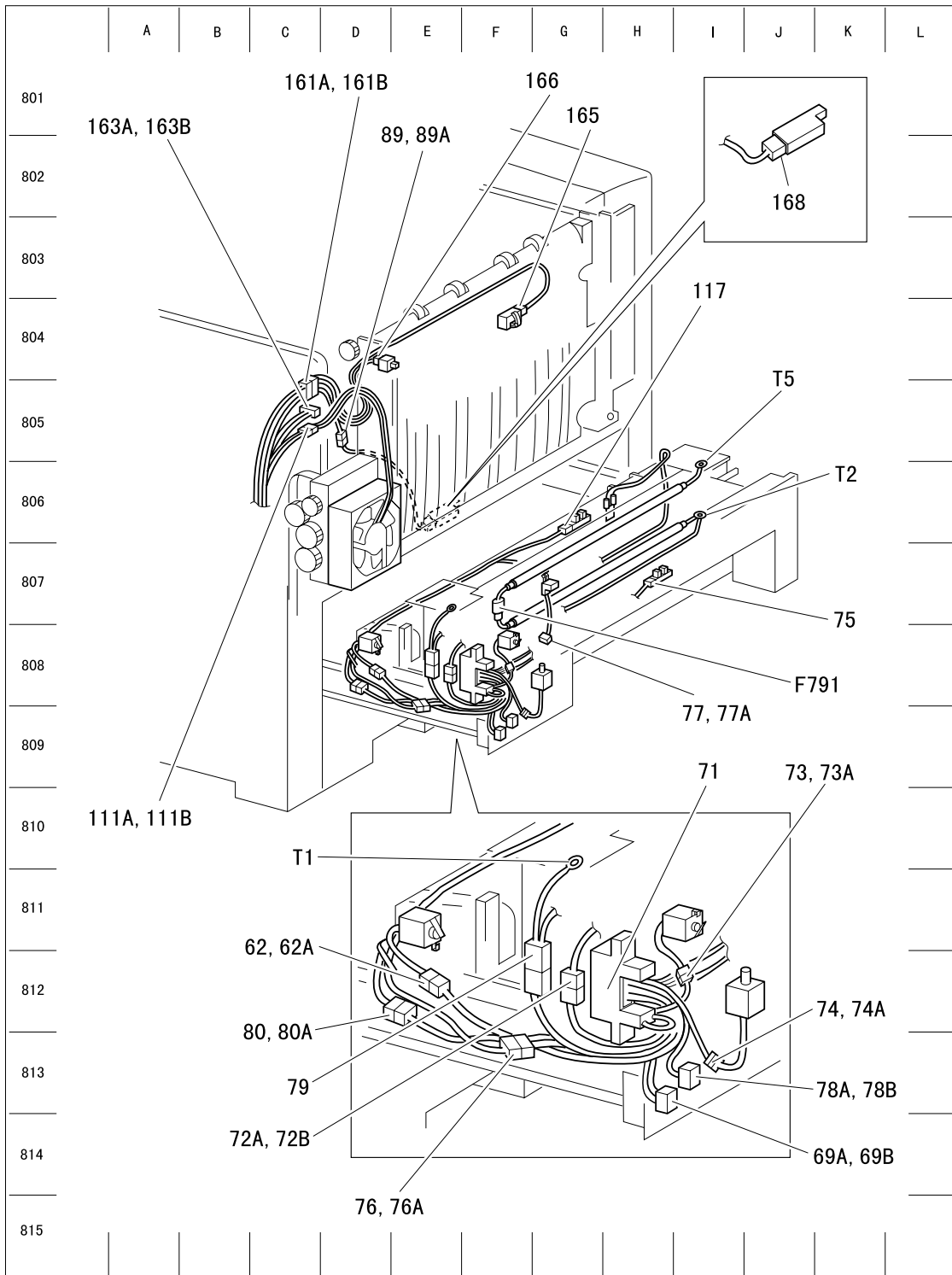

RS1108XB

RS1108XB

**Section 11 - Parts List****Contents**

PL1.1	Cover	11-4
PL2.1	Paper Tray I	11-6
PL2.2	Paper Tray II	11-8
PL3.1	Paper Feeder	11-10
PL4.1	Multi Sheet Inserter I (MSI)	11-12
PL4.2	Multi Sheet Inserter II (MSI)	11-14
PL4.3	Multi Sheet Inserter III (MSI)	11-16
PL5.1	Paper Transportation I	11-18
PL5.2	Paper Transportation II	11-20
PL6.1	Xerographics	11-22
PL7.1	Development I	11-24
PL7.2	Development II	11-26
PL8.1	IBT I	11-28
PL8.2	IBT II	11-30
PL8.3	IBT III	11-32
PL8.4	IBT IV	11-34
PL9.1	Fusing I	11-36
PL9.2	Fusing II	11-38
PL9.3	Fusing III	11-40
PL9.4	Fusing IV	11-42
PL10.1	Paper Exit I	11-44
PL10.2	Paper Exit II	11-46
PL11.1	Drive	11-48
PL12.1	Frame	11-50
PL13.1	Electrical I	11-52
PL13.2	Electrical II	11-54
PL14.1	Controller	11-56
PL30.1	Option Tray I	11-58
PL30.2	Option Tray II	11-60

## Section 11 - Parts List

---

### Using the Parts List

1. The numbers shown in each illustration correspond to the parts list number for that illustration.
2. Throughout this manual, parts are identified by the prefix “PL”, followed by a number, a decimal point, and another number. For example, PL3.12 means the part is item 12 of parts list 3.
3. The capital letters “C”, “E”, “KL”, and “S” shown in an illustration stand for C-ring, E-ring, Clamp, and Screw, respectively.
4. A shaded triangle  $t$  in an illustration indicates the item is part of an assembly.
5. The notation “**with X~Y**” following a part name indicates an assembly that is made up of components X through Y. For example, “1 (with 2~4)” means part 1 consists of part 2, part 3, and part 4.
6. An asterisk \* following a part name indicates the page contains a note about this part.
7. The notation “**J1 $\leftrightarrow$ J2 and P2**” is attached to a wire harness. It indicates that connector jack 1 is attached to one end of the wire harness and connector jack 2 is attached to the other end that is plugged into plug 2.

Blank Page

### PL1.1 Cover

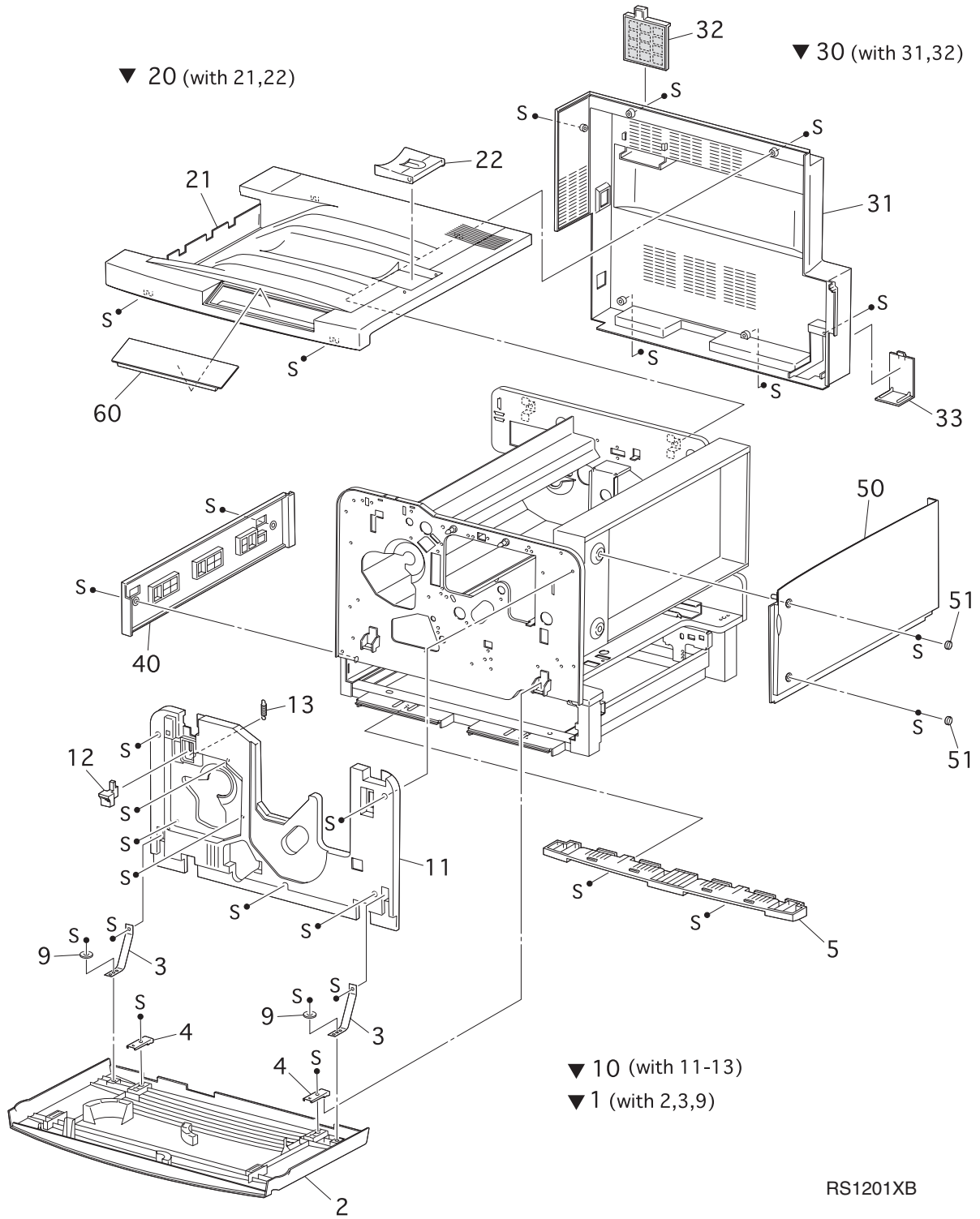



**PL1.1 Cover**

1. FRONT COVER ASSEMBLY (with 2, 3, and 9) .....	P/N 865600K69100
2. FRONT COVER SUB ASSEMBLY .....	N/A
3. COVER SUPPORT .....	N/A
4. HINGE PLATE .....	N/A
5. FRONT LOWER COVER .....	P/N 865048E52290
9. SUPPORT WASHER .....	N/A
10. INNER COVER ASSY (with 11~13) .....	P/N 865048K76171
11. INNER COVER .....	N/A
12. ROTARY LATCH LEVER .....	P/N 865600K69091
13. ROTARY LATCH SPRING .....	N/A
20. TOP COVER ASSEMBLY (with 21 and 22) .....	P/N 865802K04720
21. TOP COVER .....	N/A
22. STOPPER COVER .....	P/N 865048E49530
30. REAR COVER ASSEMBLY (with 31 and 32) .....	P/N 865600K69112
31. REAR COVER .....	N/A
32. FILTER ASSEMBLY .....	P/N 865053K91391
33. O/H COVER .....	P/N 865048E52301
40. LEFT LOWER COVER .....	P/N 865048E49570
50. RIGHT COVER ASSEMBLY .....	P/N 865048K40705
51. SCREW CAP .....	N/A
60. OPERATION PANEL .....	P/N 865048K70442

**PL2.1 Paper Tray I**

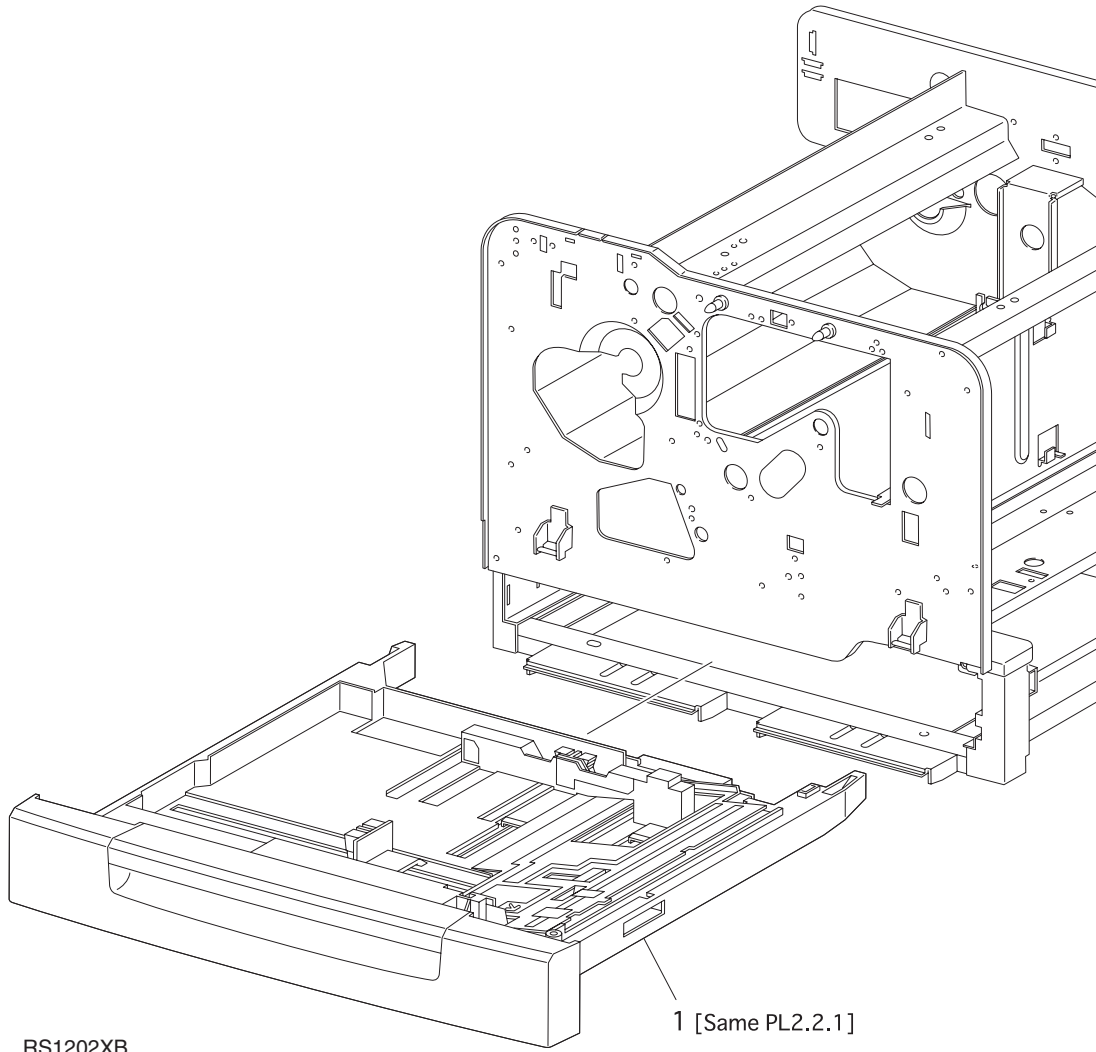

RS1202XB

1 [Same PL2.2.1]

**PL2.1 Paper Tray I**

- 1. UNIVERSAL CASSETTE (Standard Tray, same as PL2.2.1)..... P/N 1710317-001
- 1. OVERSIZE CASSETTE ..... P/N 1710318-001
- 1. OVERHEAD PROJECTION (OHP) CASSETTE ..... P/N 1710319-001

### PL2.2 Paper Tray II

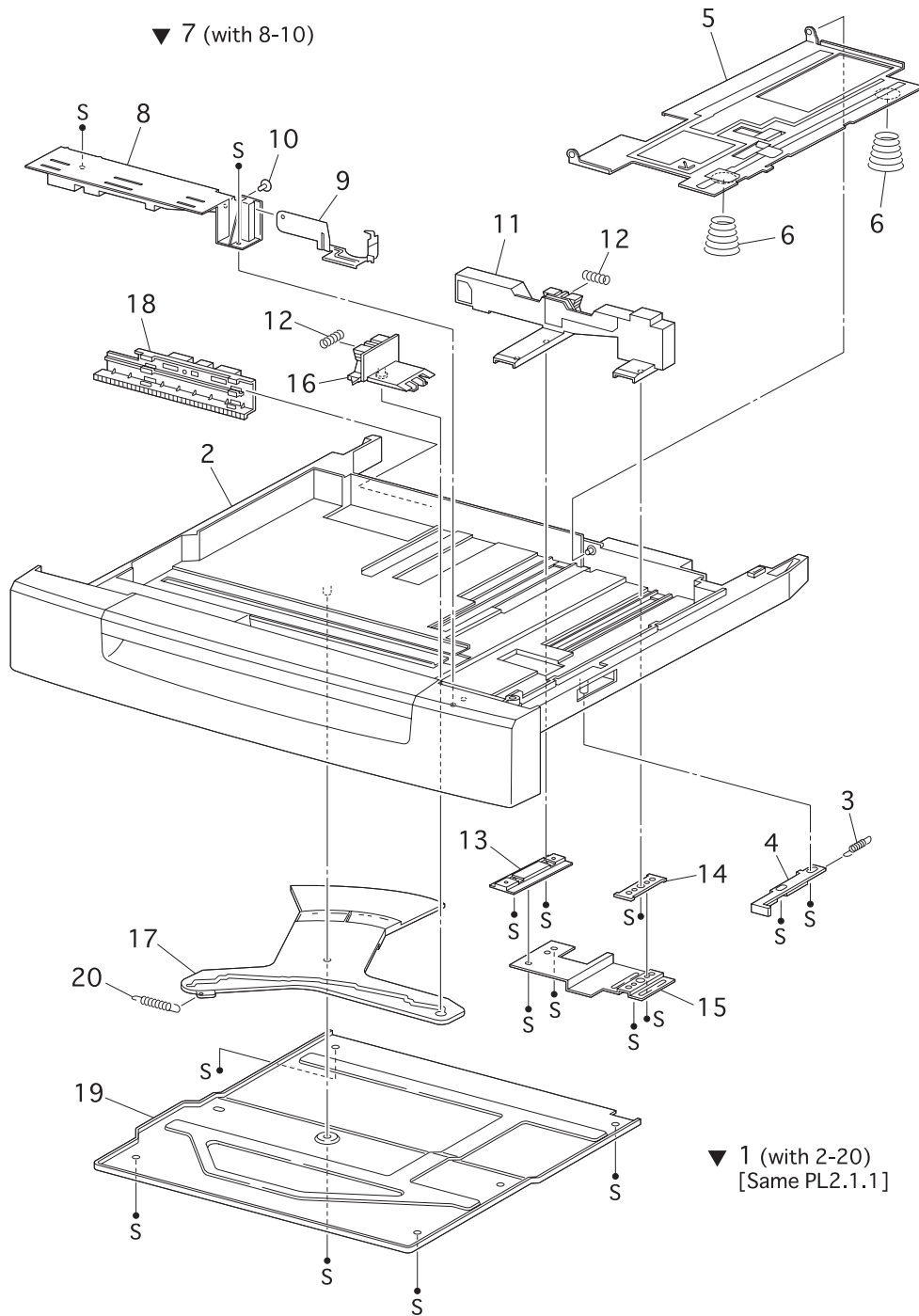

RS1203XB

**PL2.2 Paper Tray II**

1. UNIVERSAL CASSETTE (with 2~20) (Standard Tray, same as PL2.1.1).....P/N 1710317-001
2. TRAY HOUSING
3. PLATE LINK SPRING
4. PLATE LINK
5. BOTTOM PLATE ASSEMBLY
6. TRAY N/F SPRING
7. FRONT GUIDE ASSY (with 8~10)
8. FRONT GUIDE
9. FRONT SNUBBER
10. SNUBBER STOPPER
11. REAR GUIDE ASSEMBLY
12. GUIDE SPRING
13. REAR GUIDE PLATE L
14. REAR GUIDE PLATE R
15. LOCK PLATE
16. END GUIDE
17. SECTOR GEAR
18. TRAY SIZE ACTUATOR
19. TRAY BOTTOM COVER
20. SECTOR GEAR SPRING

### PL3.1 Paper Feeder

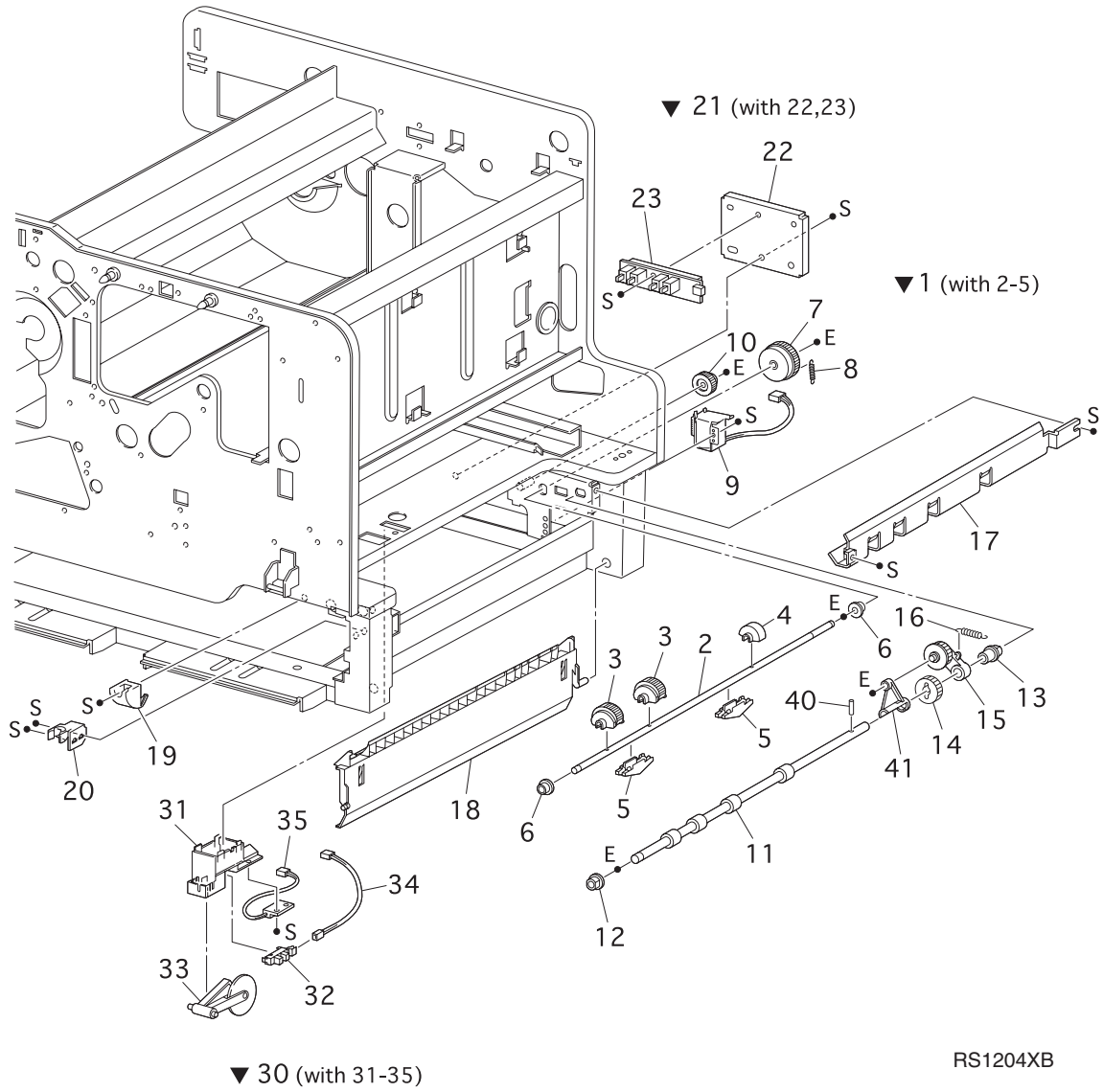

**PL3.1 Paper Feeder**

1. FEED ROLL ASSEMBLY (with 2~5).....	P/N 865048E52290
2. FEED SHAFT .....	N/A
3. FEED ROLL .....	P/N 865600K73770
4. FEED CORE ROLL .....	N/A
5. FEED ROLL GUIDE .....	N/A
6. FEED BEARING.....	P/N 865013E80210
7. FEED GEAR .....	P/N 865007E38620
8. FEED SPRING .....	P/N 865009E71750
9. FEED SOLENOID .....	P/N 865121E84500
10. FEED IDLER GEAR.....	N/A
11. TURN ROLL ASSEMBLY (WITH 12-15, & 41-42) .....	P/N 865600K68591
12. TURN FRONT BEARING.....	N/A
13. TURN REAR BEARING .....	N/A
14. TURN GEAR.....	N/A
15. TURN ARM ASSEMBLY .....	N/A
16. TURN ARM SPRING .....	N/A
17. TURN CHUTE.....	N/A
18. TURN IN CHUTE .....	P/N 865054E06750
19. FEED SHAFT GUIDE.....	N/A
20. TRAY STOPPER.....	P/N 865003E37250
21. SIZE BRACKET ASSEMBLY (with 22 and 23).....	N/A
22. SIZE SWITCH BRACKET .....	N/A
23. SIZE SWITCH ASSEMBLY .....	P/N 865110K07770
30. TRAY N/P SENSOR ASSEMBLY (with 31~35) .....	P/N 865015K21292
31. TRAY N/P BRACKET.....	N/A
32. TRAY NO PAPER SENSOR.....	N/A
33. TRAY N/P ACTUATOR .....	N/A
34. TRAY N/P HARNESS .....	N/A
35. LOW PAPER SENSOR (factory installed option).....	N/A
40. TURN GEAR PIN .....	N/A
41. TURN ARM SUPPORT .....	N/A

**PL4.1 Multi Sheet Inserter I (MSI)**

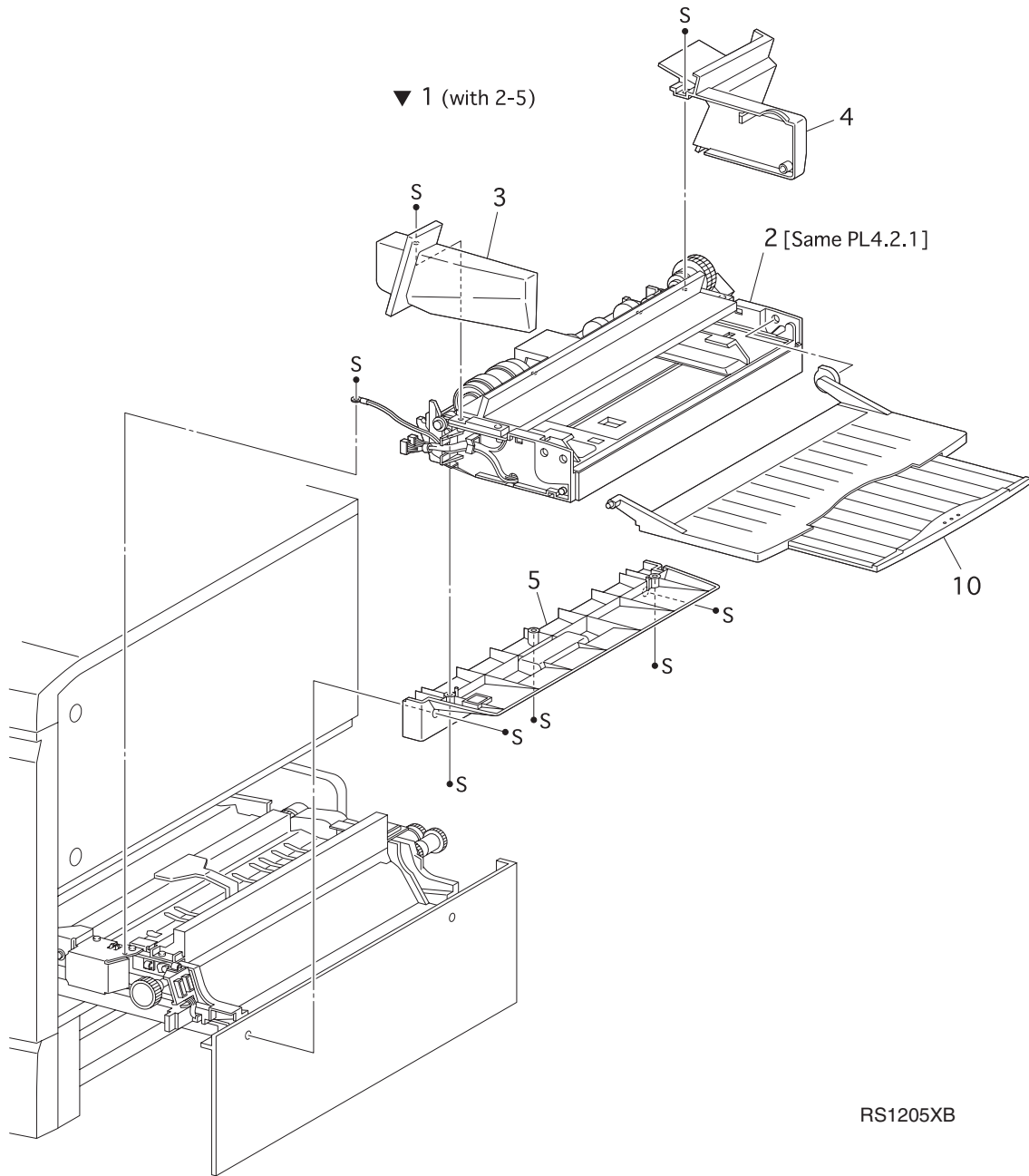

RS1205XB



**PL4.1 Multi Sheet Inserter I (MSI)**

1. MSI ASSEMBLY (with 2~5) ..... P/N 865600K70231
2. MSI FRAME ASSEMBLY (same as PL4.2.1)..... P/N 865600K70231
3. MSI FRONT COVER ..... P/N 865048E48450
4. MSI REAR COVER..... P/N 865048E48462
5. MSI HOLDER..... P/N 865019E32251
10. MSI TRAY ASSEMBLY ..... P/N 865050K36351

### PL4.2 Multi Sheet Inserter II (MSI)

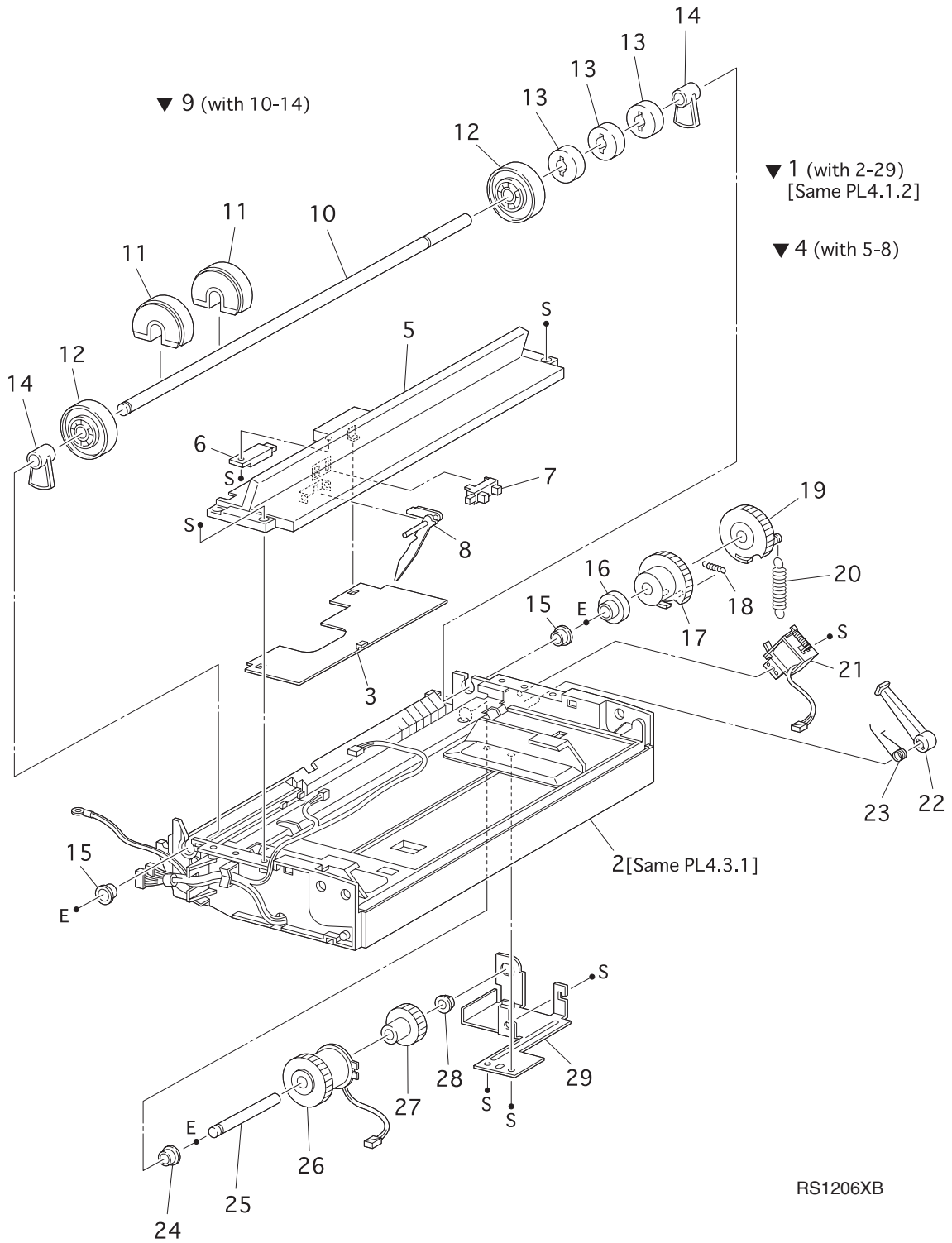

**PL4.2 Multi Sheet Inserter II (MSI)**

1. MSI FRAME ASSEMBLY (with 2~29) (same as PL 4.1.2).....	P/N 865600K70230
2. MSI SUB ASSEMBLY .....	N/A
3. MSI HARNESS COVER .....	N/A
4. MSI TOP COVER ASSEMBLY (with 5~8) .....	N/A
5. MSI TOP COVER .....	N/A
6. MSI EDGE SENSOR .....	P/N 865130E82650
7. MSI SHORT N/P SENSOR .....	P/N 865130E81970
8. MSI N/P ACTUATOR.....	P/N 865120E11971
9. MSI ROLL ASSEMBLY (with 10~14).....	P/N 865600K73780
10. PICK UP SHAFT.....	N/A
11. PICK UP ROLL .....	N/A <a href="#">865059K94210</a>
12. FRONT CORE ROLL .....	N/A
13. REAR CORE ROLL .....	N/A
14. PICK UP CAM.....	N/A
15. MSI BEARING .....	N/A
16. LEVER STOPPER .....	N/A
17. PICK UP CAM GEAR .....	P/N 865007E40320
18. CAM GEAR SPRING .....	P/N 865009E64291
19. PICK UP GEAR .....	P/N 865007E40310
20. PICK UP SPRING.....	P/N 865809E07171
21. PICK UP SOLENOID .....	P/N 865121K88130
22. GEAR LEVER.....	N/A
23. GEAR LEVER SPRING .....	N/A
24. MSI FRONT BEARING .....	N/A
25. MSI SHAFT .....	N/A
26. MSI CLUTCH .....	P/N 865121E84690
27. MSI GEAR .....	P/N 865007E45760
28. MSI REAR BEARING.....	N/A
29. CLUTCH BRACKET.....	N/A

### PL4.3 Multi Sheet Inserter III (MSI)

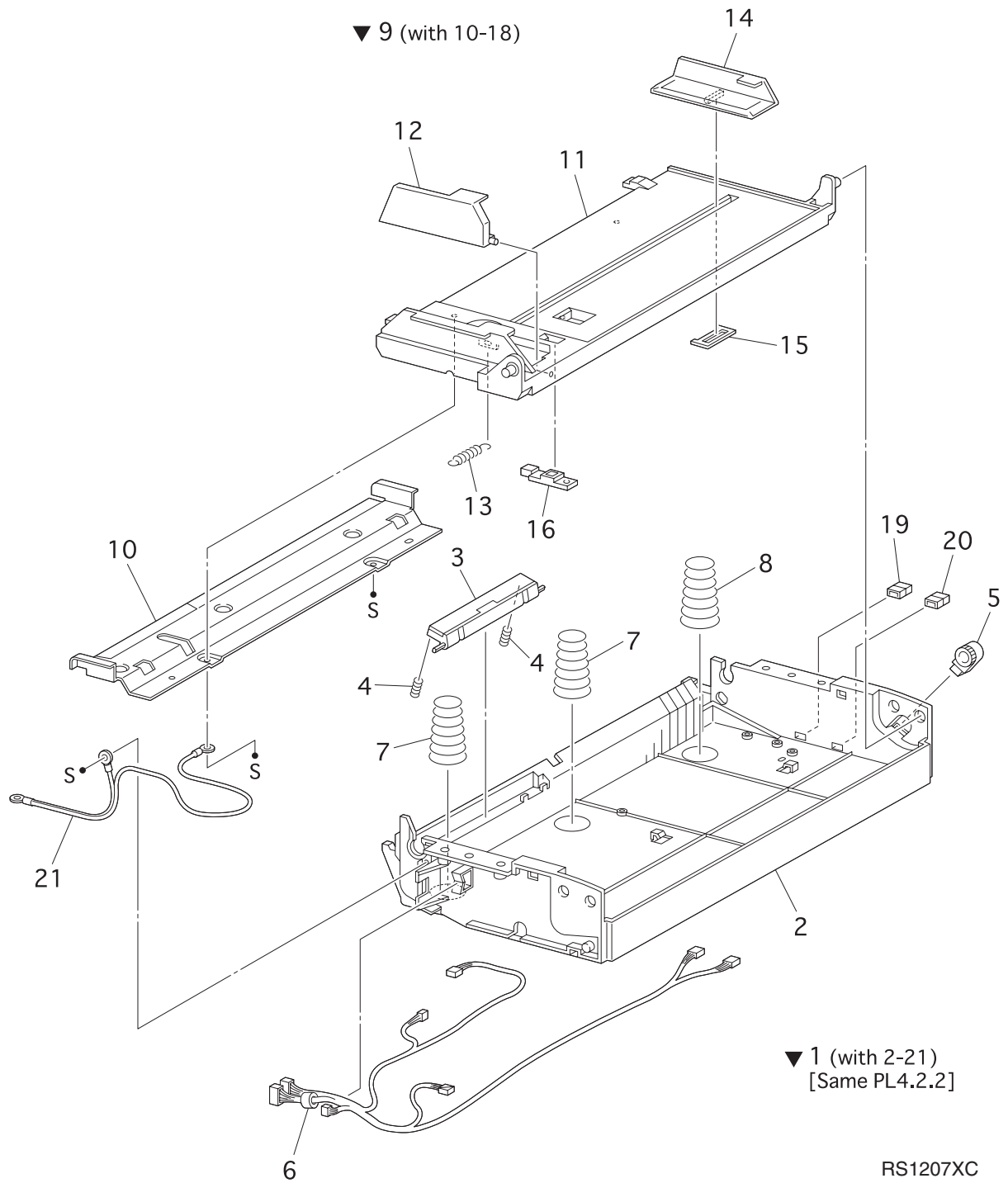

**PL4.3 Multi Sheet Inserter III (MSI)**

1. MSI SUB ASSEMBLY (with 2~21) .....	P/N 865600K70230
2. MSI FRAME .....	N/A
3. RETARD PAD ASSEMBLY .....	P/N 865600K68760
4. RETARD SPRING .....	N/A
5. OIL DAMPER GEAR .....	N/A
6. MSI HARNESS ASSEMBLY .....	N/A
7. MSI N/F FRONT SPRING .....	N/A
8. MSI N/F REAR SPRING .....	N/A
9. MSI BOTTOM ASSEMBLY (with 10~18) .....	N/A
10. MSI BOTTOM PLATEN/A .....	N/A
11. MSI BASE TRAY .....	N/A
12. MSI FRONT GUIDE .....	N/A
13. MSI GUIDE SPRING .....	N/A
14. MSI REAR GUIDE .....	N/A
15. GUIDE BLOCK .....	N/A
16. MSI LONG N/P SENSOR .....	N/A
19. CONNECTOR-2PW .....	N/A
20. CONNECTOR-2PB .....	N/A
21. MSI EARTH WIRE .....	N/A

### PL5.1 Paper Transportation I

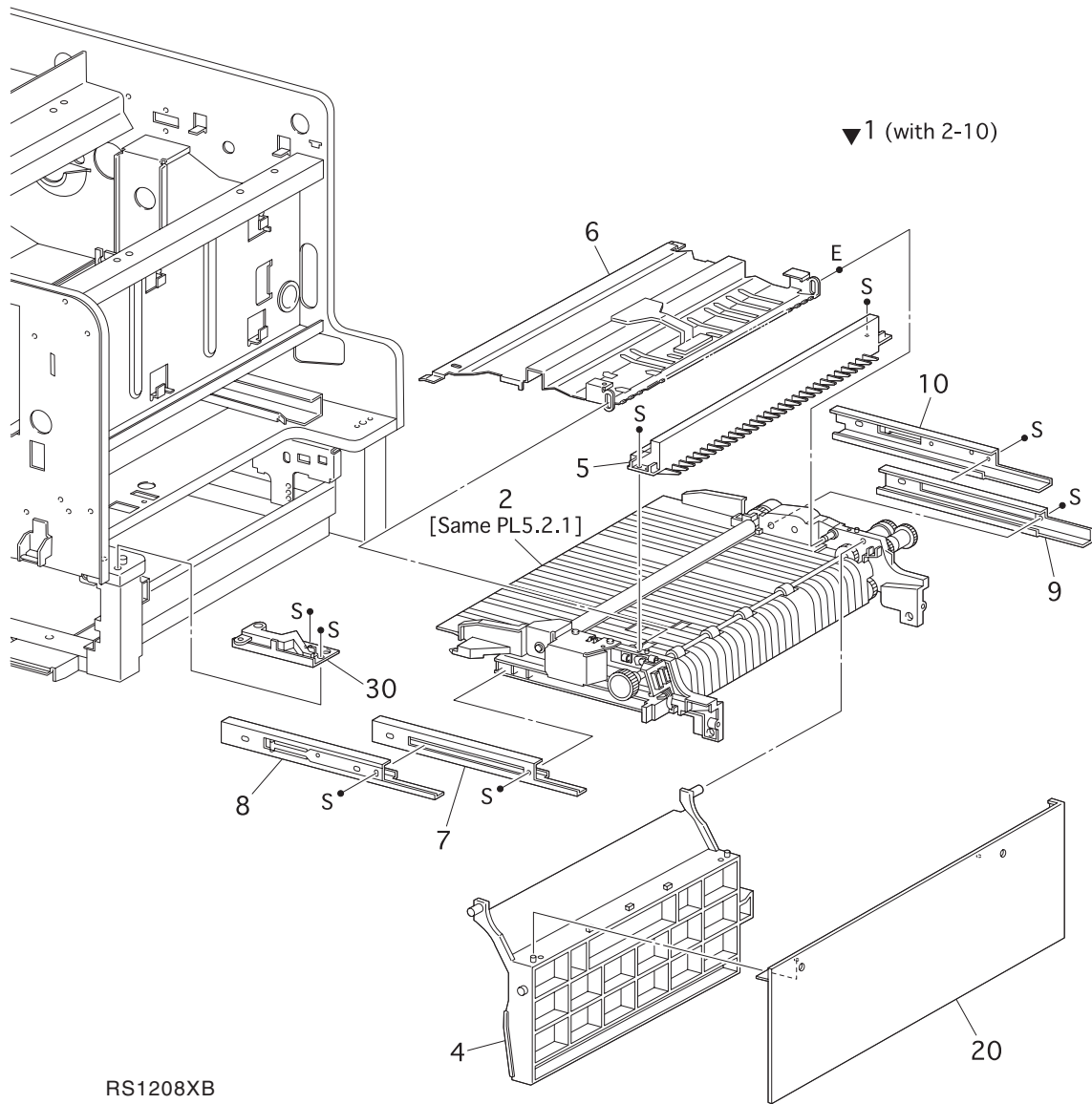

**PL5.1 Paper Transportation I**

1. MAIN P/H ASSEMBLY (with 2~10) .....	N/A
2. MAIN P/H SUB ASSEMBLY (Same as PL 5.2.1) .....	N/A
4. P/H TURN CHUTE ASSEMBLY .....	P/N 865054K06742
5. PRE-REGISTRATION CHUTE ASSEMBLY .....	N/A
6. REGISTRATION CHUTE ASSEMBLY .....	N/A
7. P/H FRONT RAIL-S .....	N/A
8. P/H FRONT RAIL-L .....	N/A
9. P/H REAR RAIL-S .....	N/A
10. P/H REAR RAIL-L .....	N/A
20. MAIN P/H COVER .....	N/A
30. LATCH ARM ASSEMBLY .....	P/N 865031K92400

### PL5.2 Paper Transportation II

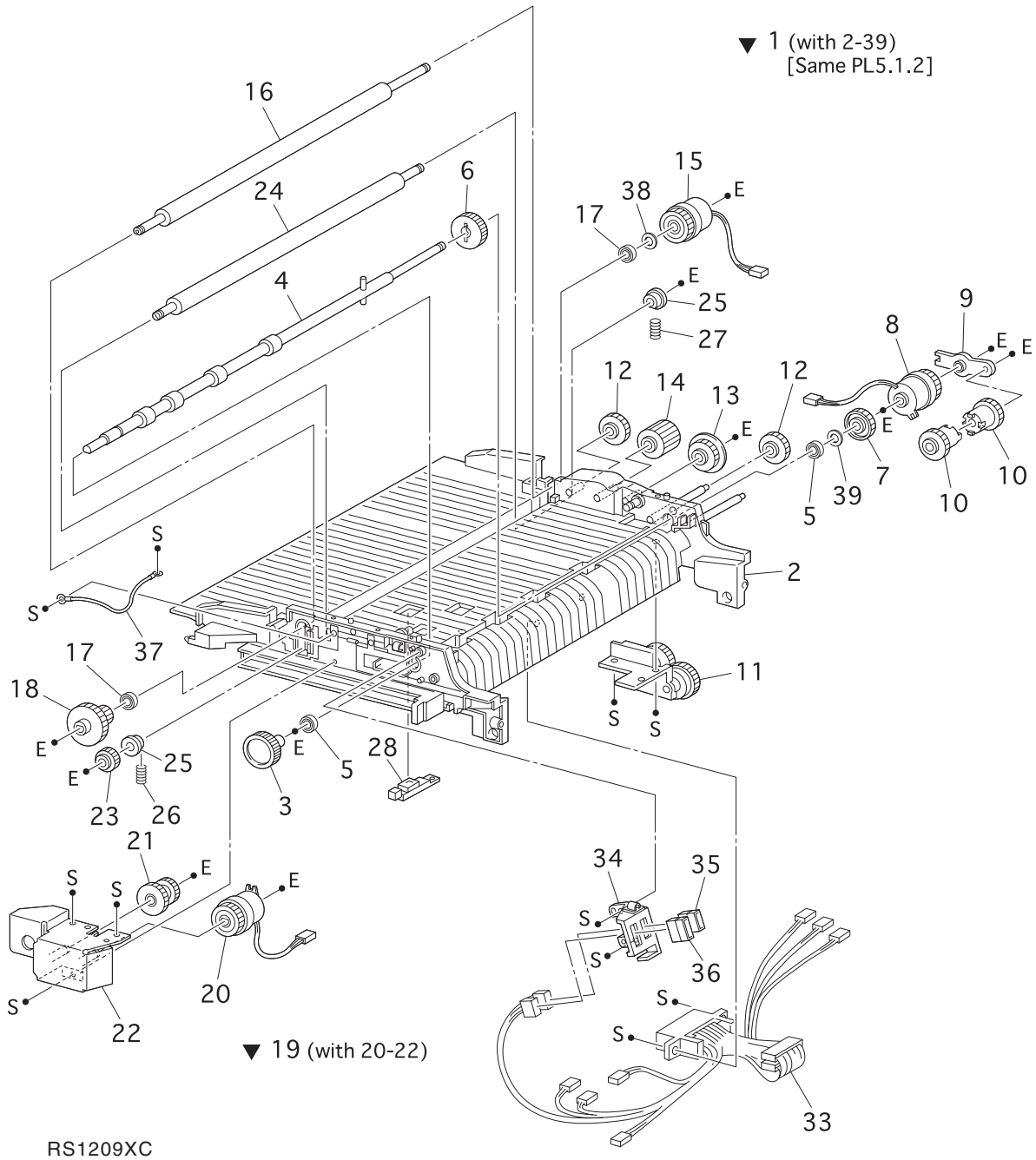



**PL5.2 Paper Transportation II**

1. MAIN P/H SUB ASSEMBLY (with 2~39) - (Same as PL 5.1.2).....	N/A
2. P/H FRAME ASSEMBLY .....	N/A
3. PRE-REGISTRATION KNOB ASSEMBLY .....	P/N 865003E37710
4. PRE-REGISTRATION ROLL ASSEMBLY .....	P/N 865059K04760
5. PRE-REGISTRATION BEARING .....	N/A
6. PRE-REGISTRATION GEAR 2 .....	N/A
7. TURN IDLER GEAR.....	N/A
8. PRE-REGISTRATION CLUTCH .....	P/N 865121K16830
9. PRE-REGISTRATION SUPPORT.....	N/A
10. PRE-REGISTRATION GEAR 1 .....	N/A
11. PRE-RREGISTRATION GEAR ASSEMBLY .....	N/A
12. PRE-REGISTRATION GEAR 3 .....	N/A
13. PRE-RREGISTRATION GEAR 5 .....	N/A
14. PRE-REGISTRATION GEAR 6.....	N/A
15. REGISTRATION CLUTCH .....	P/N 865121K12410
16. REGISTRATION METAL ROLL .....	N/A
17. REGISTRATION UPPER BEARING .....	N/A
18. REGISTRATION OUT GEAR .....	N/A
19. REGISTRATION BRAKE ASSEMBLY (with 20~22) .....	N/A
20. REGISTRATION BRAKE CLUTCH .....	N/A
21. REGISTRATION BRAKE GEAR .....	N/A
22. REGISTRATION BRAKE BRACKET .....	N/A
23. REGISTRATION GEAR .....	N/A
24. REGISTRATION RUBBER ROLL .....	P/N 865059K04770
25. REGISTRATION LOWER BEARING .....	N/A
26. REGISTRATION FRONT SPRING .....	P/N 865600K68610
27. REGISTRATION REAR SPRING .....	N/A
28. REGISTRATION SENSOR .....	N/A
33. REGISTRATION HARNESS ASSEMBLY .....	N/A
34. MSI OUT HOLDER .....	N/A
35. CONNECTOR-6PW .....	N/A
36. CONNECTOR-7PW .....	N/A
37. REGISTRATION EARTH WIRE .....	N/A
38. REGISTRATION SPACER .....	N/A
39. PRE-REGISTRATION SPACER .....	N/A

### PL6.1 Xerographics

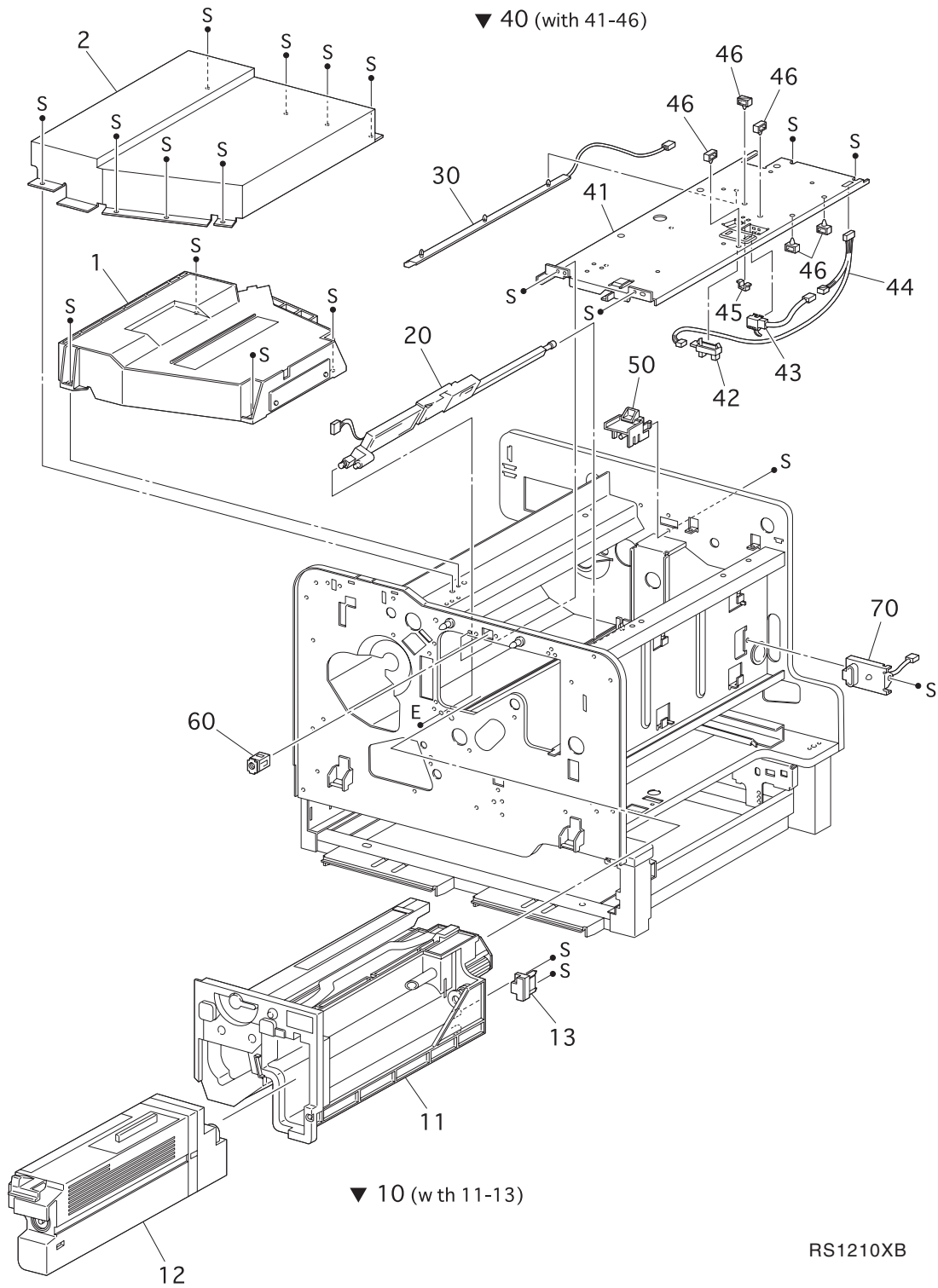

**PL6.1 Xerographics**

1. ROS ASSEMBLY .....	P/N 865062K98331
2. ROS COVER .....	N/A
3. ROS PLATE .....	N/A
10. DRUM CARTRIDGE (with 11 ~ 13) .....	P/N 1710323-001
11. XEROGRAPHIC CARTRIDGE .....	N/A
12. WASTE TONER BOX .....	P/N 1710324-001
13. CRUM ASSEMBLY (factory installed option) .....	N/A
20. ADC SENSOR ASSEMBLY .....	P/N 865130K86322
30. ERASE LAMP ASSEMBLY .....	P/N 865122K92440
40. XL RAIL ASSEMBLY (with 41~46).....	N/A
41. XL RAIL.....	N/A
42. WASTE TONER SENSOR .....	P/N 865130E91010
43. TONER BOX SENSOR .....	P/N 865130E82980
44. TONER BOX HARNESS .....	N/A
45. RAIL CLAMP-1 .....	N/A
46. RAIL CLAMP-2 .....	N/A
50. BCR CONNECTOR ASSEMBLY .....	P/N 865600K68620
60. RECEPTACLE ASSEMBLY .....	N/A
70. CRUM CONNECTOR ASSEMBLY (factory installed option) .....	P/N 865113K81450

### PL7.1 Development I

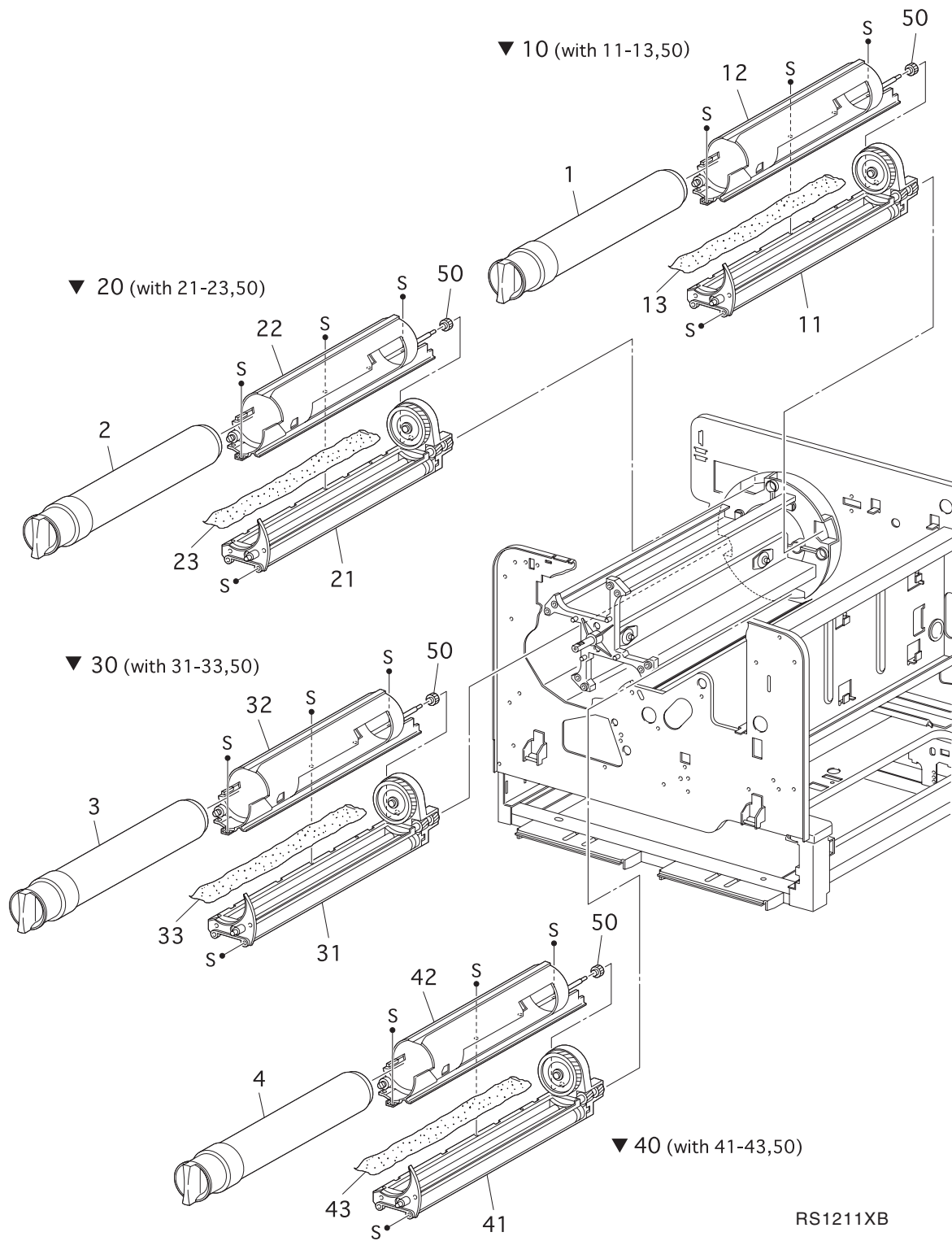

**PL7.1 Development I**

1. TONER CARTRIDGE Y .....	P/N 1710322-033
2. TONER CARTRIDGE M.....	P/N 1710322-004
3. TONER CARTRIDGE C.....	P/N 1710322-002
4. TONER CARTRIDGE BK.....	P/N 1710322-001
10. DEVELOPER ASSEMBLY Y (with 11~13, and 50) .....	P/N 865600K69892
11. DEVELOPER LOWER ASSEMBLY Y .....	N/A
12. DEVELOPER UPPER ASSEMBLY Y.....	N/A
13. DEVELOPER Y .....	N/A
20. DEVELOPER ASSEMBLY M (with 21~23, and 50) .....	P/N 865600K69902
21. DEVELOPER LOWER ASSEMBLY M .....	N/A
22. DEVELOPER UPPER ASSEMBLY M.....	N/A
23. DEVELOPER M .....	N/A
30. DEVELOPER ASSEMBLY C (with 31~33, and 50).....	P/N 865600K69912
31. DEVELOPER LOWER ASSEMBLY C .....	N/A
32. DEVELOPER UPPER ASSEMBLY C.....	N/A
33. DEVELOPER C .....	N/A
40. DEVELOPER ASSEMBLY BK (with 41~43, and 50).....	P/N 865600K69882
41. DEVELOPER LOWER ASSEMBLY BK .....	N/A
42. DEVELOPER UPPER ASSEMBLY BK.....	N/A
43. DEVELOPER BK .....	N/A
50. AUGER DISPENSE GEAR.....	N/A

### PL7.2 Development II

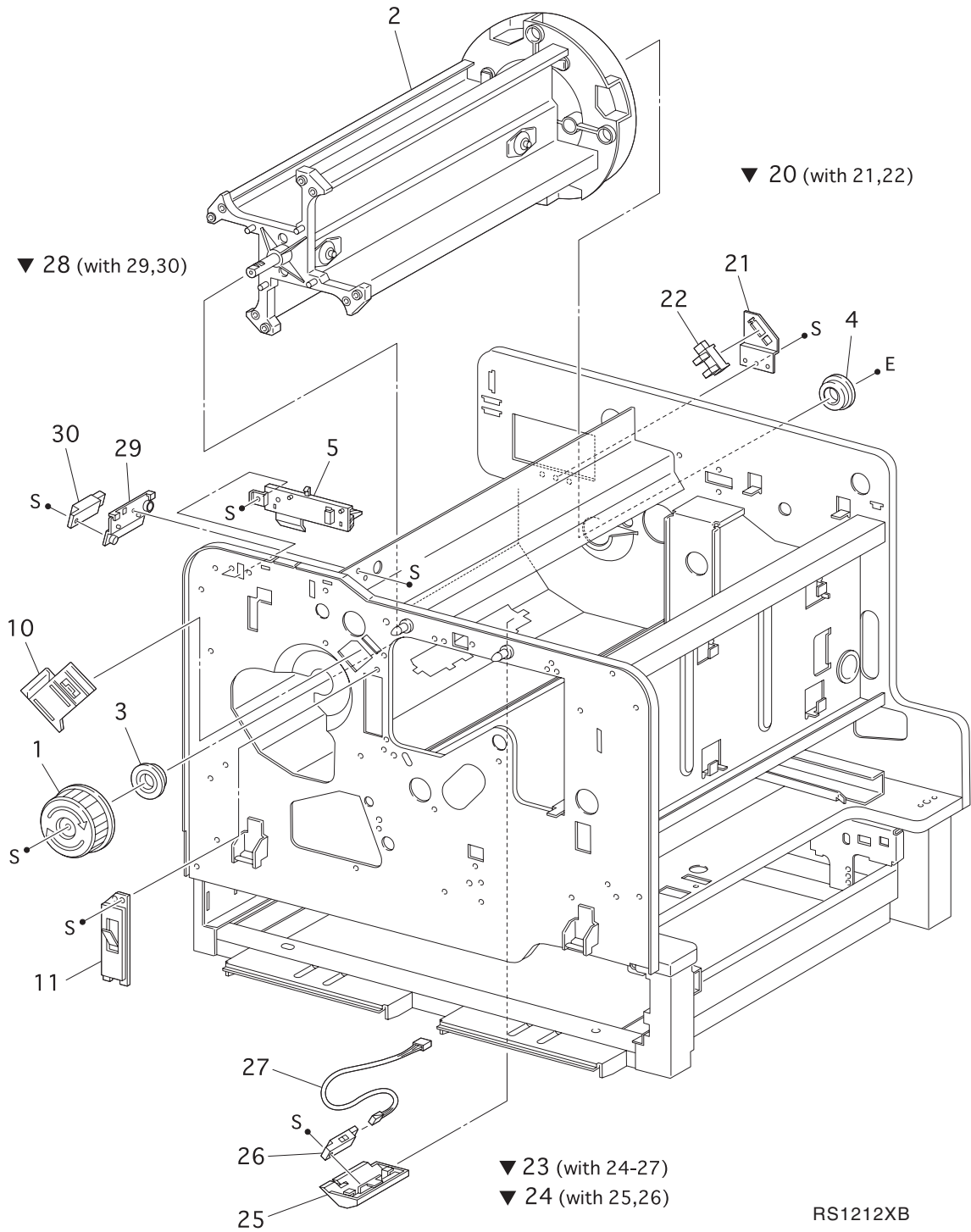

**PL7.2 Development II**

1. ROTARY KNOB ASSEMBLY .....	P/N 865003K84303
2. ROTARY FRAME ASSEMBLY.....	N/A
3. ROTARY FRONT BEARING .....	N/A
4. ROTARY REAR BEARING.....	N/A
5. ROTARY LATCH ASSEMBLY.....	N/A
10. DEVELOPER DISCHARGE ASSEMBLY .....	N/A
11. DEVELOPER CONTACT ASSEMBLY .....	P/N 865600K68630
20. ROTARY SENSOR ASSEMBLY (with 21 and 22).....	N/A
21. ROTARY SENSOR PLATE.....	N/A
22. ROTARY SENSOR .....	P/N 865130E83060
23. CARTRIDGE SENSOR H ASSEMBLY (with 24 ~ 27).....	N/A
24. CARTRIDGE SENSOR ASSEMBLY (with 25 and 26).....	N/A
25. CARTRIDGE SENSOR HOLDER .....	N/A
26. CARTRIDGE SENSOR .....	P/N 865130E83090
27. CARTRIDGE SENSOR HARNESS .....	N/A
28. USED SENSOR ASSEMBLY (with 29 and 30).....	N/A
29. USED SENSOR PLATE .....	N/A
30. USED CARTRIDGE SENSOR .....	P/N 865130E82830

**PL8.1 IBT 1**

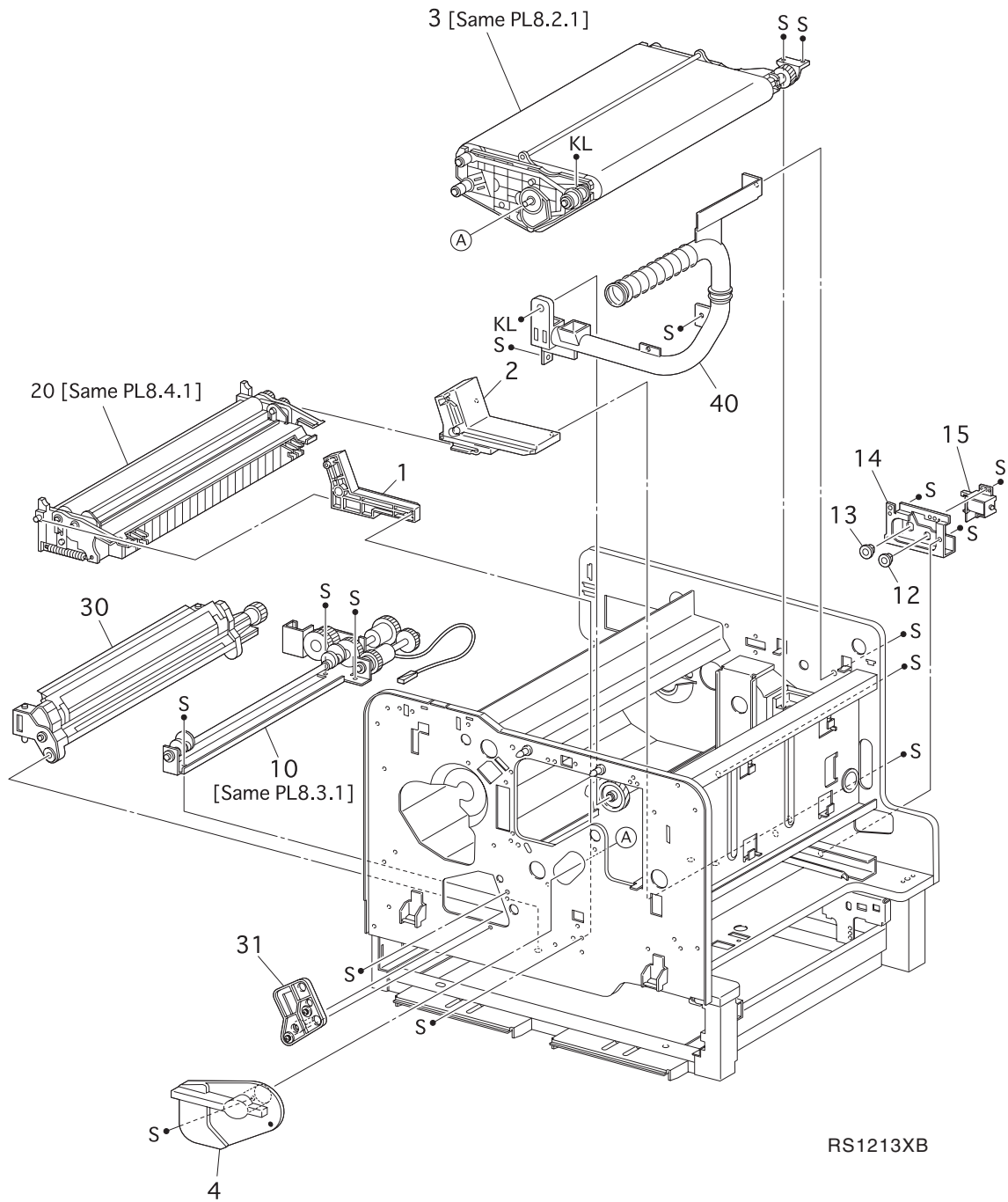



**PL8.1 IBT 1**

1. IBT FRONT BRACKET .....	N/A
2. IBT REAR BRACKET .....	N/A
3. TRANSFER ASSEMBLY (same as PL 8.2.1).....	P/N 865048K74572
4. TENSION LEVER .....	P/N 865011K94460
5. IBT BRACKET .....	N/A
10. 2ND BTR CAM ASSEMBLY (same as PL 8.3.1).....	P/N 865008K91354
12. BTR BEARING-4 .....	N/A
13. BTR BEARING-6 .....	N/A
14. BTR SIDE BRACKET .....	N/A
15. BTR CAM SOLENOID .....	P/N 865121E84291
20. 2ND BTR ASSEMBLY (same as PL 8.4.1) (mandatory replacement part) .....	P/N 865600K68710
30. BELT CLEANER ASSEMBLY (mandatory replacement part).....	P/N 865600K68641
31. CLEANER SUPPORT ASSEMBLY .....	N/A
40. AUGER HIGH ASSEMBLY .....	P/N 865006K82811

**number 20 is an assy with number 12,13,14 and 20**

**PL8.2 IBT II**

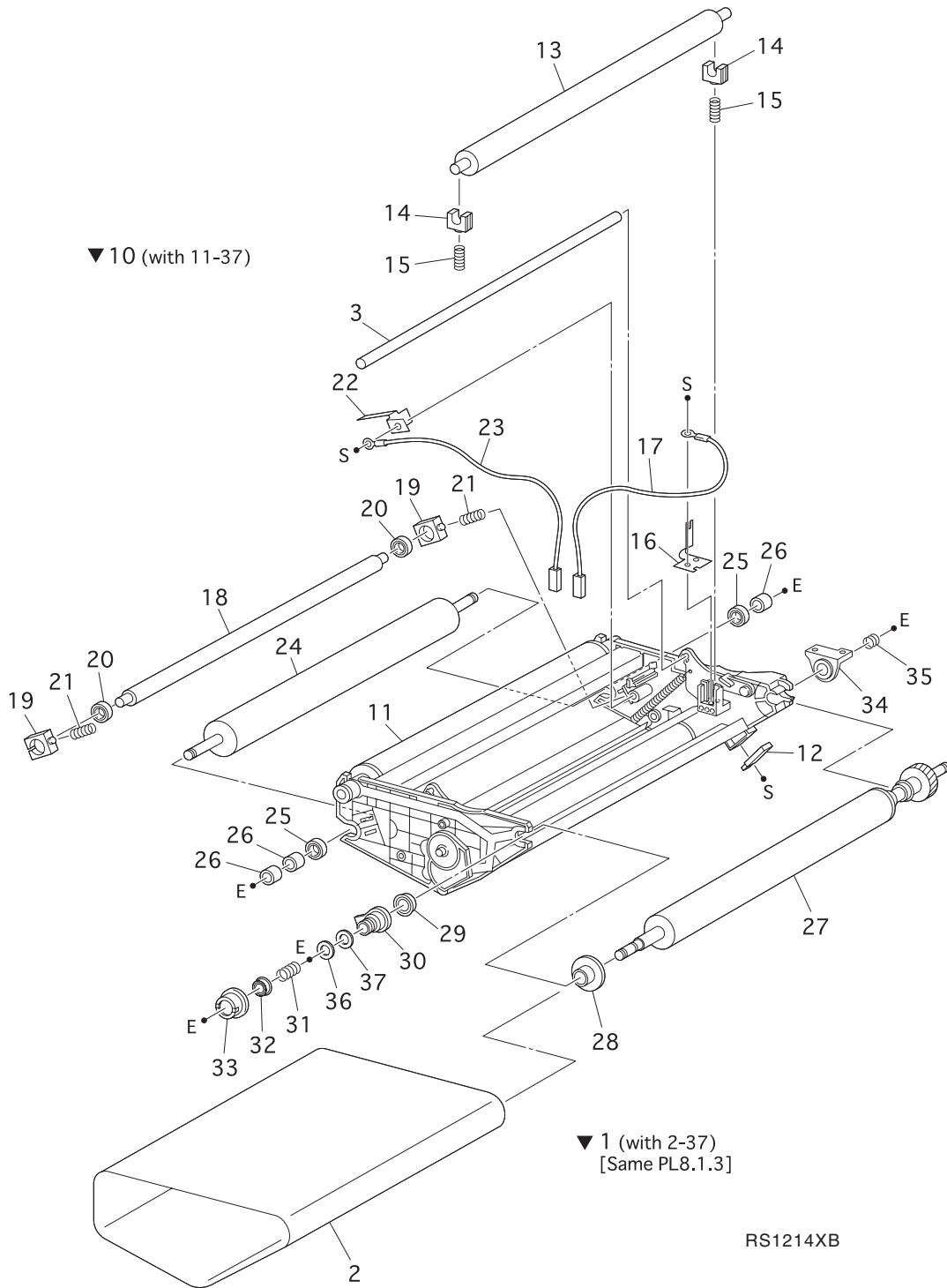

**PL8.2 IBT II**

1. TRANSFER ASSEMBLY (with 2~37) (same as PL 8.1.3) .....	P/N 865048K74572
2. IBT BELT ASSEMBLY .....	P/N 865064K91281
3. PUSH IN SHAFT .....	N/A
10. TRANSFER MECH ASSEMBLY (with 11~37).....	N/A
11. TRANSFER SUB ASSEMBLY .....	N/A
12. TR0 SENSOR.....	N/A
13. 1ST BTR.....	N/A
14. 1ST BTR BEARING .....	N/A
15. 1ST BTR SPRING.....	N/A
16. 1ST BTR BIAS PLATE.....	N/A
17. 1ST BTR WIRE.....	N/A
18. CONTACT ROLL .....	N/A
19. CONTACT ROLL BEARING .....	N/A
20. IBT BEARING-1.....	N/A
21. CONTACT ROLL SPRING .....	N/A
22. CONTACT PLATE.....	N/A
23. CONTACT ROLL WIRE .....	N/A
24. BACK UP ROLL.....	N/A
25. IBT BEARING-2.....	N/A
26. COLLAR-BUR.....	N/A
27. IBT DRIVE ROLL ASSEMBLY .....	N/A
28. DRIVE ROLL FLANGE.....	N/A
29. IBT BEARING-3.....	N/A
30. D/R FRONT COLLAR .....	N/A
31. D/R FRONT SPRING .....	N/A
32. IBT BEARING-4.....	N/A
33. SLIDE COLLAR.....	N/A
34. D/R BEARING ASSEMBLY .....	N/A
35. D/R REAR SPRING.....	N/A
36. IBT SPACER-1.....	N/A
37. IBT SPACER-2 (Use two to reduce rattle in the IBT Drive Roll Assembly).....	N/A

**PL8.3 IBT III**

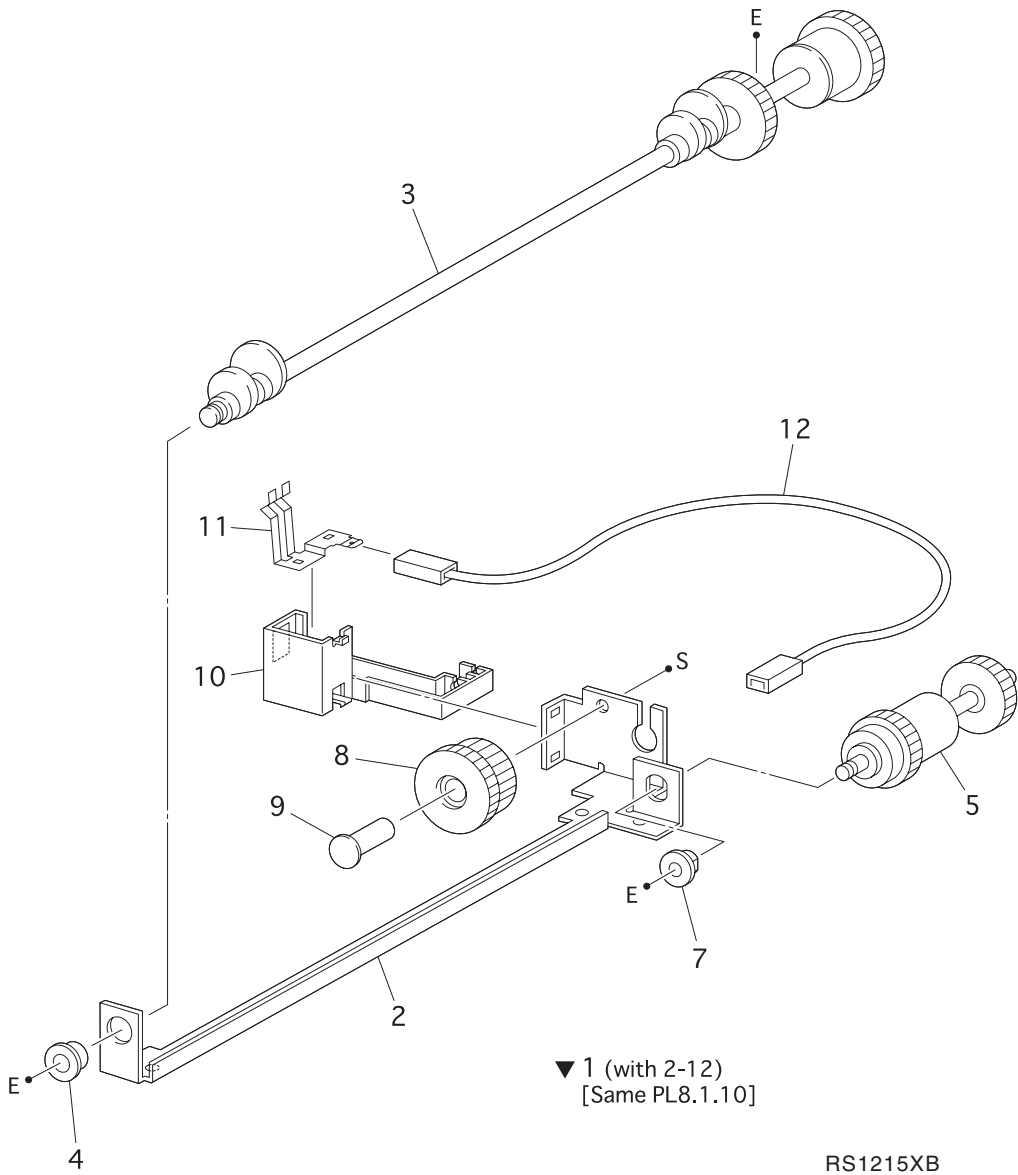

**PL8.3 IBT III**

1. 2ND BTR CAM ASSEMBLY (with 2~12) (same as PL 8.1.10).....	P/N 865008K91354
2. BTR CAM BRACKET.....	N/A
3. BTR CAM ASSEMBLY.....	N/A
4. BTR CAM BEARING.....	N/A
5. TORQUE GEAR ASSEMBLY.....	N/A
7. BTR BEARING-4.....	N/A
8. 2ND BTR GEAR B1.....	N/A
9. GEAR B1 SHAFT.....	N/A
10. DTS CONTACT HOLDER.....	N/A
11. DTS PLATE.....	N/A
12. DTS WIRE.....	N/A

PL8.4 IBT IV

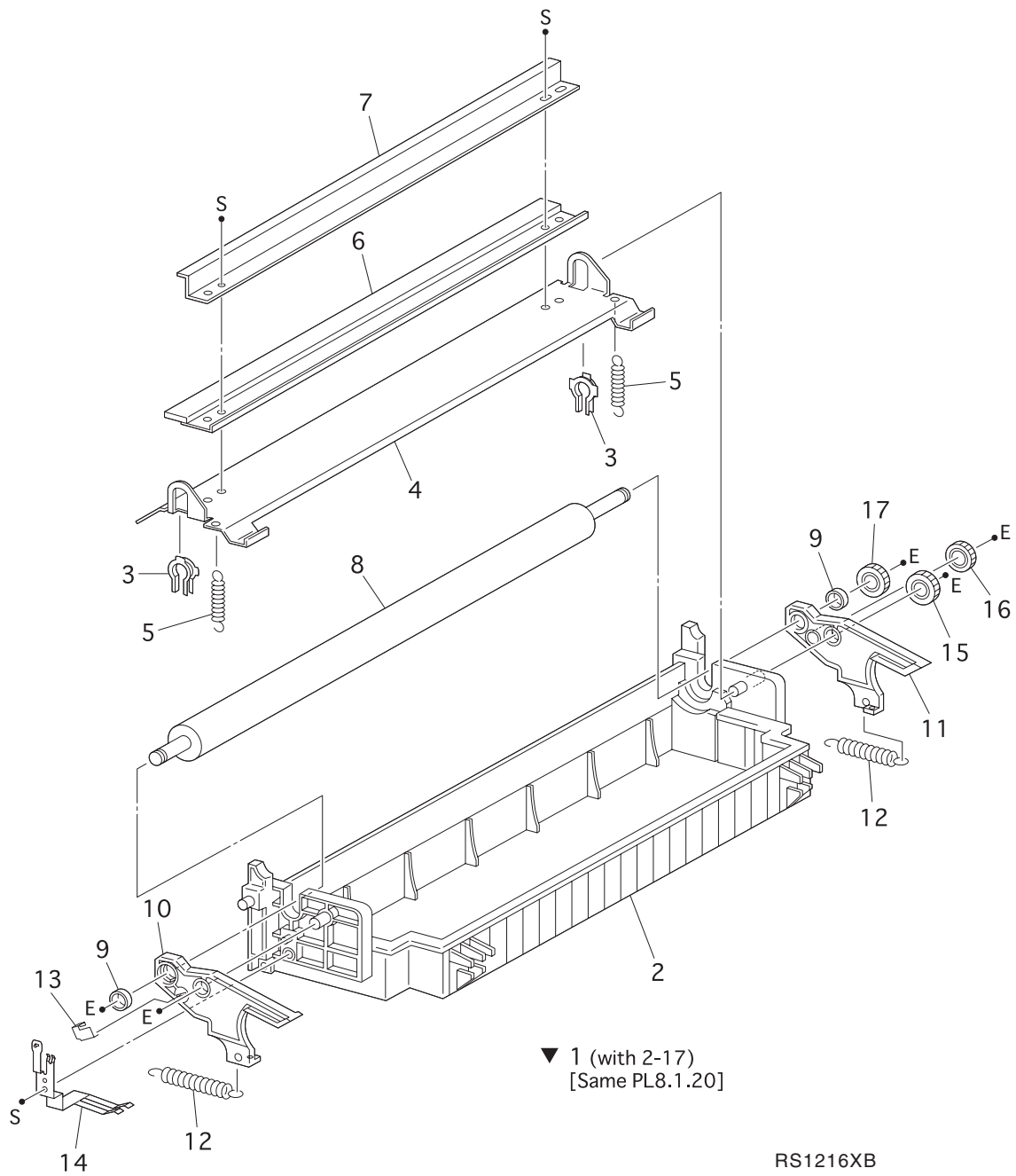

**PL8.4 IBT IV**

1. 2ND BTR ASSEMBLY (with 2~17) (same as PL8.1.20) (mandatory replacement part)P/N 865600K68710
2. 2ND BTR SUB ASSEMBLY .....N/A
3. SUPPORT BEARING .....N/A
4. SUPPORT PLATE .....N/A
5. BTR CLN SPRING .....N/A
6. 2ND BTR CLEANER .....N/A
7. BTR CLN BRACKET .....N/A
8. 2ND BTR.....N/A
9. 2ND BTR BEARING .....N/A
10. 2ND BTR FRONT ARM .....N/A
11. 2ND BTR REAR ARM .....N/A
12. 2ND BTR SPRING .....N/A
13. BTR EARTH PLATE-1 .....N/A
14. BTR EARTH PLATE-2 .....N/A
15. 2ND BTR GEAR A3 .....N/A
16. 2ND BTR GEAR A2 .....N/A
17. 2ND BTR GEAR A1 .....N/A

### PL9.1 Fusing 1

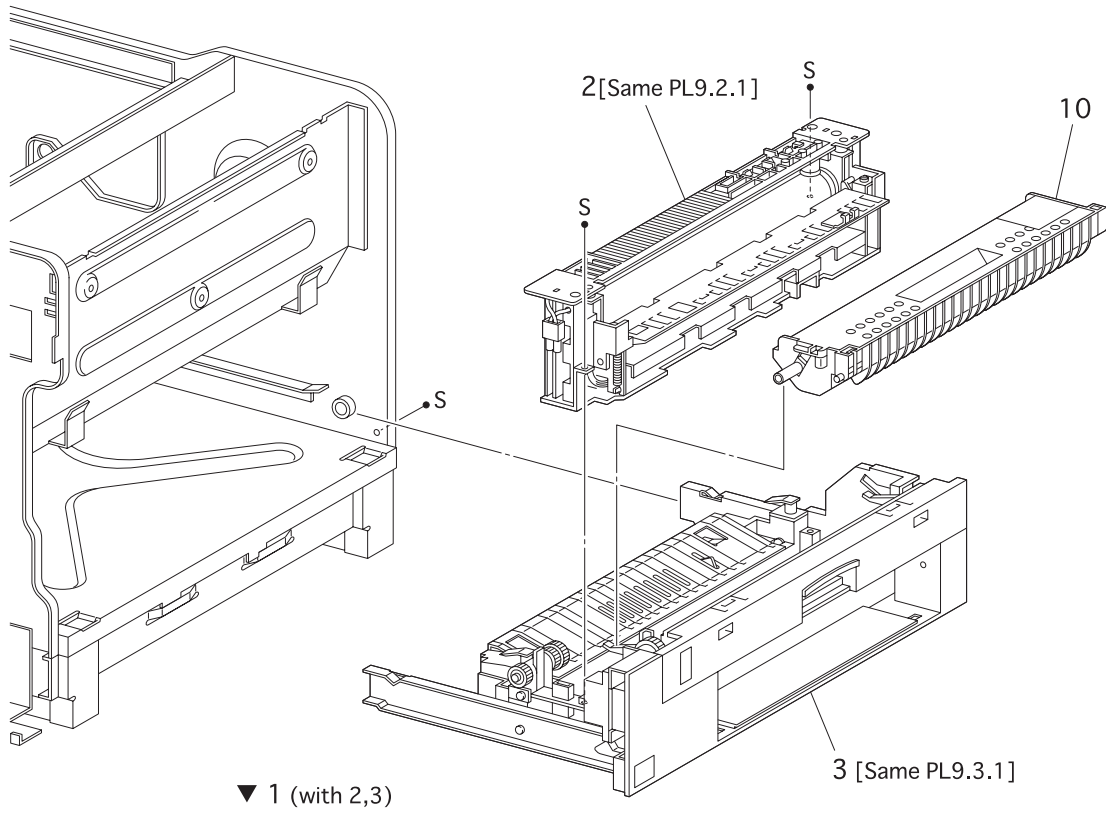

RS1217XB



**PL9.1 Fusing 1**

- 1. FUSER ASSEMBLY (with 2 and 3) .....N/A
- 2. MAIN FUSER ASSEMBLY-110V (same as PL 9.2.1) (mandatory replacement part) P/N 865600K69992
- 2. MAIN FUSER ASSEMBLY-220V (same as PL 9.2.1) (mandatory replacement part)P/N 865600K70012
- 3. FUSER TRAY ASSEMBLY (same as PL 9.3.1) .....N/A
- 10. OIL ROLL ASSEMBLY .....P/N 1710325-001
- 10. OIL ROLL ASSEMBLY (HI-DUTY).....P/N 1710325-002

### PL9.2 Fusing II

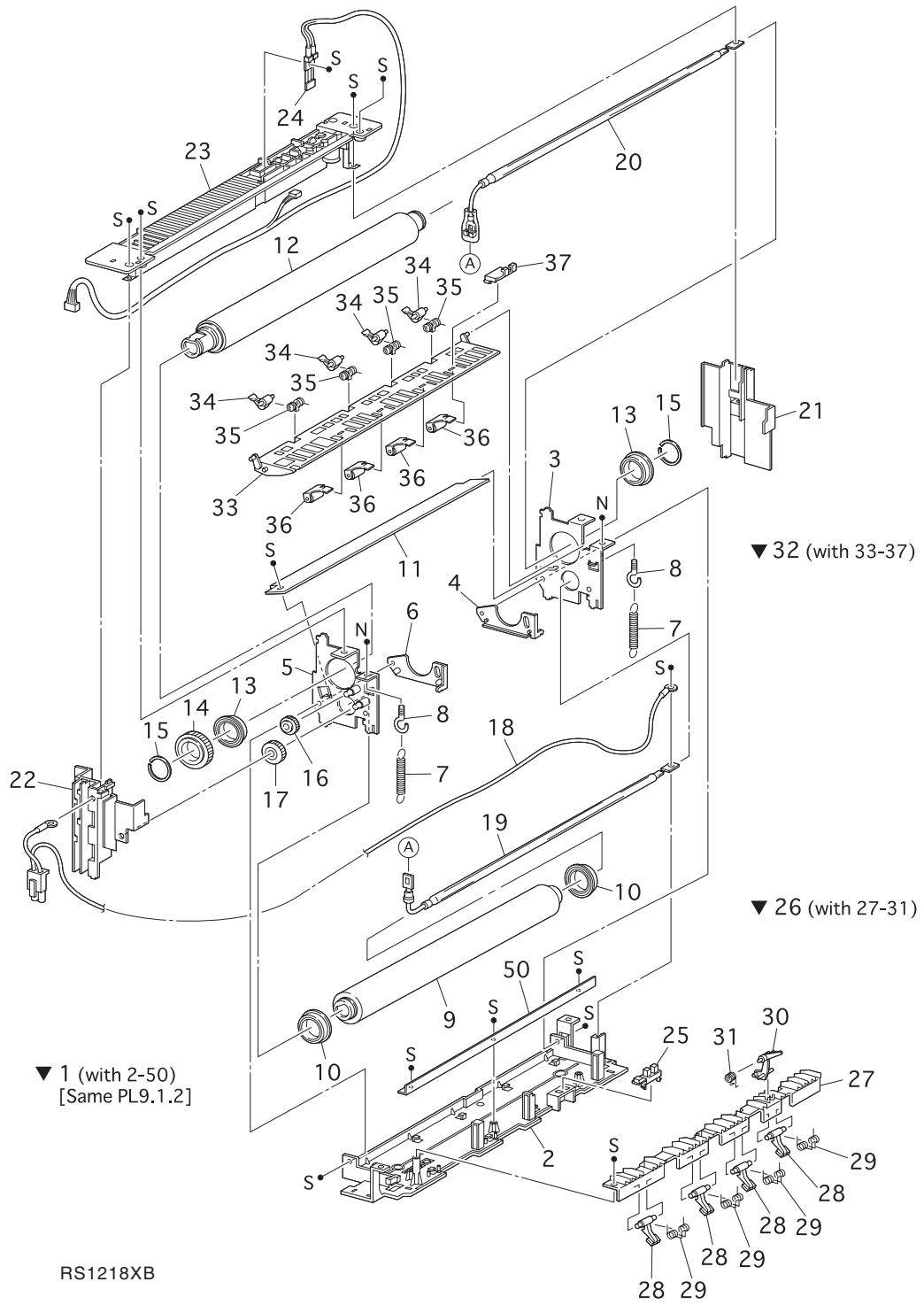

**PL9.2 Fusing II**

1. MAIN FUSER -110V (with 2~50) (same as PL 9.1.2) (mandatory replacement part)P/N 865600K69991	
1. MAIN FUSER -220V (with 2~50) (same as PL 9.1.2) (mandatory replacement part)P/N 865600K70011	
2. FUSER BOTTOM PLATE .....	N/A
3. FUSER FRONT FRAME .....	N/A
4. FUSER FRONT BRACKET .....	N/A
5. FUSER REAR FRAME .....	N/A
6. FUSER REAR BRACKET .....	N/A
7. NIP SPRING.....	N/A
8. NIP SCREW .....	N/A
9. PRESSURE ROLL .....	N/A
10. P/R BEARING .....	N/A
11. FUSER INLET PLATE .....	N/A
12. HEAT ROLL.....	N/A
13. H/R BEARING .....	N/A
14. H/R GEAR.....	N/A
15. H/R RING.....	N/A
16. H/R IDLER GEAR1 .....	N/A
17. H/R IDLER GEAR .....	N/A
18. HEATER WIRE.....	N/A
19. P/R HEATER .....	N/A
20. H/R HEATER .....	N/A
21. FUSER FRONT COVER .....	N/A
22. FUSER REAR COVER.....	N/A
23. FUSER UPPER ASSEMBLY .....	N/A
24. TEMPERATURE SENSOR ASSEMBLY .....	N/A
25. FUSER EXIT SENSOR .....	N/A
26. LOWER GUIDE ASSEMBLY (with 27~31).....	N/A
27. EXIT LOWER GUIDE.....	N/A
28. P/R FINGER.....	N/A
29. P/R FINGER SPRING.....	N/A
30. FUSER EXIT ACTUATOR .....	N/A
31. FUSER EXIT SPRING .....	N/A
32. UPPER GUIDE ASSEMBLY (with 33~37).....	N/A
33. EXIT UPPER GUIDE .....	N/A
34. H/R FINGER .....	N/A
35. H/R FINGER SPRING .....	N/A
36. EXIT-1 PINCH ASSEMBLY .....	N/A
37. EXIT UPPER LEVER.....	N/A
50. FUSER TIE PLATE.....	N/A

**PL9.3 Fusing III**

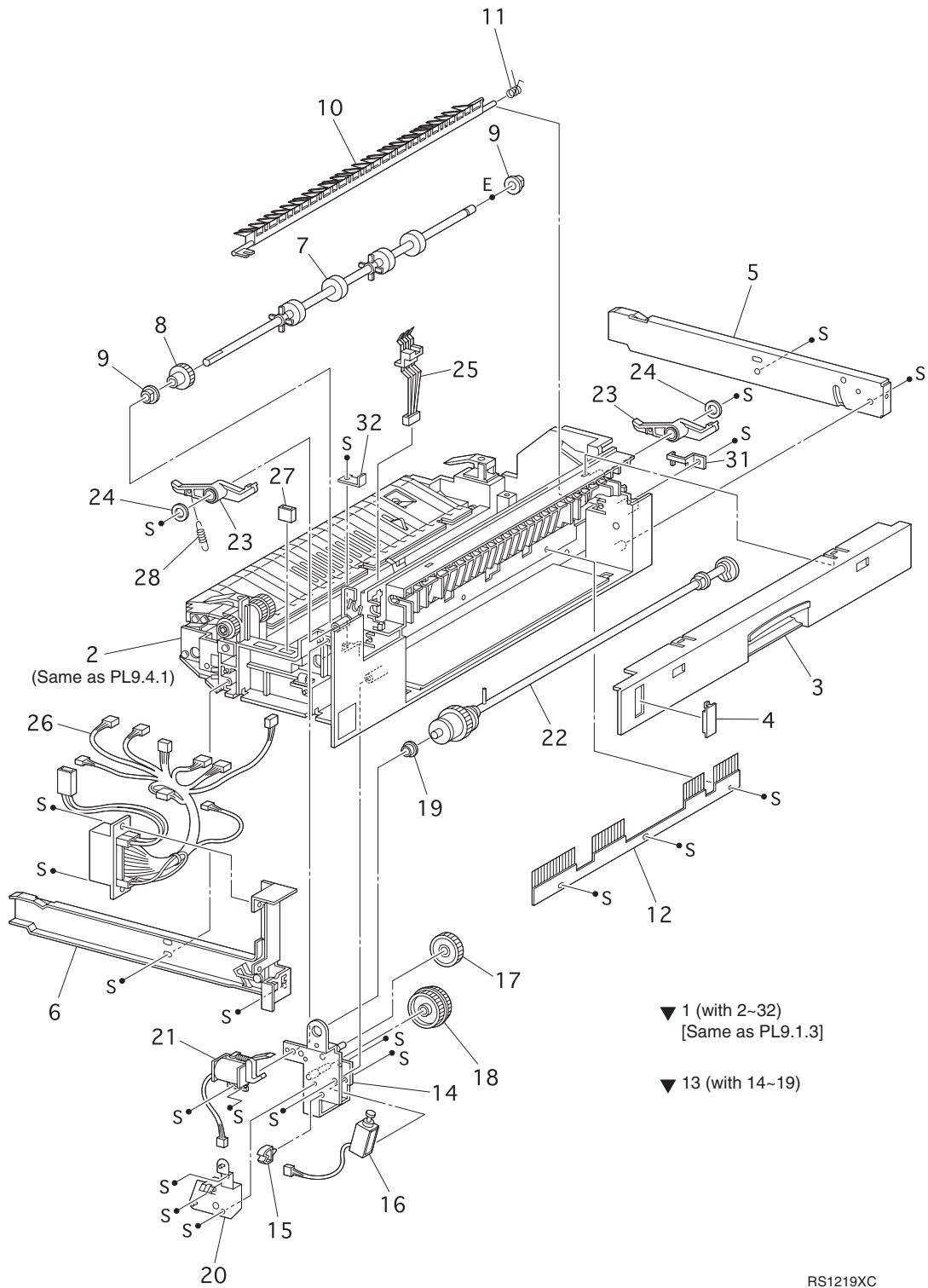

RS1219XC

**PL9.3 Fusing III**

1. FUSER TRAY ASSEMBLY (with 2~32) (same as PL 9.1.3).....	N/A	<b>865050K36380</b>
2. FUSER TRAY SUB ASSEMBLY (same as PL 9.4.1).....	N/A	
3. FUSER TRAY LEVER .....	P/N	865011E08180
4. FUSER TRAY CAP-B.....	N/A	
5. FUSER FRONT RAIL .....	N/A	
6. FUSER REAR RAIL.....	N/A	
7. EXIT-1 ROLL ASSEMBLY .....	N/A	
8. EXIT-1 GEAR.....	N/A	
9. EXIT-1 BEARING .....	N/A	
10. EXCHANGE CHUTE .....	N/A	
11. EXCHANGE SPRING .....	N/A	
12. F/U EXIT ELIMINATOR.....	N/A	
13. SOLENOID ASSEMBLY (with 14~19) .....	N/A	
14. EXCHANGE BRACKET.....	N/A	
15. MINI CLAMP-1 .....	N/A	
16. EXCHANGE SOLENOID .....	N/A	
17. IDLER GEAR FT1 .....	N/A	
18. IDLER GEAR FT2 .....	N/A	
19. OIL CAM BEARING.....	N/A	
20. FUSER EARTH-B.....	N/A	
21. OIL CAM SOLENOID.....	N/A	
22. OIL CAM ASSEMBLY.....	N/A	
23. OIL LINK .....	N/A	
24. LINK WASHER .....	N/A	
25. CRU SWITCH ASSEMBLY .....	N/A	
26. FUSER HARNESS ASSEMBLY .....	N/A	
27. CONNECTOR-5PW.....	N/A	
28. OIL LINK SPRING.....	N/A	
31. EXCHANGE STOPPER-F.....	N/A	
32. EXCHANGE STOPPER-R .....	N/A	

### PL9.4 Fusing IV

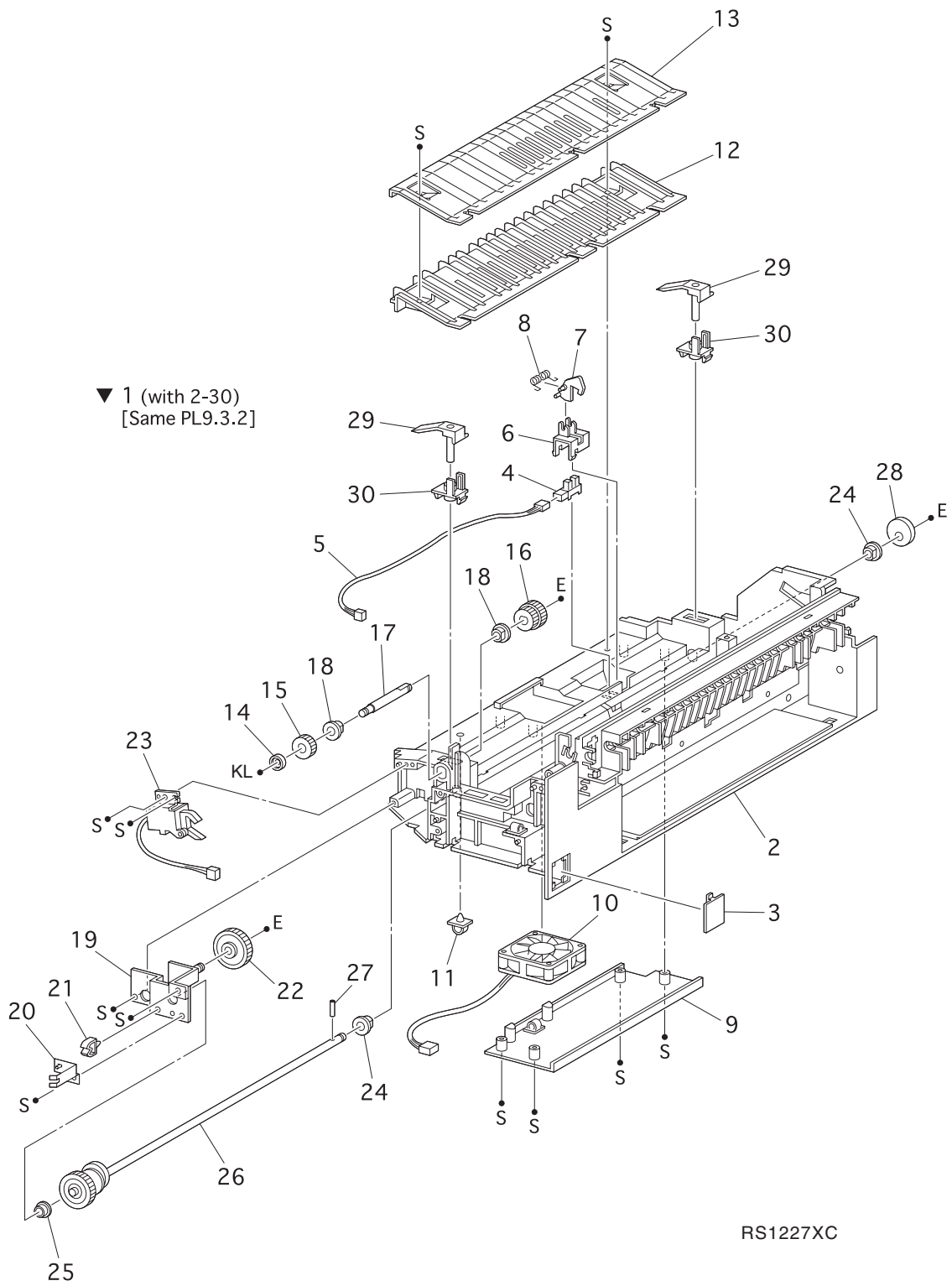

**PL9.4 Fusing IV**

1. FUSER TRAY SUB ASSEMBLY (with 2~30) (same as PL 9.3.2) ..	N/A
2. FUSER TRAY .....	N/A
3. FUSER TRAY CAP-A .....	N/A
4. FUSER IN SENSOR .....	N/A
5. FUSER IN HARNESS .....	N/A
6. FUSER IN HOLDER .....	N/A
7. FUSER IN ACTUATOR .....	N/A
8. FUSER IN SPRING .....	N/A
9. FUSER BOTTOM COVER .....	N/A
10. FUSER CHUTE FAN .....	N/A
11. FUSER TRAY CLAMP .....	N/A
12. FUSER PAPER GUIDE .....	N/A
13. HORIZONTAL CHUTE .....	N/A
14. FUSER COLLAR .....	N/A
15. INPUT GEAR FT1 .....	N/A <a href="#">865007E46291</a>
16. INPUT GEAR FT2 .....	N/A <a href="#">865007E46281</a>
17. INPUT STUD .....	N/A
18. STUD BEARING FT .....	N/A
19. INPUT BRACKET FT .....	N/A
20. FUSER EARTH-A .....	N/A
21. MINI CLAMP-2 .....	N/A
22. CLEANER CAM GEAR .....	N/A
23. CLEANER CAM SOLENOID .....	N/A
24. CLEANER CAM BEARING-F .....	N/A
25. CLEANER CAM BEARING-R .....	N/A
26. CLEANER CAM ASSEMBLY .....	N/A
27. CLEANER CAM PIN .....	N/A
28. CLEANER CAM .....	N/A
29. CLEANER CAM GUIDE .....	N/A
30. CLEANER CAM GUIDE HOLDER .....	N/A

### PL10.1 Paper Exit I

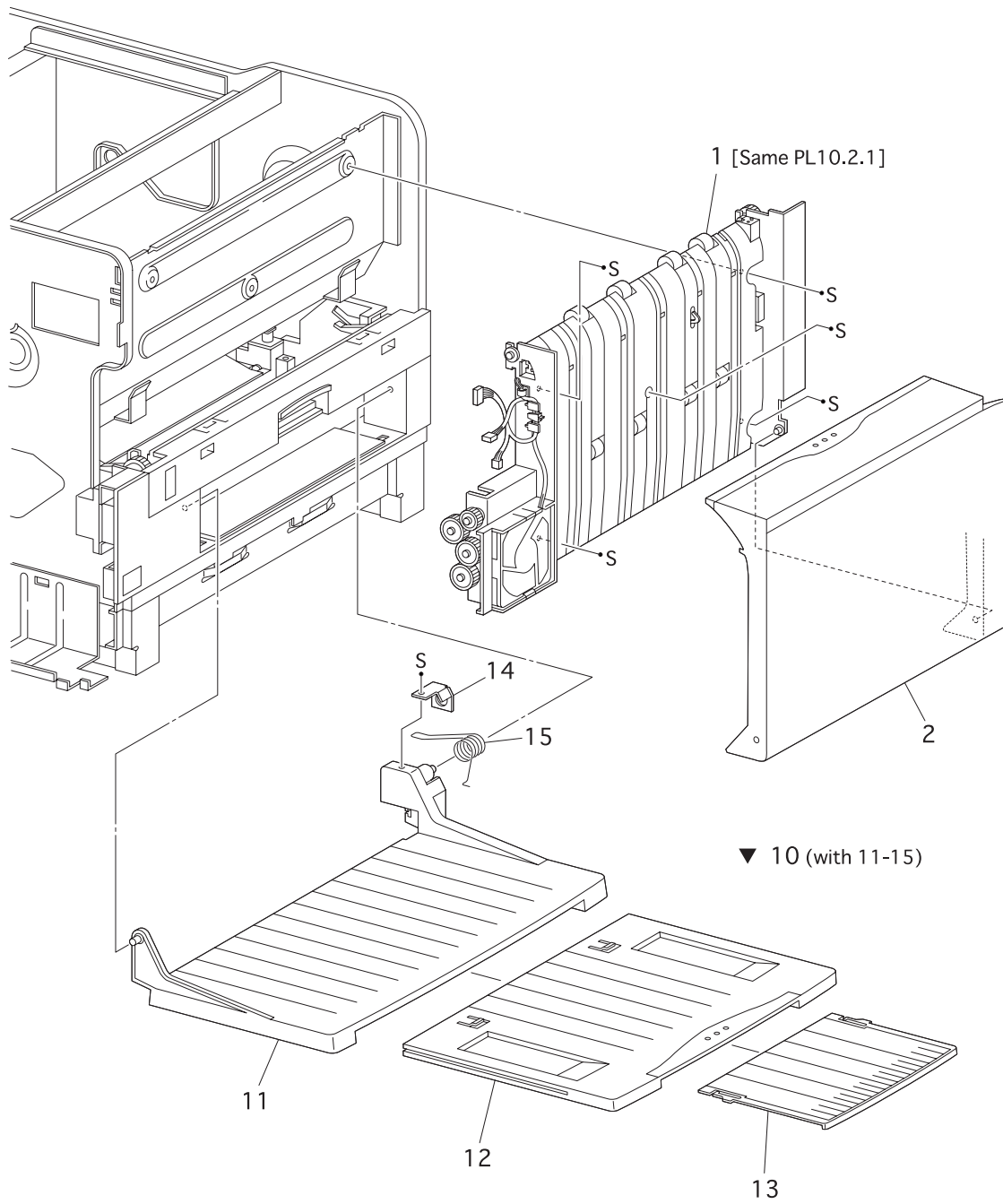

RS1220XB



**PL10.1 Paper Exit 1**

1. EXIT LOWER ASSEMBLY (same as PL10.2.1) .....	P/N 865054K11621
2. EXIT UPPER ASSEMBLY .....	P/N 865054K06621
10. EXIT TRAY ASSEMBLY (with 11~15) .....	P/N 865050K27592
11. EXIT TRAY1 .....	N/A
12. EXIT TRAY2 .....	N/A
13. EXIT TRAY3 .....	N/A
14. TRAY BRACKET .....	N/A
15. TRAY SPRING .....	N/A

**PL10.2 Paper Exit II**

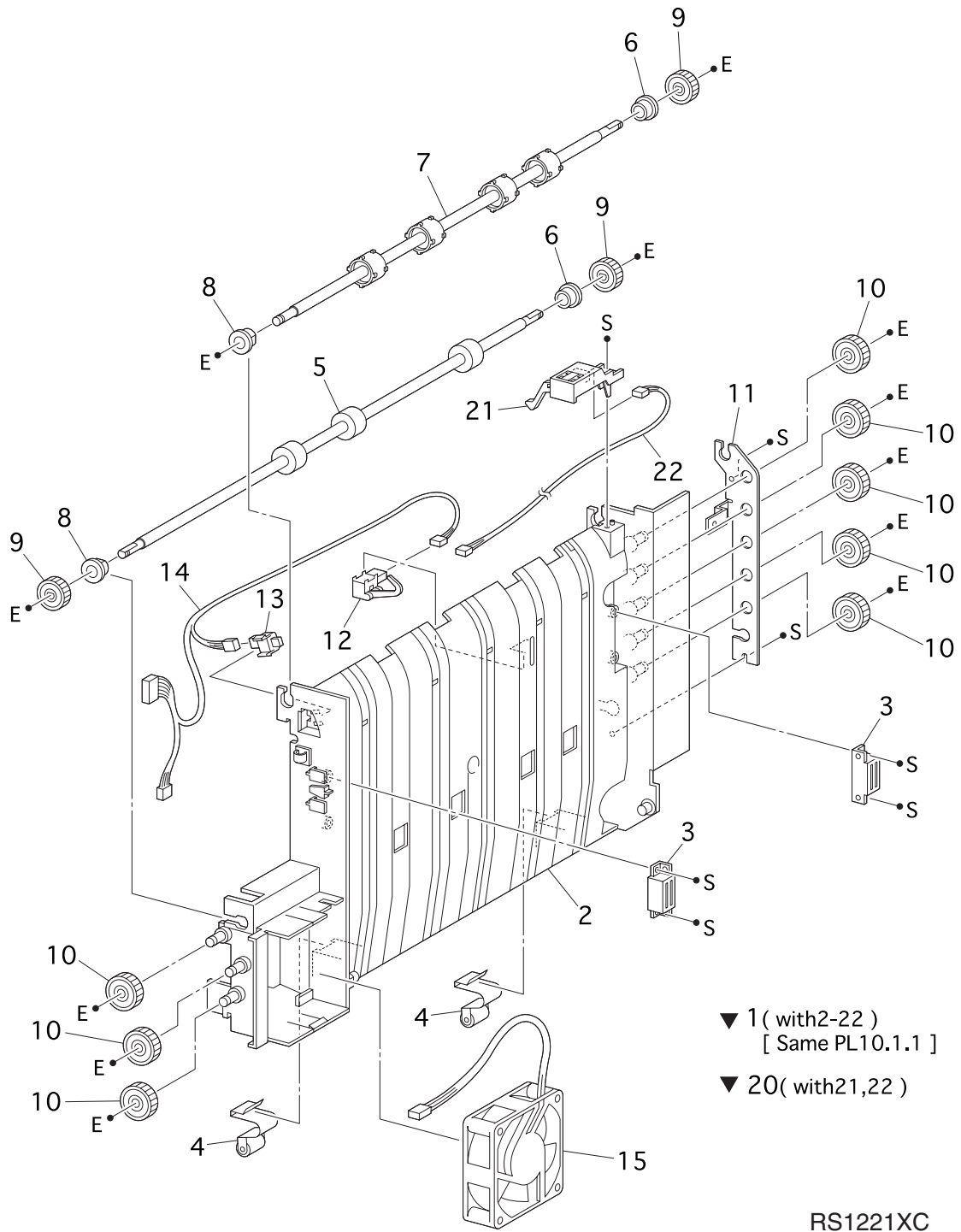

**PL10.2 Paper Exit II**

1. EXIT LOWER ASSEMBLY (with 2~22) (same as PL 10.1.1) .....	P/N 865054K11621
2. EXIT LOWER CHUTE.....	N/A
3. CATCH MAGNET .....	N/A
4. FUSER PINCH ASSEMBLY .....	N/A
5. EXIT-2 ROLL ASSEMBLY .....	P/N 865600K68750
6. EXIT FRONT BEARING .....	N/A
7. EXIT-3 ROLL ASSEMBLY .....	N/A
8. EXIT REAR BEARING.....	N/A
9. SPUR GEAR .....	N/A
10. EXIT IDLER GEAR.....	N/A
11. EXIT CHUTE PLATE.....	N/A
12. TOP EXIT SENSOR .....	P/N 865130E82730
13. EXIT CHUTE SWITCH.....	P/N 865100E93440
14. EXIT HARNESS.....	N/A
15. FUSER FAN .....	P/N 865127E81311
20. FULL SENSOR ASSEMBLY (with 21 and 22) .....	P/N 865130K55990
21. FULL STACK SENSOR .....	N/A
22. FULL STACK HARNESS .....	N/A

### PL11.1 Drive

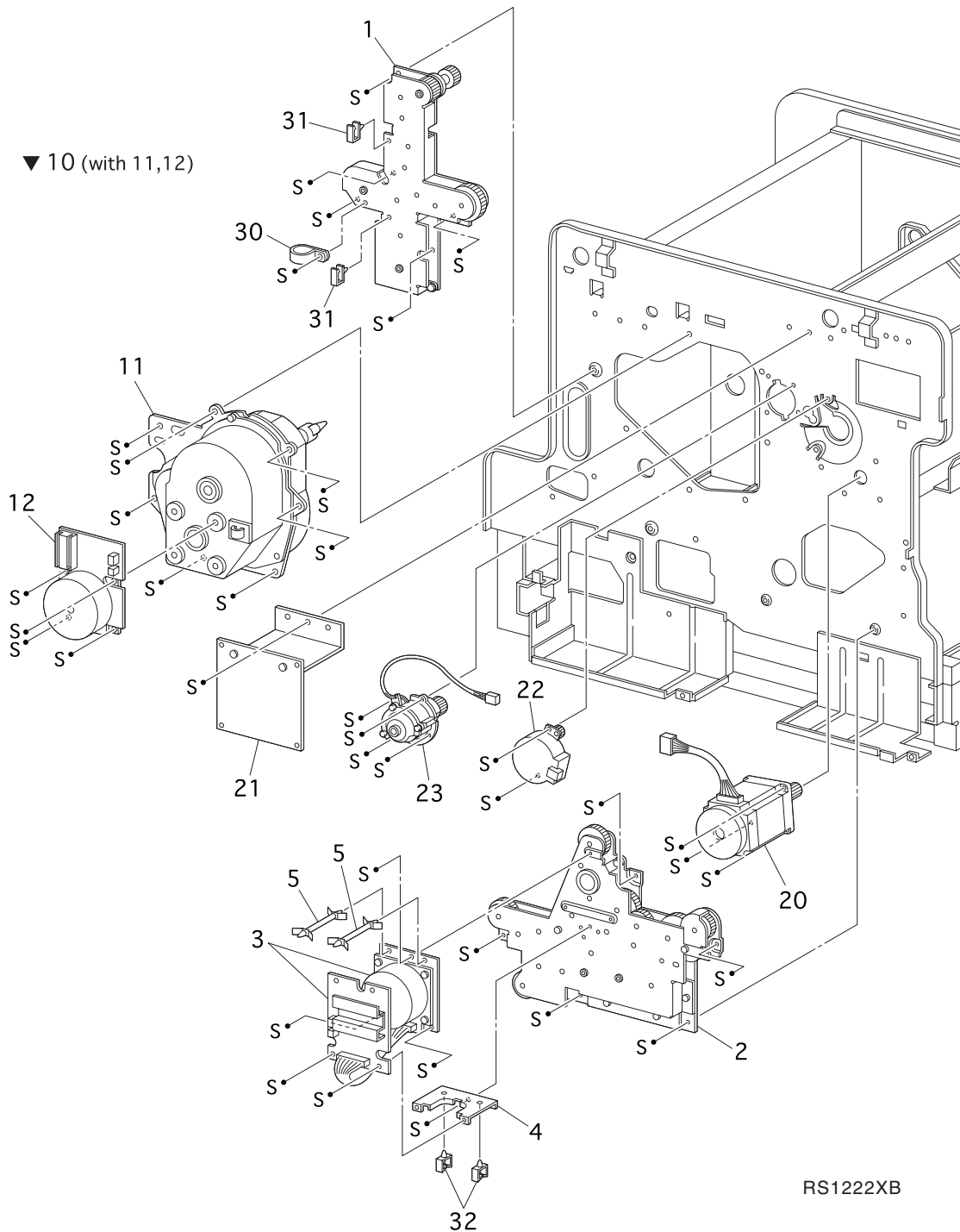

RS1222XB

**PL11.1 Drive**

1. P/H DRIVE ASSEMBLY .....	P/N 865007K84580
2. FUSER DRIVE ASSEMBLY .....	P/N 865007K83603
3. P/H MOTOR ASSEMBLY .....	P/N 865600K68650
4. P/H MOTOR BRACKET .....	N/A
5. P/H MOTOR SUPPORT .....	N/A
10. PROCESS DRIVE ASSEMBLY (with 11 and 12) .....	P/N 865127K24661
11. PROCESS WDD ASSEMBLY .....	N/A
12. PROCESS MOTOR ASSEMBLY .....	N/A
20. ROTARY MOTOR ASSEMBLY .....	P/N 865127K21171
21. ROTARY MOTOR PWB .....	P/N 865160K38740
22. DISPENSE MOTOR ASSEMBLY .....	P/N 865127K16311
23. DEVELOPER CLUTCH ASSEMBLY .....	P/N 865121K87716
30. DRIVE CLAMP-N .....	N/A
31. DRIVE CLAMP-Y .....	N/A
32. DRIVE CLAMP-W .....	N/A

### PL12.1 Frame

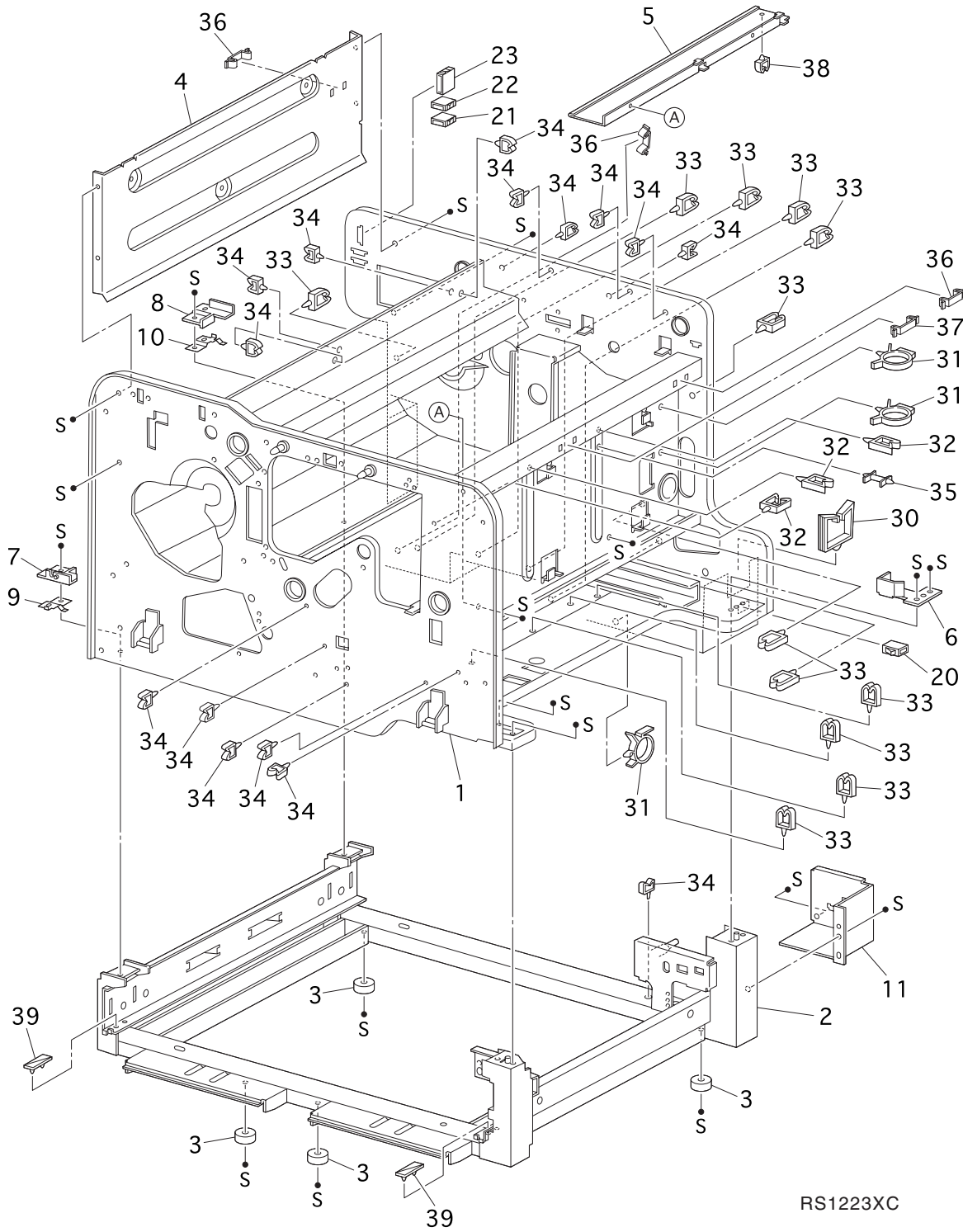

RS1223XC

**PL12.1 Frame**

1. BASE FRAME ASSEMBLY .....	N/A
2. FEEDER FRAME ASSEMBLY .....	N/A
3. FRAME FOOT .....	N/A
4. DEVELOPER TIE PLATE.....	N/A
5. CATCH PLATE .....	N/A
6. P/H GUIDE BRACKET .....	N/A
7. FUSER FRONT GUIDE .....	N/A
8. FUSER REAR GUIDE.....	N/A
9. FUSER FRONT SPRING .....	N/A
10. FUSER REAR SPRING .....	N/A
20. FEEDER CONNECTOR-2P .....	N/A
21. EXIT CONNECTOR-3P .....	P/N 865913W01205
22. EXIT CONNECTOR-4P .....	P/N 865913W01227
23. EXIT CONNECTOR-8P .....	P/N 865913W01210
30. EDGE SADDLE-U.....	N/A
31. FRAME CLAMP-R.....	N/A
32. FRAME CLAMP-L .....	N/A
33. FRAME CLAMP-M.....	N/A
34. FRAME CLAMP-S .....	N/A
35. PWB SUPPORT .....	N/A
36. FRAME CLAMP-PS .....	N/A
37. FRAME CLAMP-PL.....	N/A
38. FRAME CLAMP-U .....	N/A
39. SHEET CLAMP .....	P/N 865019E345000

### PL13.1 Electrical I

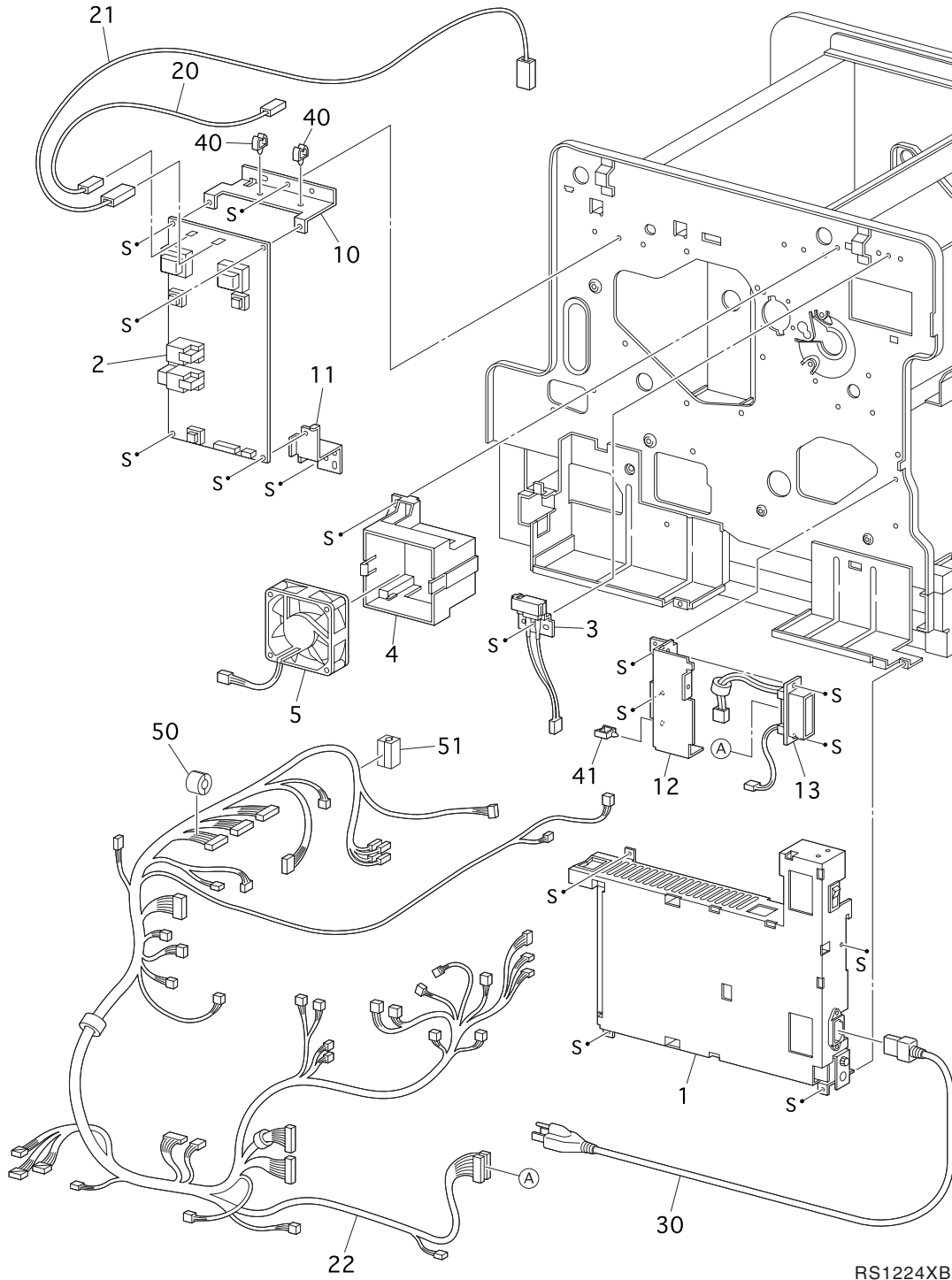

RS1224XB



**PL13.1 Electrical I**

1. LVPS-110V .....	P/N 865105K14351
1. LVPS-220V .....	P/N 865105K94971
2. HVPS .....	P/N 865105K11871
3. TOP COVER SWITCH.....	P/N 865110K98810
4. FAN DUCT.....	N/A
5. DEVELOPER FAN .....	P/N 865127E81301
10. HVPS BRACKET-1 .....	N/A
11. HVPS BRACKET-2 .....	N/A
12. CONNECTOR BRACKET-F.....	N/A
13. FUSER CONNECTOR .....	P/N 865162K25462
20. BCR WIRE .....	N/A
21. DEVELOPER WIRE.....	N/A
22. MAIN HARNESS ASSEMBLY .....	P/N 865162K16124
30. POWER CORD .....	N/A
40. ELECTRIC CLAMP-S.....	N/A
41. ELECTRIC CLAMP-M .....	N/A
50. FERRITE CORE-M1 .....	N/A
51. FERRITE CORE-M2 .....	N/A

PL13.2 Electrical II

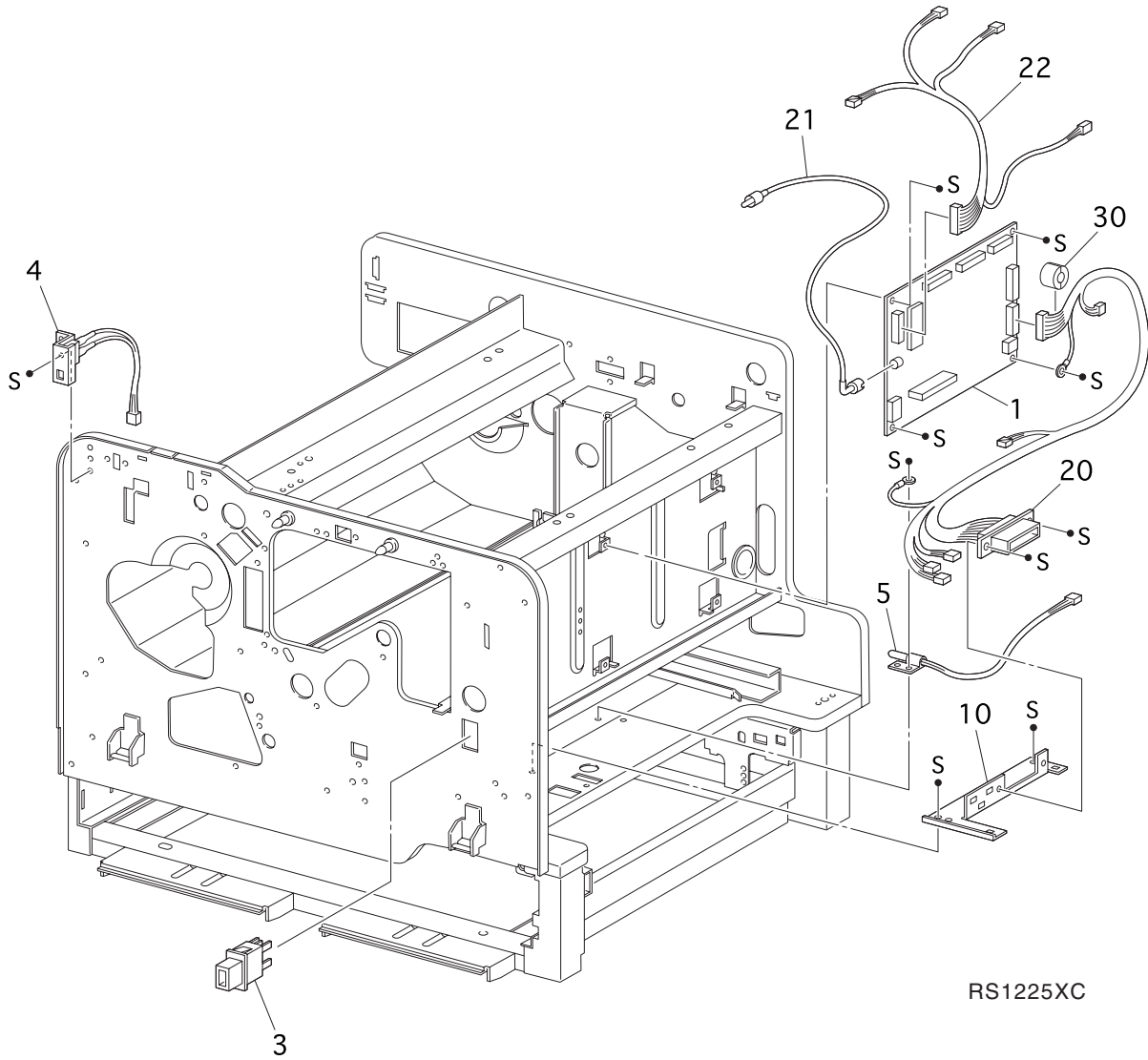

**PL13.2 Electrical II**

1. MCU PWB (with ROM).....	P/N 865160K52321
1. MCU PWB (no ROM).....	P/N 865160K59151
2. MCU ROM.....	P/N 865537K50872
3. FRONT COVER SWITCH R.....	P/N 865110K07831
4. FRONT COVER SWITCH L.....	P/N 865110K08280
5. ENVIRONMENT SENSOR.....	P/N 865130K87550
10. CONNECTOR BRACKET-P.....	N/A
20. P/H HARNESS ASSEMBLY.....	P/N 865162K16221
21. VIDEO HARNESS.....	P/N 865162K16421
22. ROS HARNESS.....	P/N 865162K16134
30. FERRITE CORE-P1.....	N/A

### PL14.1 Controller

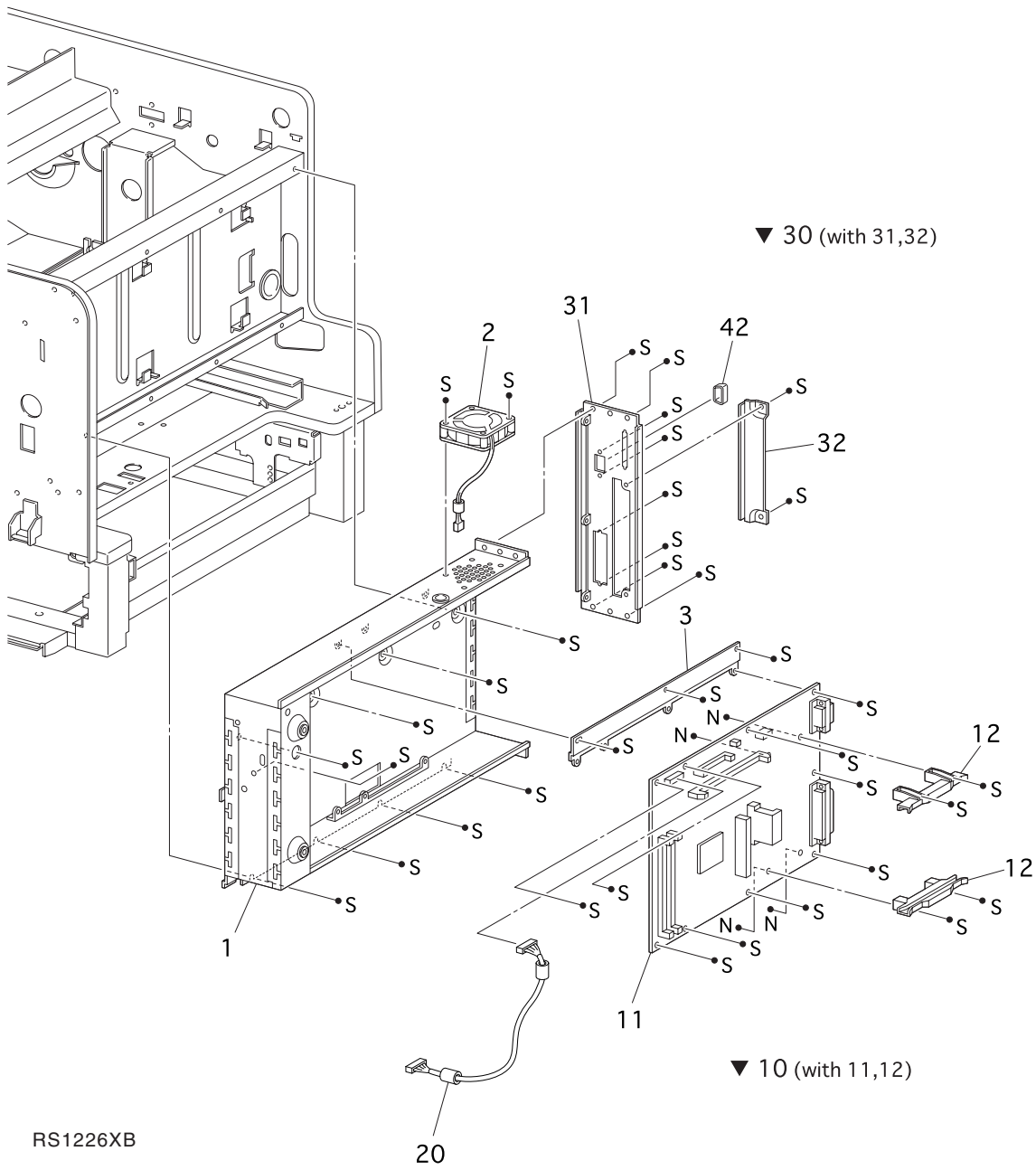

**PL14.1 Controller**

1. CONTROLLER CHASSIS ASSEMBLY .....	N/A
2. CONTROLLER FAN .....	P/N 865127K23170
3. CONTROLLER PLATE.....	N/A
10. MINOLTA-QMS CONTROLLER EX PWB (with 11 and 12).....	P/N 2293268-902F
10. MINOLTA-QMS CONTROLLER CX PWB (with 11 and 12) .....	P/N 2293268-901H
11. CONTROLLER PWB-A.....	N/A
12. NIC HOLDER .....	N/A
20. PANEL HARNESS.....	P/N 865162K42090
30. CONTROLLER PLATE ASSEMBLY (with 31 and 32) .....	N/A
31. CONTROLLER PLATE.....	N/A
32. OPTION PLATE.....	N/A
42. EP-SV CAP .....	N/A

### PL30.1 Option Tray I

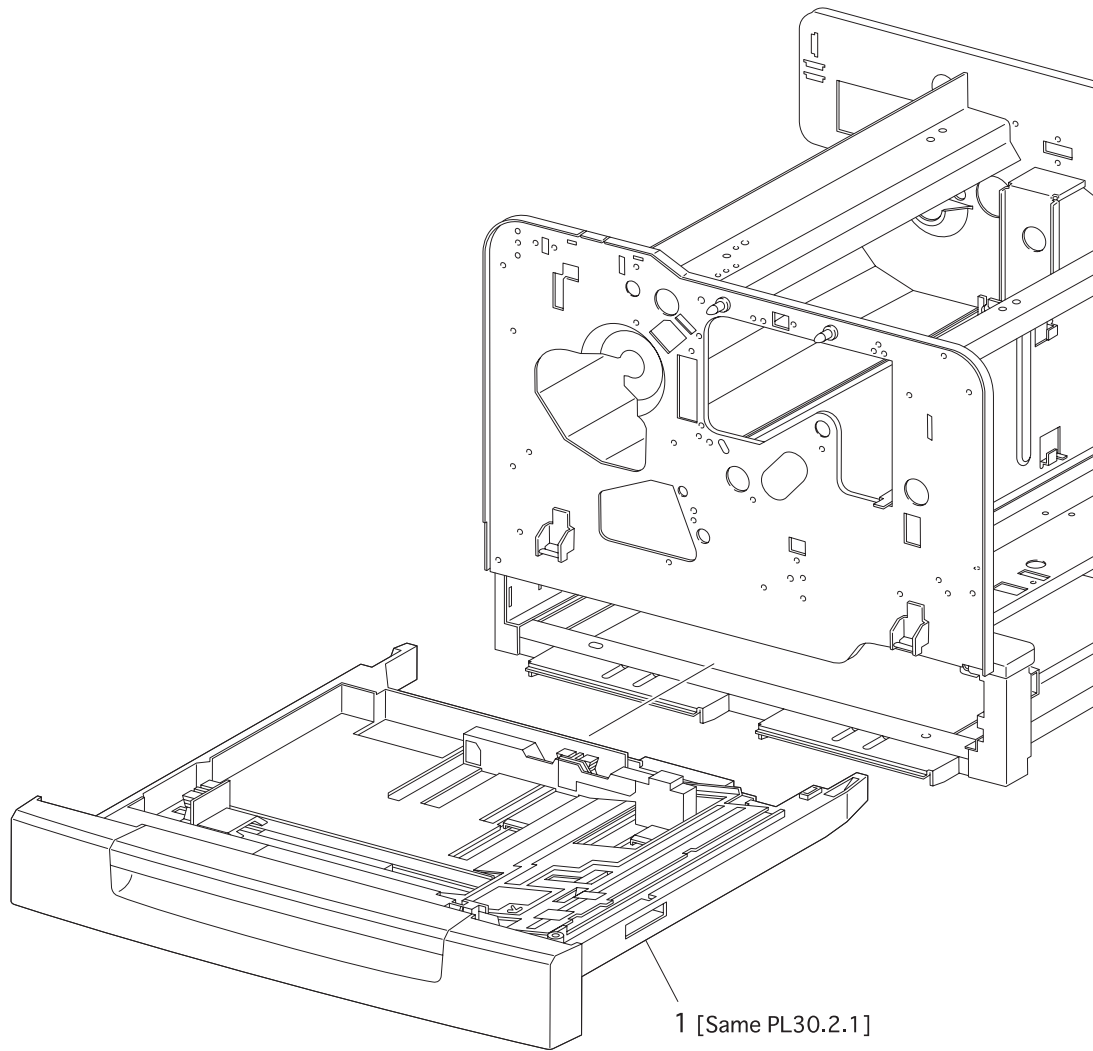

RS1228XB

**PL30.1 Option Tray I**

1. OVERSIZE TRAY [same as PL30.2.1].....P/N 1710318-001

### PL30.2 Option Tray II

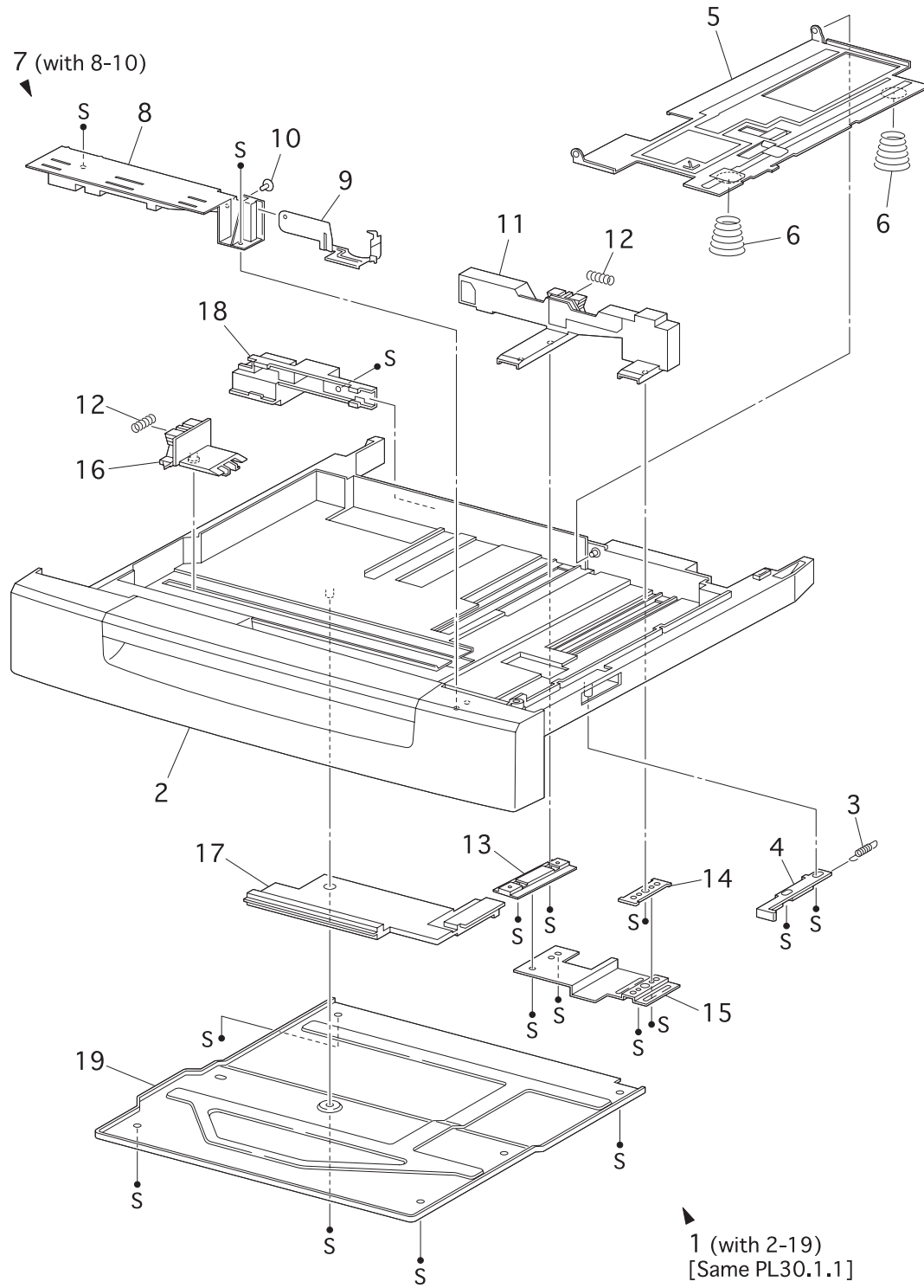

RS1229XB



**PL30.2 Option Tray II**

1. OVERSIZE TRAY (with 2~19) [same as PL30.1.1].....	P/N 1710318-001
2. OPTION TRAY HOUSING .....	N/A
3. PLATE LINK SPRING.....	N/A
4. PLATE LINK.....	N/A
5. BOTTOM PLATE ASSEMBLY.....	N/A
6. TRAY N/F SPRING .....	N/A
7. FRONT GUIDE ASSEMBLY (with 8~10).....	N/A
8. FRONT GUIDE.....	N/A
9. FRONT SNUBBER.....	N/A
10. SNUBBER STOPPER.....	N/A
11. REAR GUIDE ASSEMBLY .....	N/A
12. GUIDE SPRING.....	N/A
13. REAR GUIDE PLATE L.....	N/A
14. REAR GUIDE PLATE R.....	N/A
15. LOCK PLATE .....	N/A
16. END GUIDE.....	N/A
17. GUIDE STOPPER.....	N/A
18. OVERSIZE ACTUATOR.....	N/A
19. TRAY BOTTOM COVER .....	N/A

Blank Page







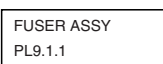
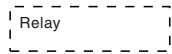

**Section 12 - Wiring Diagrams and Signal Information****Contents**

Wiring Diagram Notations .....	12-2
Master Wiring Diagram .....	12-3
BD1 MCU PWB↔LVPS & ROS Assembly↔Fuser Assembly↔Various Interlock Switches .....	12-4
BD2 MCU PWB↔ADC Sensor↔Erase Lamp↔Waste Toner Sensor↔CRUM.....	12-6
BD3 LVPS & MCU PWB↔HVPS↔Xerographic Components .....	12-8
BD4 MCU PWB↔Used Cartridge Sensor↔Cartridge Sensor↔Rotary Sensor↔Developer Clutch↔Developer Fan↔Dispense Motor.....	12-10
BD5 MCU PWB & LVPS↔Rotary Motor PWB↔Rotary Motor .....	12-12
BD6 MCU PWB↔BTR Cam Solenoid↔TR0 Sensor↔Paper Handling Motor Assembly↔Process Motor Assembly .....	12-14
BD7 MCU PWB↔LVPS↔Fuser Assembly↔Oil Roll Assembly .....	12-16
BD8 MCU PWB↔Fuser Tray Assembly↔Environment Sensor .....	12-18
BD9 MCU PWB↔Size Switch Assembly↔Feed Solenoid↔No Paper Sensor↔Low Paper Sensor .....	12-20
BD10 MCU PWB↔Main P/H Assembly .....	12-22
BD11 MCU PWB↔Main Paper Handling Assembly↔MSI Assembly .....	12-24
BD12 MCU PWB↔Top Exit Sensor↔Exit Chute Switch↔Full Stack Sensor↔Fuser Fan .....	12-26
BD13 MCU PWB↔Controller PWB↔Operation Panel↔Controller Fan .....	12-28

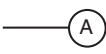
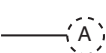
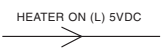
## Wiring Diagram Notations

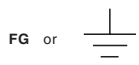
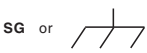
This section of the manual contains a Master Wiring Diagram for the Qms Magicolor 330 laser printer. The Master Wiring Diagram shows the interconnections of the major subsystems within the printer. The remainder of this section divides the Master Wiring Diagram into thirteen individual block diagrams (BD) to better illustrate the electrical relationships between components and assemblies within the printer. Each wire in the diagrams is tagged with a signal name and each wire is terminated at both ends with a pin number.

The wiring diagrams presented in this manual use the following circuit notations to describe components and signal paths within the printer.

	<p>Plug/Jack XX                  — is a male connector (plug) of P/J xx                  &gt; is a female connector (jack) of P/J xx</p>
	<p>Component name                  Section 14 Parts List location number</p>
	<p>Component or sub-assembly within a larger assembly</p>
	<p>Wire connection</p>
	<p>Frame ground wire fastened with a screw to the printer frame</p>
	<p>Diagram simplification; wire continues at another point within the same Block Diagram.</p>
	<p>Diagram simplification; wire continues at another point within a different Block Diagram.</p>
	<p>Wire with signal name and direction of signal flow.                  In some cases, such as a signal name of <b>5VDC</b>, the signal is a steady flow of approximately 5VDC.                  In other cases, such as a signal name <b>HEATER ON (L) 5VDC</b>, the signal is near 5VDC when off and near 0VDC when on. Or in the case of the signal name <b>HEATER ON (H) 5VDC</b>, the signal is near 5VDC when on and near 0VDC when off.</p>
	<p>Metallic contact, such as a spring, with direction of signal flow.</p>
	<p>Frame ground</p>
	<p>Signal ground</p>
	<p>Analog ground</p>
	<p>Signal return</p>
	<p>Diagram simplification; connector is continued on the indicated Block Diagrams</p>

RS1420XB

# Master Wiring Diagram

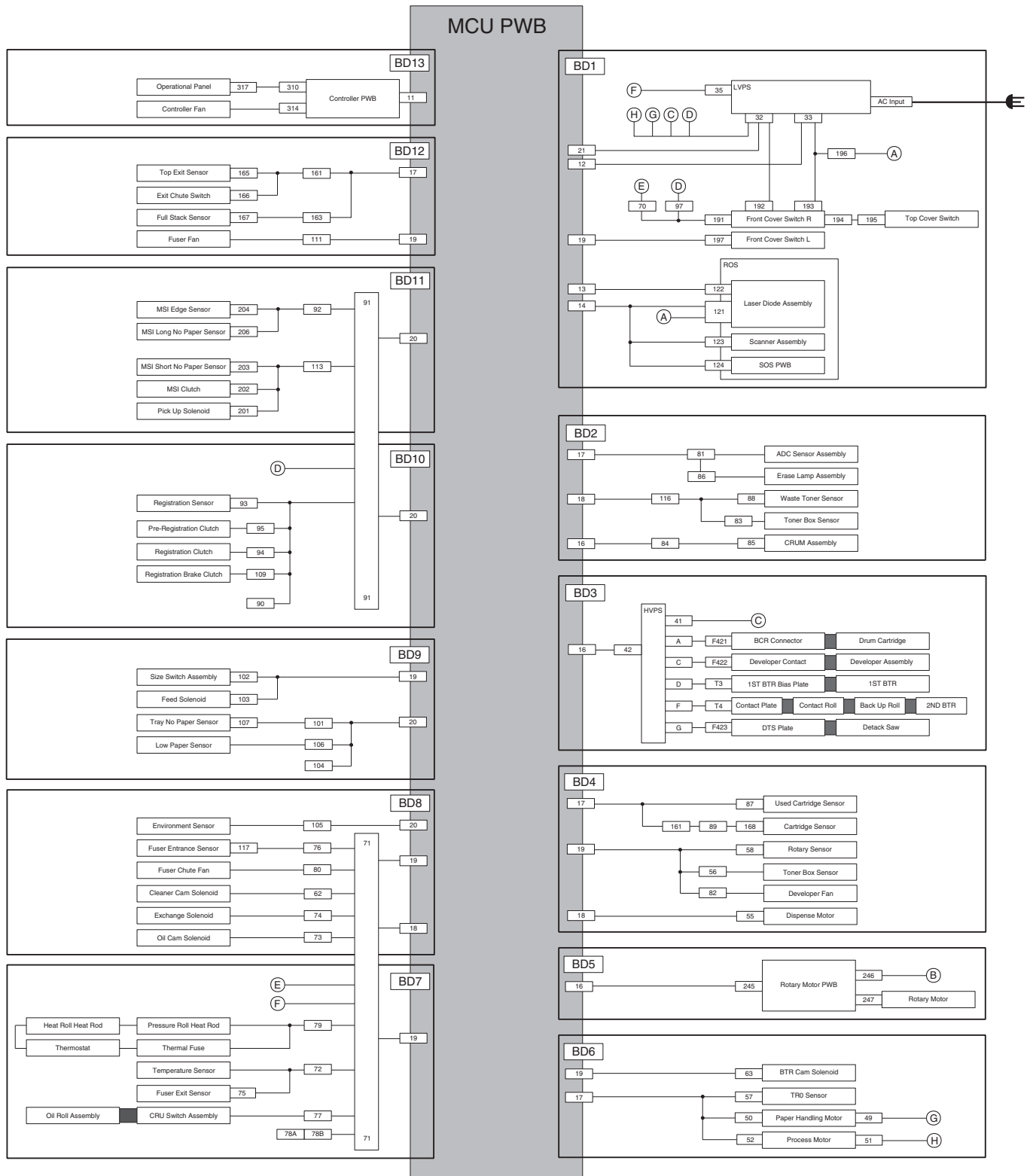

**BD1 MCU PWB↔LVPS & ROS Assembly↔Fuser Assembly↔Various Interlock Switches**

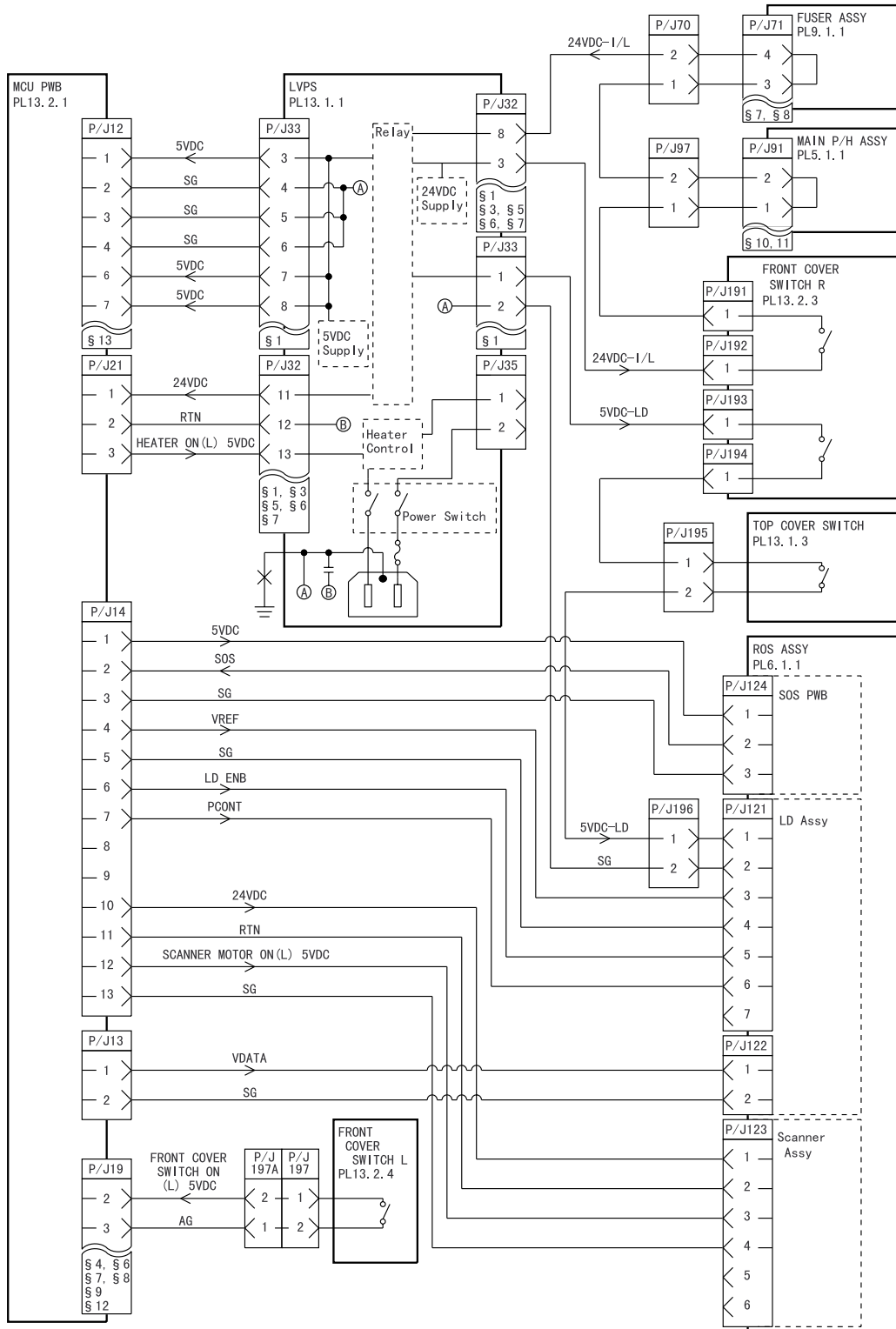

RS1401XB

**BD1 MCU PWB↔LVPS & ROS Assembly↔Fuser Assembly↔Various Interlock Switches**

The following table shows the signal names for this BD:

Signal Name	Description
HEATER ON (L) 5VDC	Switches Heat Rods. Low=On. High=Off
SOS	Start of Scan signal
VREF	Reference voltage for the Laser Diode
FRONT COVER SWITCH ON (L) 5VDC	Monitors state of the Front Cover Switch. Low=On. High=Off
LD ENB	Switches the Laser Diode. Low=Off. High=On
SCANNER MOTOR ON (L) 5VDC	Switches the Scanner Motor. Low=On. High=Off
VDATA	Video data signal to the Laser Diode. Low=Off. High=On
5VDC-LD	+5VDC to the Laser Diode

**BD2 MCU PWB ↔ ADC Sensor ↔ Erase Lamp ↔ Waste Toner Sensor ↔ CRUM**

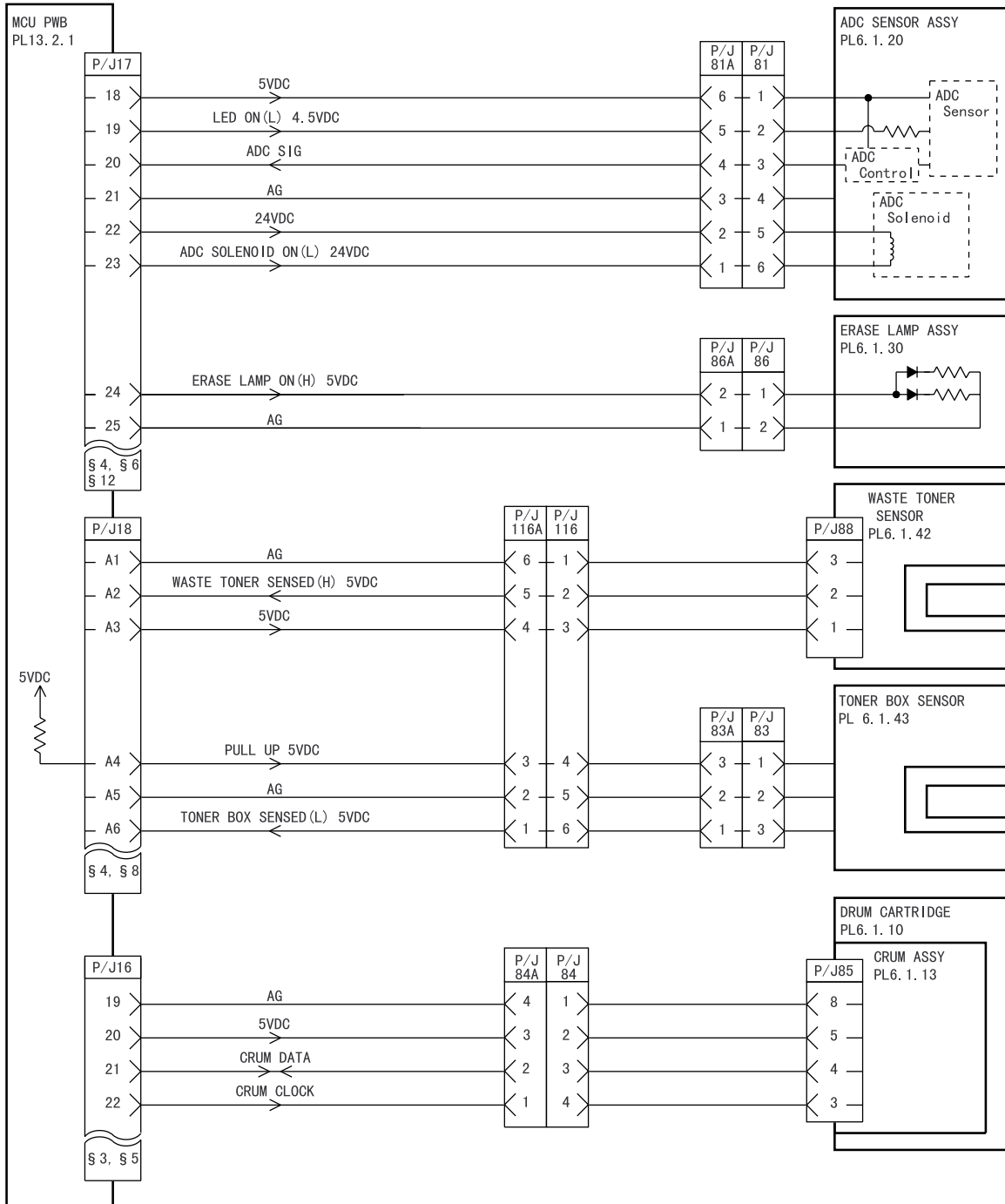

RS1402XC



**BD2 MCU PWB↔ADC Sensor↔Erase Lamp↔Waste Toner Sensor↔CRUM**

The following table shows the signal names for this BD:

Signal Name	Description
LED ON (L) 5VDC	Switches the ADC LED. Low=On. High=Off
ADC SIG	Analog signal from the ADC Sensor
ADC SOLENOID ON (L) 24VDC	Switches the ADC Cleaning Solenoid. Low=On. High=Off
ERASE LAMP ON (H) 5VDC	Switches the Erase Lamp. Low=Off. High=On
TONER BOX SENSED (L) 5 VDC	Monitors presence of Toner Box. Low=In place. High=Not in place
WASTE TONER SENSED (H) 5VDC	Monitors the level of toner in the Waste Toner Box. Low=Box not full. High=Box full
CRUM DATA	Xerographic Cartridge CRUM data signal
CRUM CLOCK	Xerographic Cartridge CRUM clock signal

**BD3 LVPS & MCU PWB ↔ HVPS ↔ Xerographic Components**

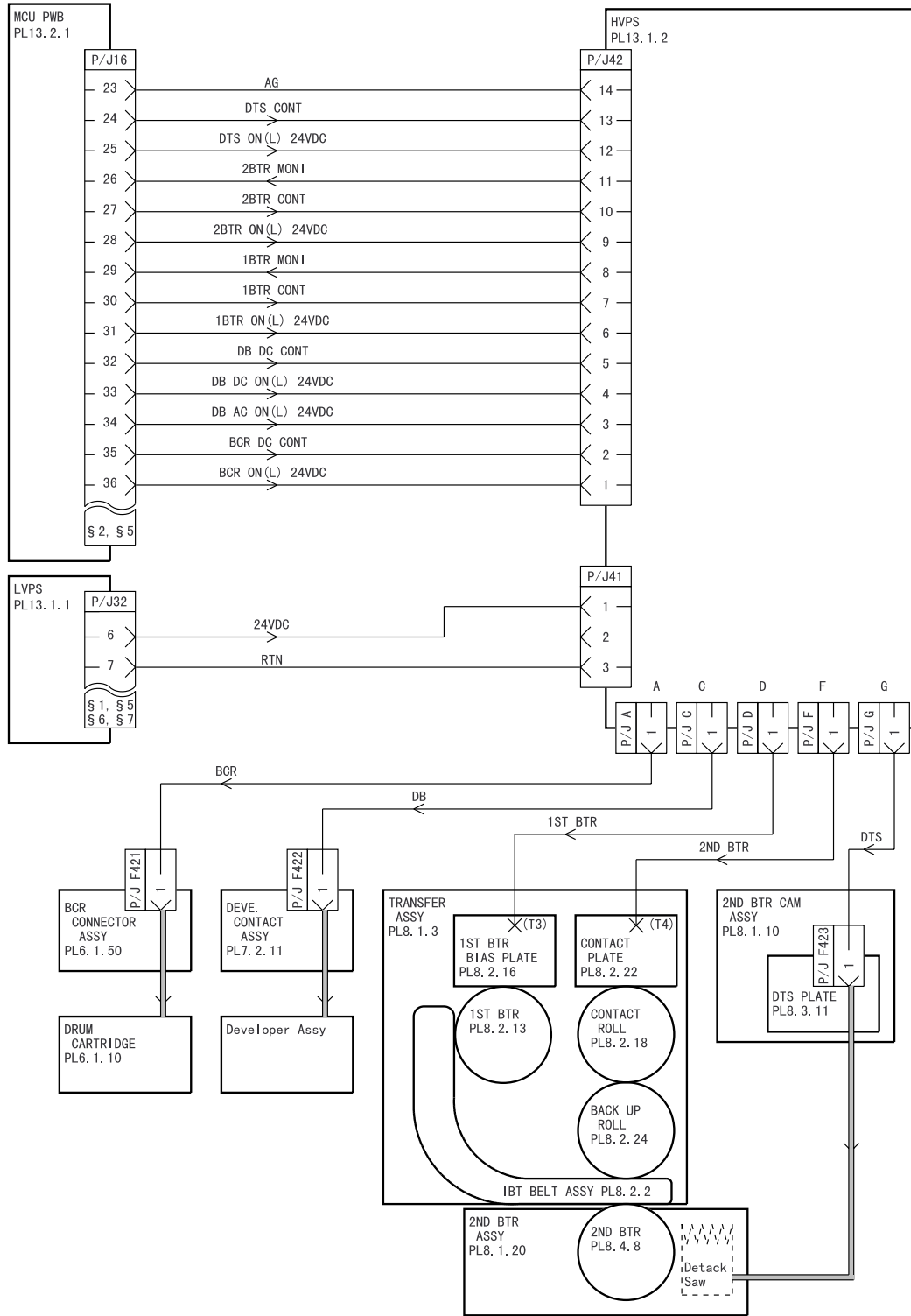

RS1403XB

RS1403XB

**BD3 LVPS & MCU PWB↔HVPS↔Xerographic Components**

The following table shows the signal names for this BD:

Signal Name	Description
DTS CONT	Analog control signal for the DTS
DTS ON (L) 24VDC	Switches the Detack Saw voltage
2BTR MONI	Analog signal that monitors the current in the 2nd Bias Transfer Roll
2BTR CONT	Analog control signal for the 2nd BTR
2BTR ON (L) 24VDC	Switches the 2nd Bias Transfer Roll voltage
1 BTR MONI	Analog signal that monitors the current in the 1st Bias Transfer Roll
1 BTR CONT	Analog control signal for the 1st BTR
1 BTR ON (L) 24VDC	Switches the 1st Bias Transfer Roll voltage
DB DC CONT	Analog control signal for the DC component of the Developer Bias
DB DC ON (L) 24VDC	Switches Developer Bias DC voltage
DB AC ON (L) 24VDC	Switches Developer Bias AC voltage
BCR DC CONT	Analog control signal for the DC component of the Bias Charge Roll
BCR ON (L) 24VDC	Switches to the Bias Charge Roll voltage
BCR	Bias Charge Roll voltage (AC & DC)
DB	Developer Bias voltage (AC & DC)
1ST BTR	First Bias Transfer Roll voltage (DC)
2ND BTR	Second Bias Transfer Roll voltage (DC)
DTS	Detack Saw voltage (AC)

**BD4 MCU PWB↔Used Cartridge Sensor↔Cartridge Sensor↔Rotary Sensor↔Developer Clutch↔Developer Fan↔Dispense Motor**

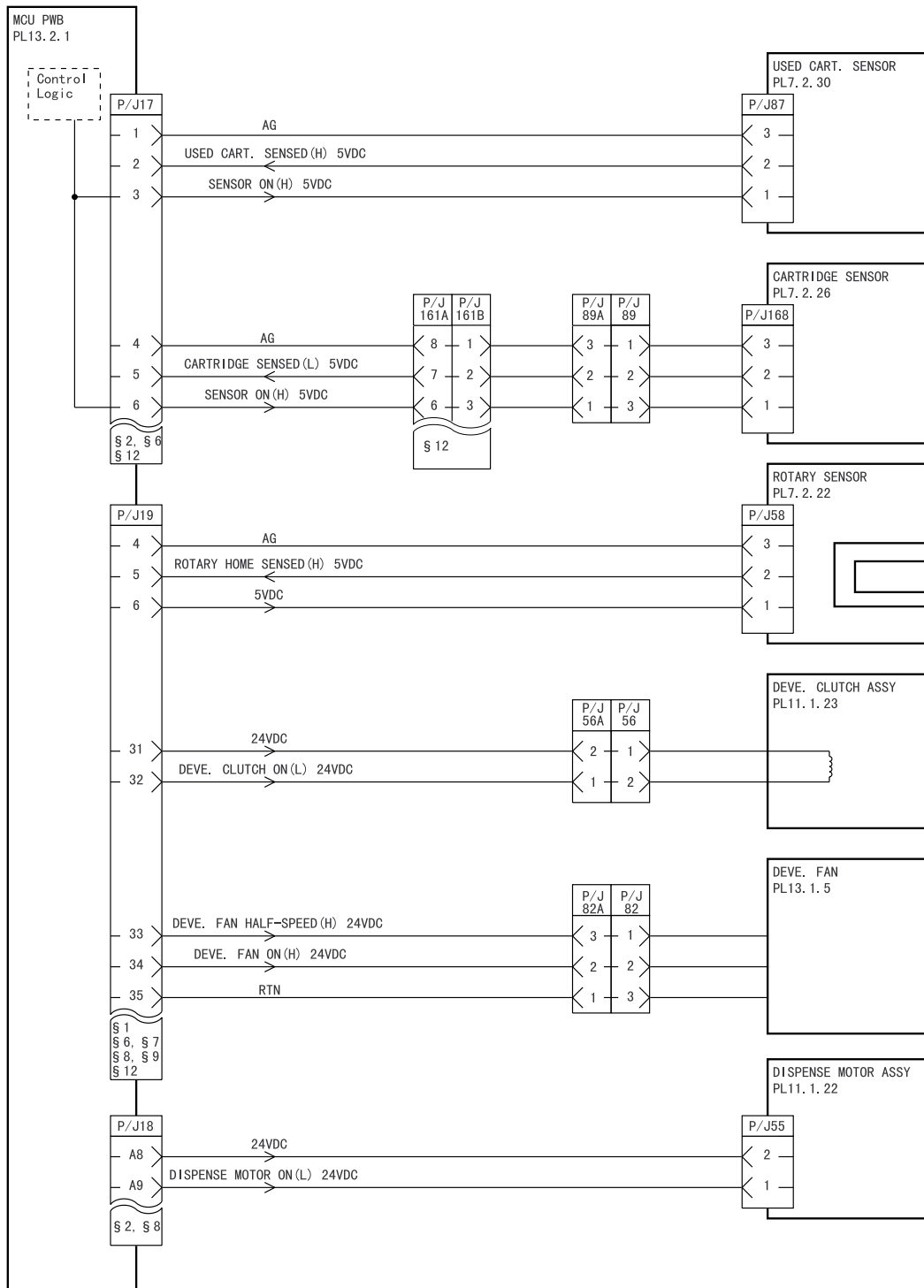

RS1404XB

RS1404XB

**BD4 MCU PWB↔Used Cartridge Sensor↔Cartridge Sensor↔Rotary Sensor↔Developer Clutch↔Developer Fan↔Dispense Motor**

The following table shows the signal names for this BD:

Signal Name	Description
USED CARTRIDGE SENSED (H) 5VDC	Monitors the status of the Toner Cartridge. Low=New cartridge. High=Used cartridge
SENSOR ON (H) 5VDC	LED power to the Cartridge Sensor. Low=Off. High=On
CARTRIDGE SENSED (L) 5VDC	Monitors presence of Toner Cartridge. Low=In place. High=Not in place
ROTARY HOME SENSED (H) 5VDC	Monitors the position of the Rotary Frame Assembly. Low=Off home. High=Home
DEVELOPER CLUTCH ON (L) 24VDC	Switches the Developer Clutch. Low=On. High=Off
DEVELOPER FAN ON (H) 24VDC	Switches the Developer Fan speed between fast and slow
DEVELOPER FAN HALF SPEED ON (H) 24VDC	Switches the speed of the Developer Fan. Low=Off. High=On
DISPENSE MOTOR ON (L) 24VDC	Switches the Dispense Motor. Low=On. High=Off

**BD5 MCU PWB & LVPS↔Rotary Motor PWB↔Rotary Motor**

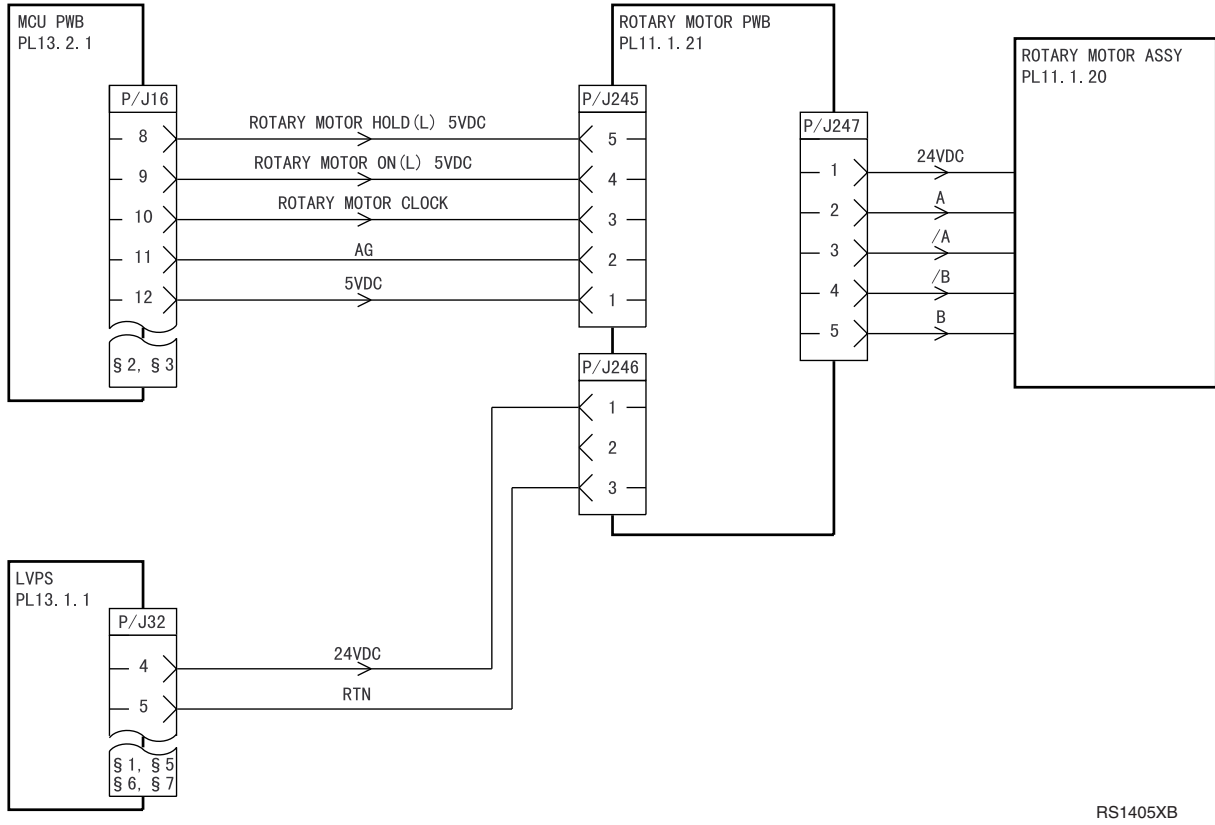

RS1405XB

**BD5 MCU PWB & LVPS↔Rotary Motor PWB↔Rotary Motor**

The following table shows the signal names for this BD:

Signal Name	Description
ROTARY MOTOR ON (L) 5VDC	Switches the Rotary Motor. Low=On. High=Off
ROTARY MOTOR HOLD (L) 5VDC	Controls the Rotary Motor hold current
ROTARY MOTOR CLOCK	Clock signal for the Rotary Motor
A, /A, B, /B	Rotary Motor phase signals

**BD6 MCU PWB ↔ BTR Cam Solenoid ↔ TR0 Sensor ↔ Paper Handling Motor Assembly ↔ Process Motor Assembly**

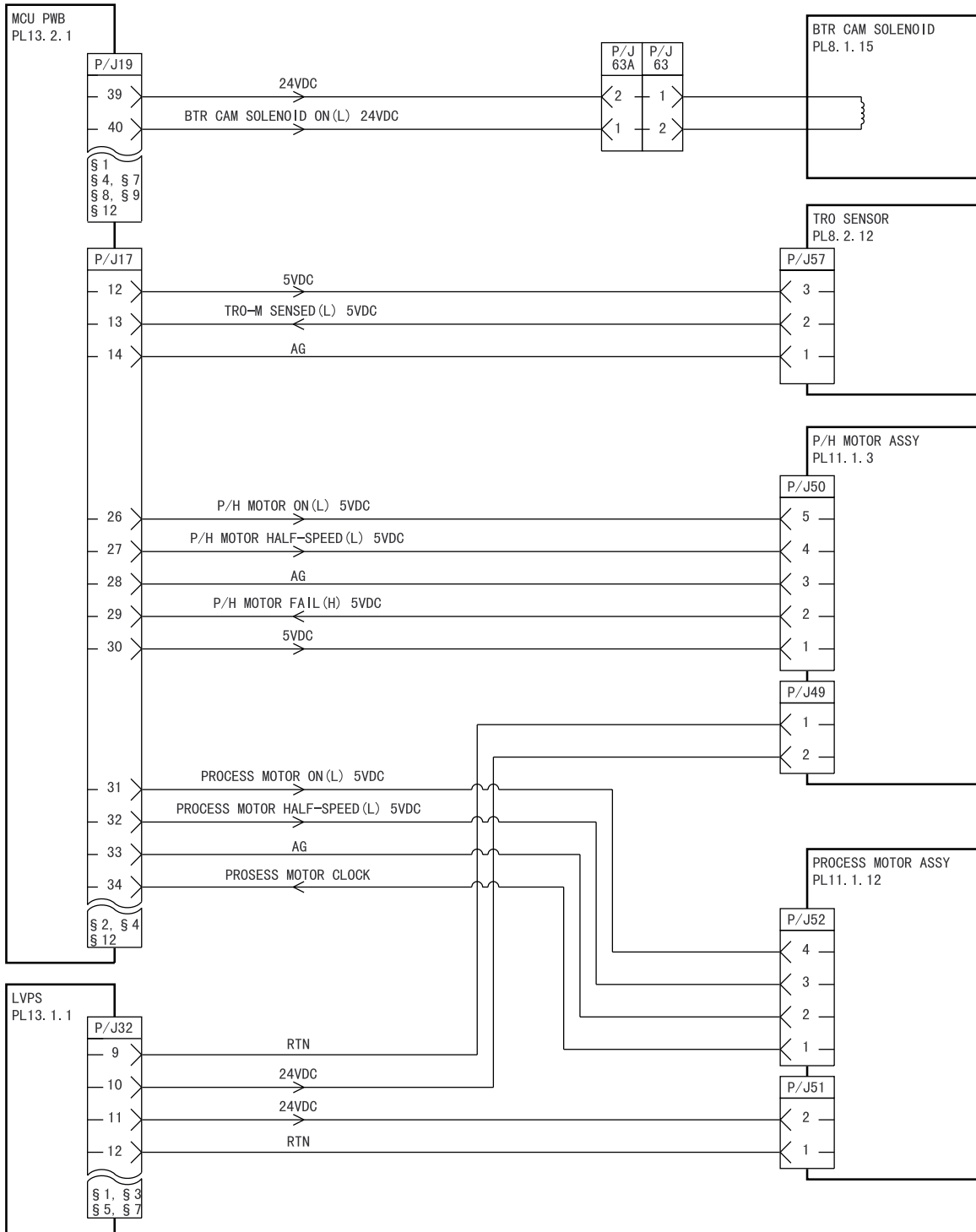

RS1406XB

RS1406XB



**BD6 MCU PWB↔BTR Cam Solenoid↔TR0 Sensor↔Paper Handling Motor Assembly↔Process Motor Assembly**

The following table shows the signal names for this BD:

Signal Name	Description
BTR CAM SOLENOID ON (L) 24VDC	Switches the BTR Cam Solenoid. Low=On. High=Off
TR0-M SENSED (L) 5VDC	Monitors the position of the timing marks on the IBT Belt. Low=On. High=Off
P/H MOTOR ON (L) 5VDC	Switches the Paper Handling Motor. Low=On. High=Off
P/H MOTOR HALF-SPEED (L) 5VDC	Switches the Paper Handling Motor speed. Low=Half speed. High=Normal speed
P/H MOTOR FAIL (H) 5VDC	Signal indicating a problem with the Paper Handling Motor. Low=Normal. High=Motor failure
PROCESS MOTOR ON (L) 5VDC	Switches the Process Motor. Low=On. High=Off
PROCESS MOTOR HALF-SPEED (L) 5VDC	Switches the Process Motor speed. Low=Half speed. High=Normal speed
PROCESS MOTOR CLOCK	Process Motor clock signal

**BD7 MCU PWB↔LVPS↔Fuser Assy↔Oil Roll Assy**

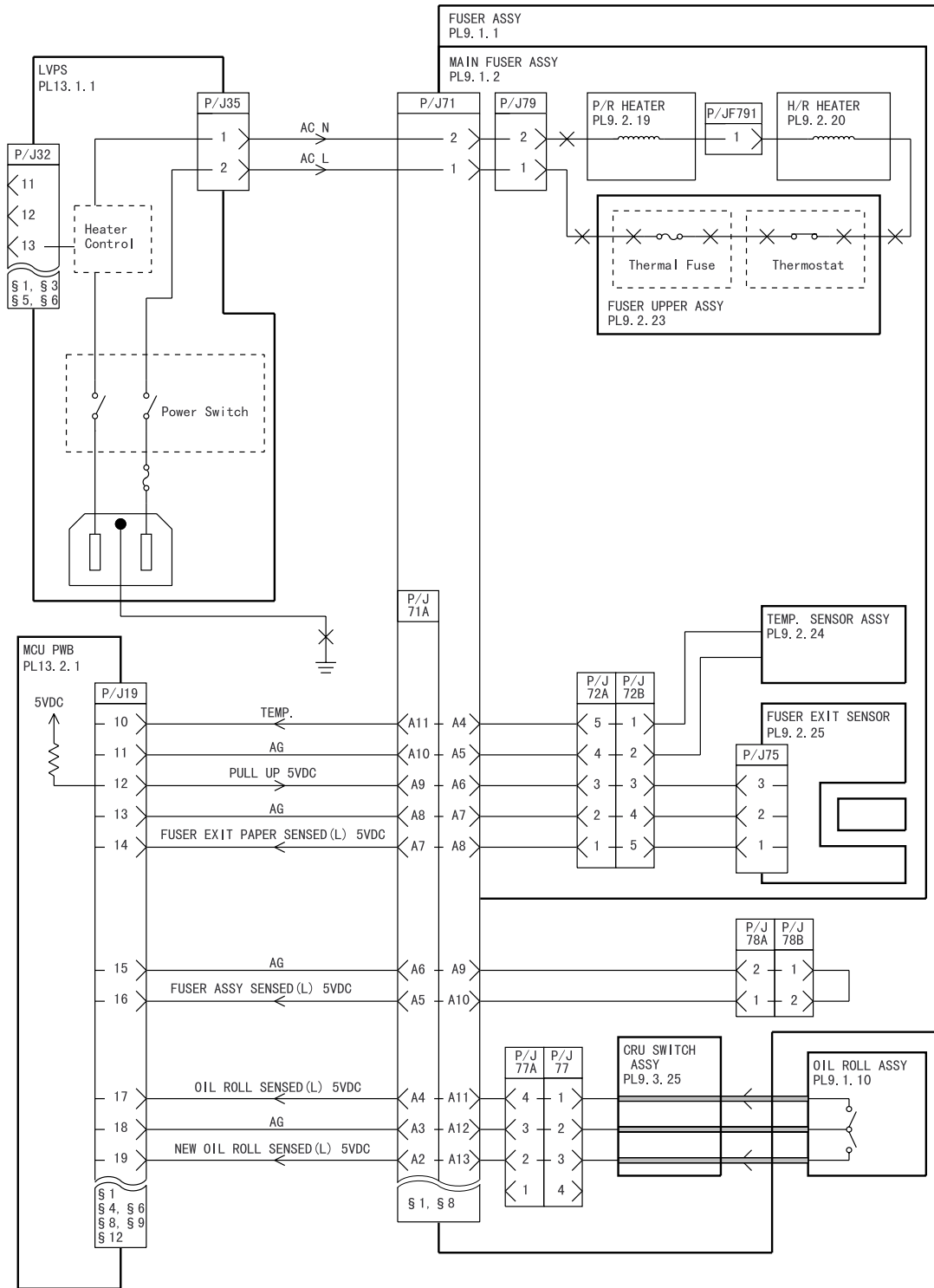

RS1407XB

RS1407XB

**BD7 MCU PWB↔LVPS↔Fuser Assembly↔Oil Roll Assembly**

The following table shows the signal names for this BD:

Signal Name	Description
AC L	AC Hot for the Heat Rods
AC N	AC Neutral for the Heat Rods
TEMP	Analog signal from the Fuser Temperature Sensor
FUSER EXIT PAPER SENSED (L) 5VDC	Signal from the Fuser Exit Sensor. Low=Actuated. High=Not actuated
FUSER ASSEMBLY SENSED (L) 5VDC	Monitors the position of the Fuser Assembly. Low=Fuser in position. High=Fuser not in position
OIL ROLL SENSED (L) 5VDC	Monitors the presence of the Oil Roll. Low=Oil Roll in position. High=Oil Roll not in position
NEW OIL ROLL SENSED (L) 5VDC	At power on, monitors the state of the Oil Roll. Low=New. High=Old

**BD8 MCU PWB↔Fuser Tray Assembly↔Environment Sensor**

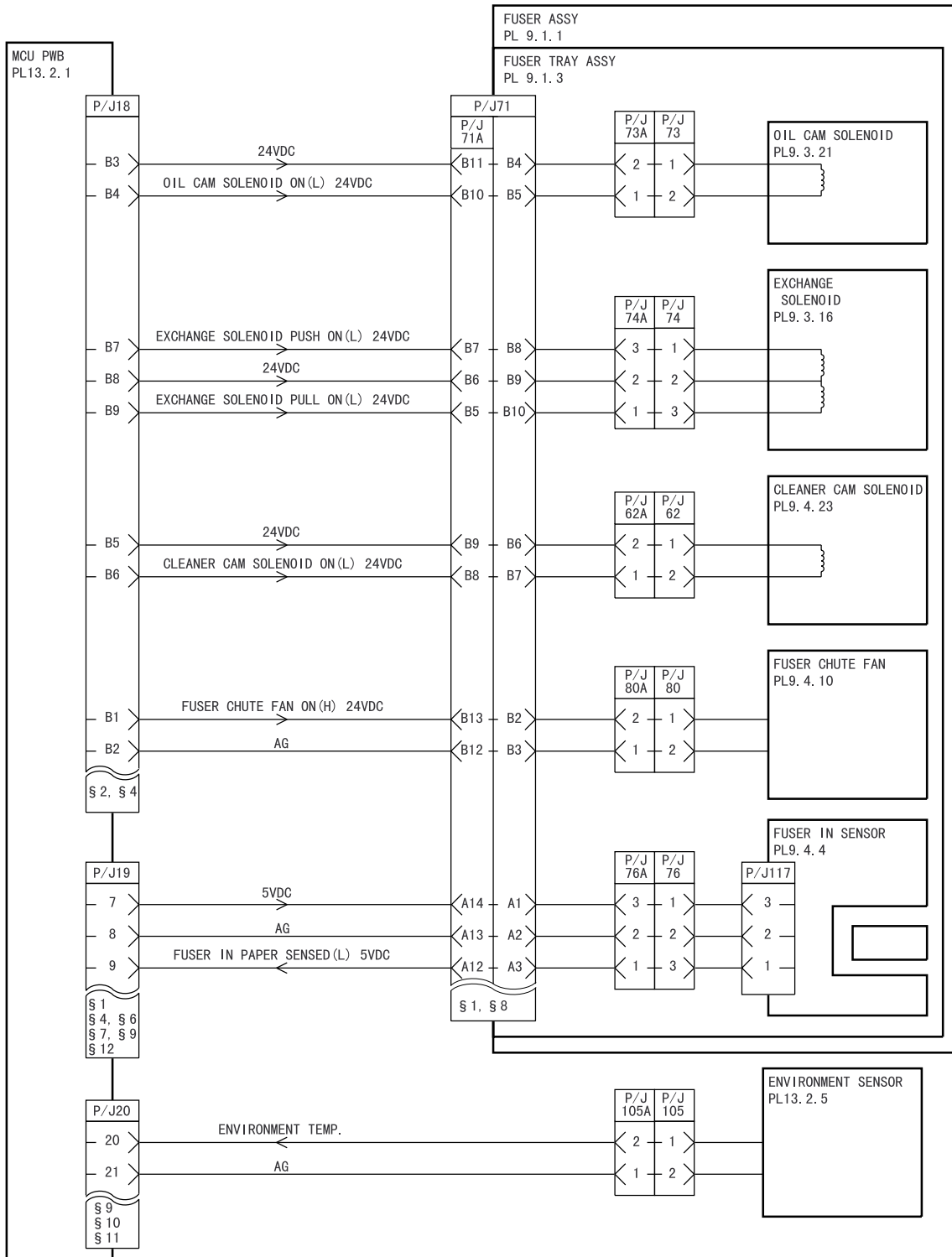

RS1408XB

RS1408XB

**BD8 MCU PWB↔Fuser Tray Assembly↔Environment Sensor**

The following table shows the signal names for this BD:

Signal Name	Description
OIL CAM SOLENOID ON (L) 24VDC	Switches the Oil Cam Solenoid. Low=On. High=Off
CLEANER CAM SOLENOID ON (L) 24VDC	Switches the Cleaner Cam Solenoid. Low=On. High=Off
EXCHANGE SOLENOID PUSH ON (L) 24VDC	Switches the Exchange Solenoid so paper exits to Face Down Tray.
EXCHANGE SOLENOID PULL ON (L) 24VDC	Switches the Exchange Solenoid so paper exits to Face Up Tray.
FUSER CHUTE FAN ON (H) 24VDC	Switches the Fuser Chute Fan. Low=Off. High=On
FUSER IN PAPER SENSED (L) 5VDC	Signal from the Fuser Entrance Sensor. Low=Actuated. High=Not actuated
ENVIRONMENT TEMP	Analog signal from the Environment Sensor

**BD9 MCU PWB ↔ Size Switch Assembly ↔ Feed Solenoid ↔ No Paper Sensor ↔ Low Paper Sensor**

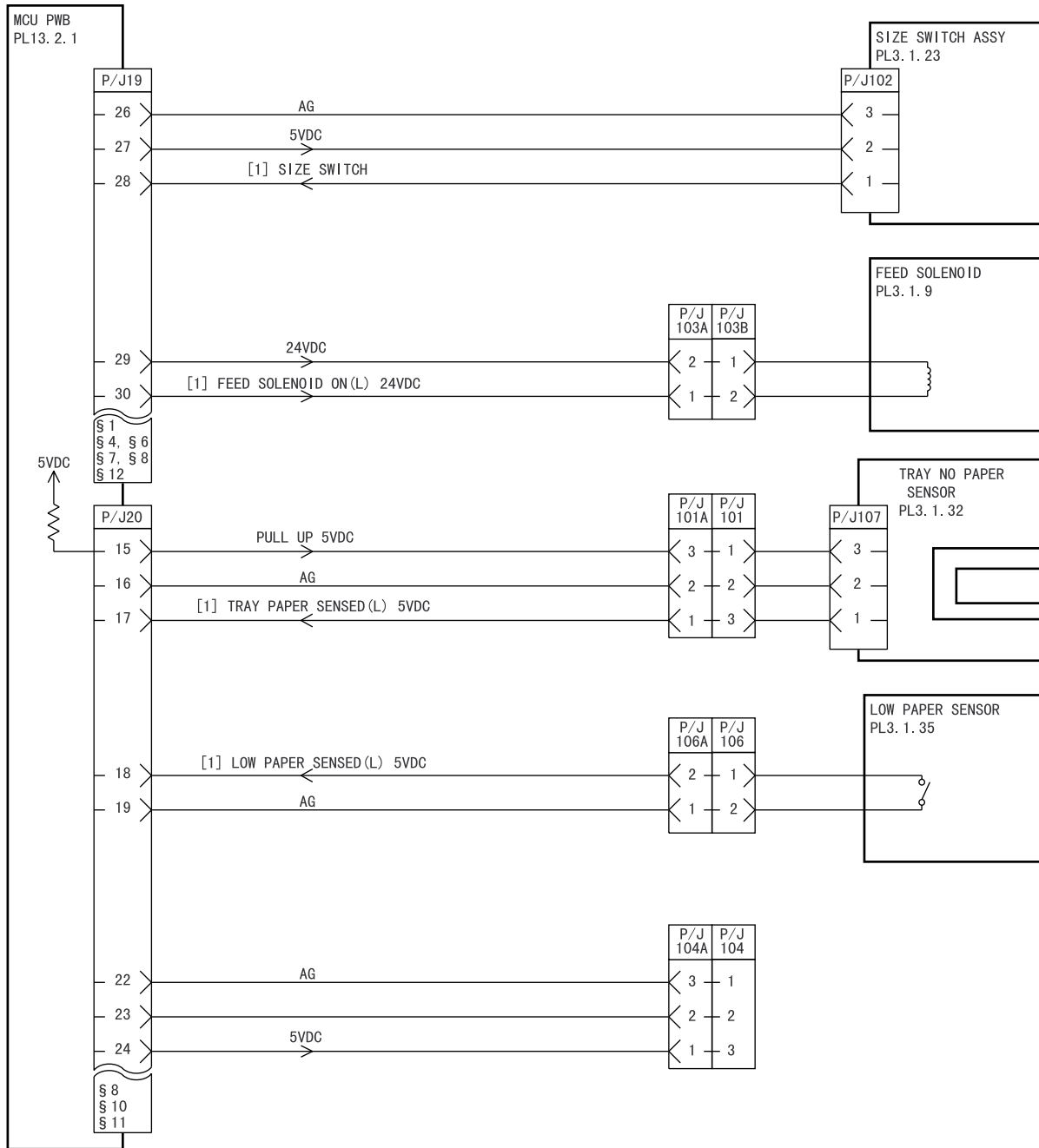

RS1409XB

**BD9 MCU PWB↔Size Switch Assembly↔Feed Solenoid↔No Paper Sensor↔Low Paper Sensor**

The following table shows the signal names for this BD:

Signal Name	Description
[1] SIZE SWITCH	Analog signal from the Tray 1 Size Sensor.
[1] FEED SOLENOID ON (L) 24VDC	Switches the Tray 1 Feed Solenoid. Low=Feed. High=No feed
[1] TRAY PAPER SENSED (L) 5VDC	Monitors paper level in Tray 1. Low=Paper present. High=Paper not present
[1] LOW PAPER SENSED (L) 5VDC	Signal from the Tray 1 Low Paper Sensor. Low=Low paper level. High=Normal paper level

**BD10 MCU PWB↔Main P/H Assembly**

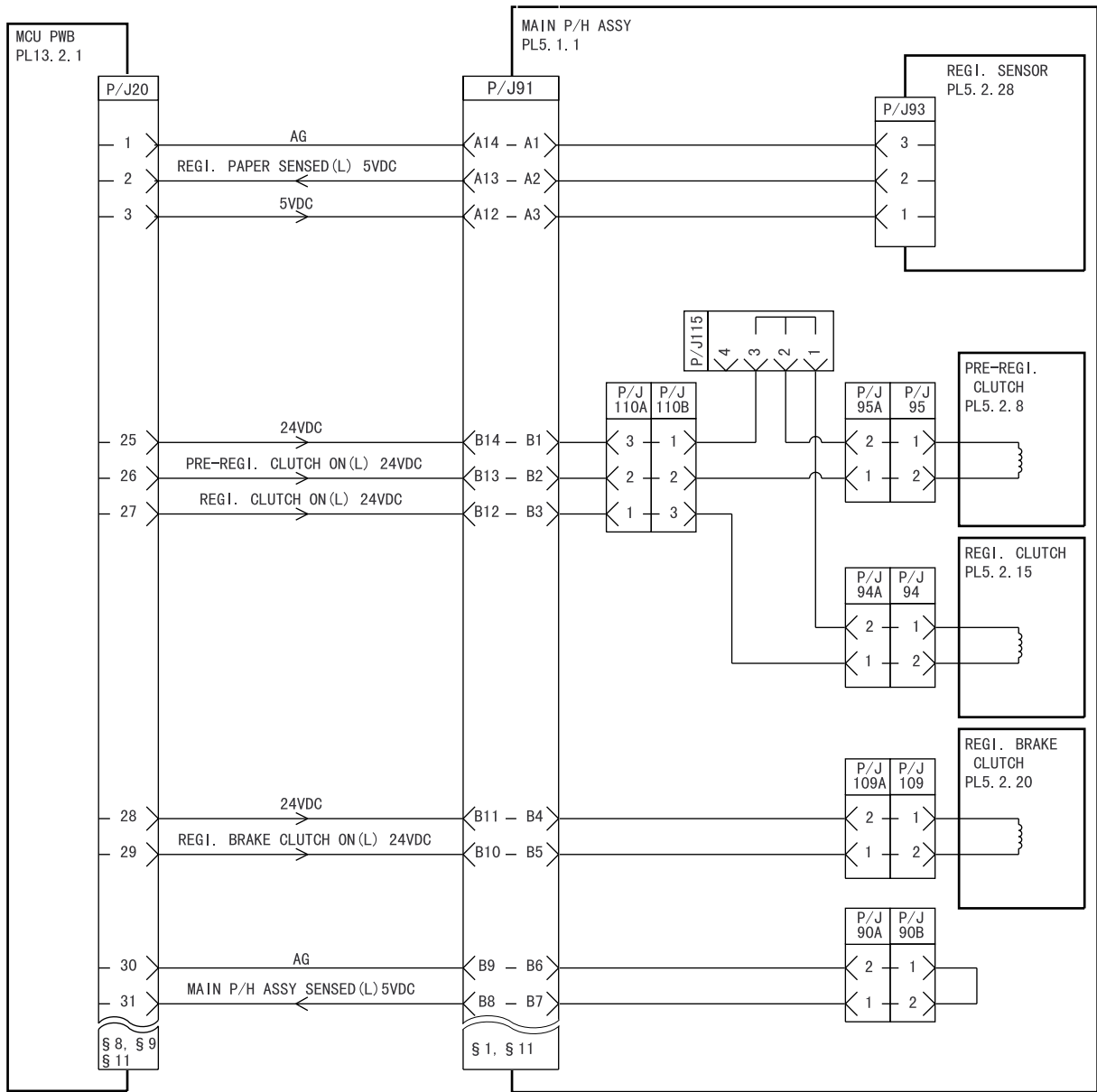

RS1410XC

RS1410XC



**BD10 MCU PWB↔Main P/H Assembly**

The following table shows the signal names for this BD:

Signal Name	Description
REGISTRATION PAPER SENSED (L) 5VDC	Monitors paper at the Registration Sensor. Low=Paper present. High=Paper not present
PRE-REGISTRATION CLUTCH ON (L) 24VDC	Switches the Pre-Registration Clutch. Low=On. High=Off
REGISTRATION CLUTCH ON (L) 24VDC	Switches the Registration Clutch. Low=On. High=Off
REGISTRATION BRAKE CLUTCH ON (L) 24VDC	Switches the Registration Brake Clutch. Low=On. High=Off
MAIN P/H ASSEMBLY SENSED (L) 5VDC	Monitors the position of the Main Paper Tray. Low=Tray in position. High=Tray not in position

**BD11 MCU PWB ↔ Main Paper Handling Assembly ↔ MSI Assembly**

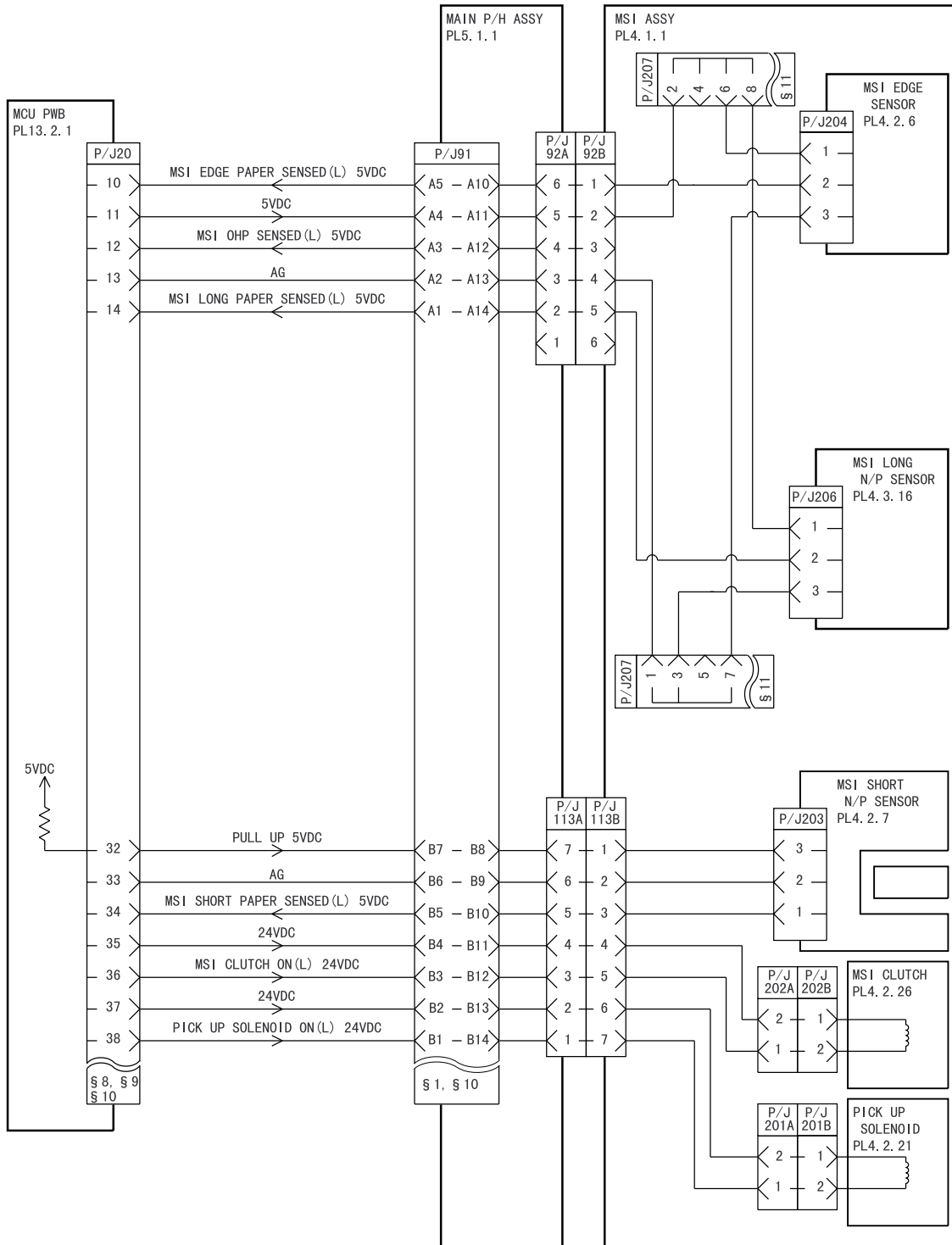

RS1411XC

RS1411XC

**BD11 MCU PWB↔Main Paper Handling Assembly↔MSI Assembly**

The following table shows the signal names for this BD:

Signal Name	Description
MSI EDGE PAPER SENSED (L) 5VDC	Monitors paper in the MSI. Low=Paper present. High=Paper not present
MSI SHORT PAPER SENSED (L) 5VDC	Monitors short paper in the MSI. Low=Paper present. High=Paper not present
MSI LONG PAPER SENSED (L) 5VDC	Monitors the presence of paper longer than 150mm in the MSI. Low=Long paper present. High=Long paper not present
MSI CLUTCH ON (L) 24VDC	Switches the MSI Feed Clutch. Low=On. High=Off
PICK UP SOLENOID ON (L) 24VDC	Switches the MSI Pick Up Solenoid. Low=On. High=Off

**BD12 MCU PWB ↔ Top Exit Sensor ↔ Exit Chute Switch ↔ Full Stack Sensor ↔ Fuser Fan**

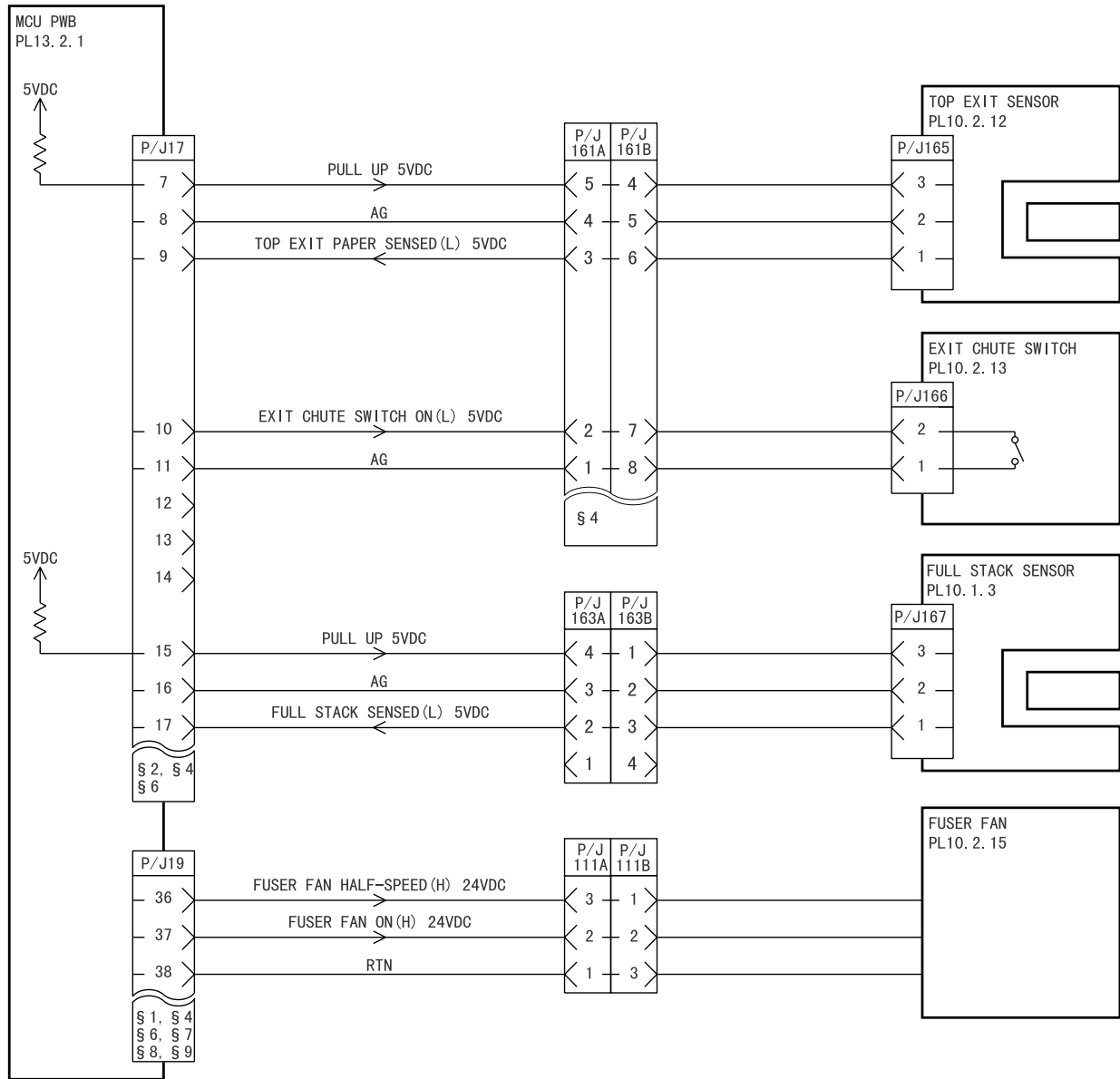

RS1412XB

**BD12 MCU PWB↔Top Exit Sensor↔Exit Chute Switch↔Full Stack Sensor↔Fuser Fan**

The following table shows the signal names for this BD:

Signal Name	Description
TOP EXIT PAPER SENSED (L) 5VDC	Monitors paper at the Top Exit Sensor. Low=Paper present. High=Paper not present
EXIT CHUTE SWITCH ON (L) 5VDC	Monitors position of Upper Exit Assembly. Low=Assembly closed. High=Assembly open
FULL STACK SENSED (L) 5VDC	Monitors the paper level in the Face Down Tray. Low=Tray full. High=Tray not full
FUSER FAN HALF-SPEED (H) 24VDC	Switches the Fuser Fan speed. Low=Normal speed. High=Half speed
FUSER FAN ON (H) 24VDC	Switches the Fuser Fan. Low=Off. High=On

**BD13 MCU PWB ↔ Controller PWB ↔ Operation Panel ↔ Controller Fan**

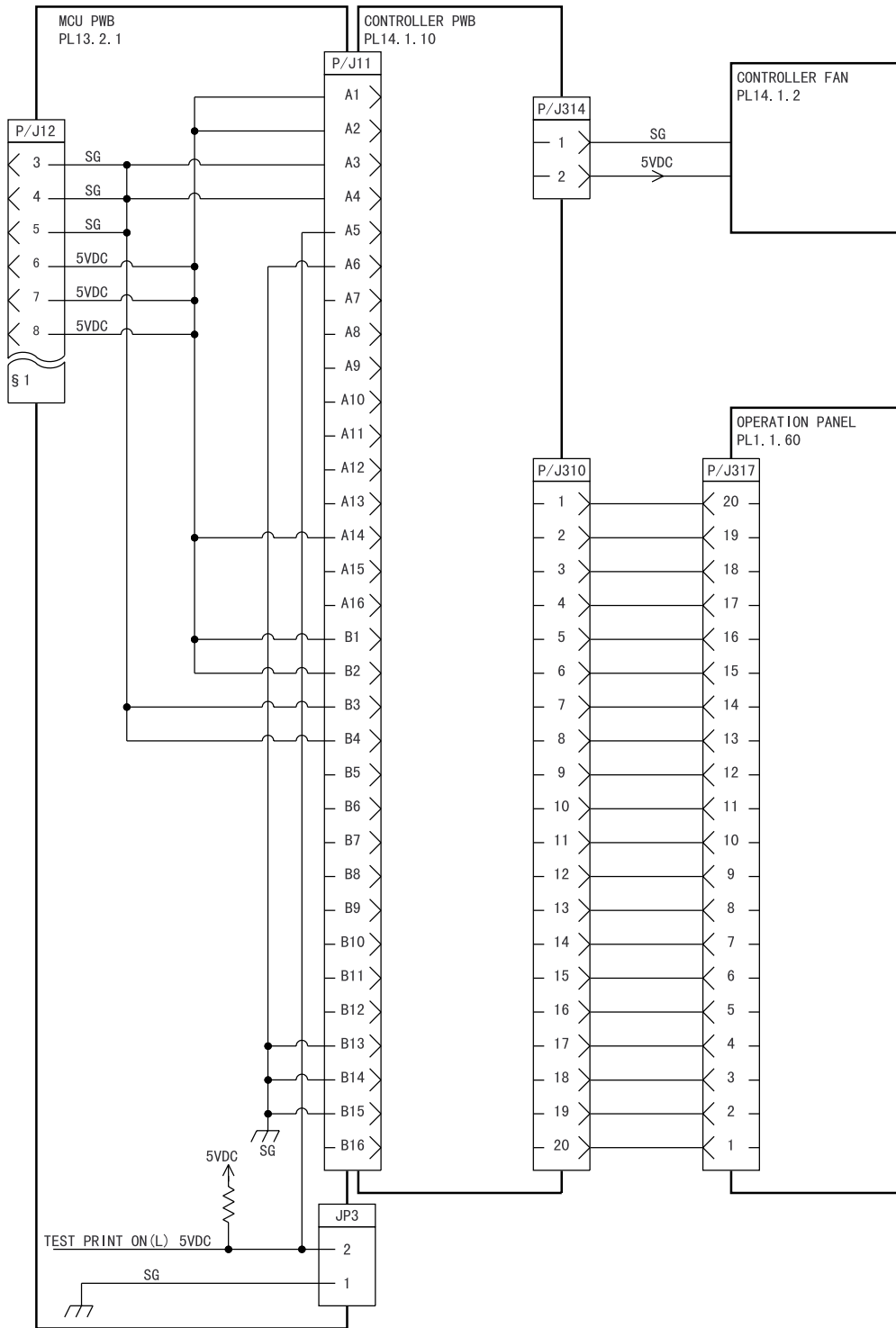

RS1413XB

**BD13 MCU PWB↔Controller PWB↔Operation Panel↔Controller Fan**

The following table shows the signal names for this BD:

Signal Name	Description
TEST PRINT ON (L) 5VDC	Signals the MCU PWB to generate a Test Print. Low=Generate a Test Print. High=Do not generate a Test Print

Blank Page



## **Section 13 - Printer Specifications**

## **Contents**

---

General Specifications .....	13-3
Speeds for Continuous Printing After the First Sheet Out .....	13-6
Image Resolution and Reproduction Tolerances .....	13-7
Paper Input Devices .....	13-8
Paper Output Devices .....	13-8

## General Specifications

Category	Specification
Standard configuration	Print Engine with Upper Tray (250 sheet), MSI (150 sheet), and Face Up Tray
Printing method	Xerography with two transfer processes
Exposure method	Data modulated (off/on) laser beam scanning
Laser specifications	Class 3B, 5milliwatt semiconductor laser diode
Resolution of printed image	600 dpi (dots per inch)
Development method	Dry toner and carrier mixture
Fusing method	Heat and pressure, with silicone oil lubricant
Black and White Printing Mode	16ppm. Monochrome using a single image that is made up of black toner
Four Color Mode	4ppm. Four color process using separate yellow, magenta, cyan, and black toner images
Warm-up time	From either a cold start or from deep sleep mode (with an ambient temperature of 22°C and relative humidity of 55%) to Ready to Print within five minutes
Power supply requirements	<b>110V printer</b> 100 VAC (±10%) @ 50/60 Hz (±3 Hz) <b>120V printer</b> 120 VAC (±10%) @ 50/60 Hz (±3 Hz) <b>240V printer</b> 220/240 VAC (±10%) @ 50/60 Hz (±3 Hz)
Power supplied to the Controller PWB	5VDC @ 6.0A
Power consumption and input current of the IOT during a print cycle. These figures do not take into account the power consumption of the Controller PWB.	<b>During Print Cycle:</b> 100VAC: 1100 watts or less 120VAC: 1100 watts or less 240VAC: 1100 watts or less <b>At Ready:</b> 100VAC: 1000 watts or less with Fuser on. 100 watts or less with Fuser off. 120VAC: 1000 watts or less with Fuser on. 100 watts or less with Fuser off. 240VAC: 1000 watts or less with Fuser on. 100 watts or less with Fuser off. <b>During Light Sleep:</b> 100VAC: 1000 watts or less with Fuser on. 100 watts or less with Fuser off. 120VAC: 1000 watts or less with Fuser on. 100 watts or less with Fuser off. 240VAC: 1000 watts or less with Fuser on. 100 watts or less with Fuser off. <b>During Deep Sleep:</b> 100VAC: 20 watts or less 120VAC: 20 watts or less 240VAC: 20 watts or less

**General Specifications continued**

Category	Specification
Size and weight of base engine with the MSI Tray retracted. Not including the Xerographic Cartridge, Waste Toner Box, Toner Cartridges, Oil Roll Controller PWB.	Height: 490mm $\pm$ 1% Width: 728mm $\pm$ 1% Depth: 641mm $\pm$ 1% Weight: 69.0kg $\pm$ 1%
Size and weight of Upper Tray	Height: 95mm $\pm$ 1% Width: 560mm $\pm$ 1% Depth: 547mm $\pm$ 1% Weight: 2.8kg $\pm$ 1%
Size and weight of the Xerographic Cartridge, including the Waste Toner Box	Height: 181mm $\pm$ 1% Width: 213mm $\pm$ 1% Depth: 510mm $\pm$ 1% Weight: 2.4kg $\pm$ 1%
Size and weight of the Waste Toner Box	Height: 131mm $\pm$ 1% Width: 875.5mm $\pm$ 1% Depth: 444mm $\pm$ 1% Weight: 0.45kg $\pm$ 1%
Size and weight of each of the four Toner Cartridges	Height: 54.5mm $\pm$ 1% Width: 50mm $\pm$ 1% Depth: 400mm $\pm$ 1% Weight: 0.35kg $\pm$ 1%
Size and weight of the Oil Roll Assembly	Height: 50mm $\pm$ 1% Width: 75mm $\pm$ 1% Depth: 430mm $\pm$ 1% Weight: 1.0kg $\pm$ 1%
Minimum space requirements; measured from the printer covers to the wall	Front: 835mm Back: 150mm Right: 551mm Left: 503mm Top: 400mm
Operating environment needed for normal operation	5~32°C @ 15~85% RH (no condensation) 0~2500m No direct sunlight (less than 3,000 LUX)
Operating environment needed for best print quality	10~32°C @ 15~85% RH (no condensation) 0~2500m No direct sunlight (less than 3,000 LUX)
Maximum paper size	Upper Tray: 12 x 13 inch Oversize Tray: 13 x 18 inch MSI: 3.5~13 inch x 5.5~19 inch
Maximum printable area	12.6 inch x 18 inch. Print quality may deteriorate within a 4mm margin around the sheet of paper
Best print quality printable area	11.7 inch x 17 inch.

**General Specifications continued**

Category	Specification
Maximum paper tray capacity	Upper Tray: 250 sheets standard paper (28mm maximum stack height).  Oversize Tray: 250 sheets standard paper (28mm maximum stack height).  MSI: 150 sheets standard paper (16mm maximum stack height). 25 ~ 75 sheets of standard transparencies 75 sheets of standard labels 75 postcards 20 envelopes
Paper types supported	Refer to the Qms Magicolor 330 User Manual
Maximum output tray capacity	Face Down Tray: 250 sheets standard paper Face Up Tray: 150 sheets if smaller than A4, to Letter size 50 sheets if larger than Letter size
Maximum noise generated	While printing: 54.8 db Impulse noise while running: 63.3 db Ready: 38.3 db Impulse noise in Ready: 38.3 db Light Sleep: 38.3 db Deep Sleep: 35.0 db
Average life expectancy of customer replaceable consumables. Assuming: 5% image coverage Image ratio of 50% B/W and 50% color 4 prints per job	Xerographic Cartridge - - - - - 50K B/W, 20K color Waste Toner Box - - - - - 20K sheets of paper Oil Roll Assembly - - - - - 20K sheets of paper Black Toner Cartridge - - - - - 4.5K images Yellow Toner Cartridge - - - - - 6K images Magenta Toner Cartridge - - - - - 5.7K images Cyan Toner Cartridge - - - - - 6K images
Field replaceable parts with finite life	Main Fuser Assembly - - - - - 250K images or 19.5 hours of toner dispense time Belt Cleaner Assembly - - - - - 180K sheets of paper processed 2ND BTR Assembly - - - - - 100K images processed
General safety standards observed	100/120VAC - UL1950 2nd edition. CSA C22.2 No. 950-M89 220/240VAC - IEC950 2nd edition - 199 by VDE with GS-mark
Laser safety standards observed	100/120VAC - FDA 21 CFR Chapter 1, Subchapter J, Sections 1010 & 1040 220/240VAC - IEC825 Class 1 Laser Product
EMI standards observed	100VAC - VCCI Type 2 Information Processing Devices 100/120VAC - FCC Part 15 Subpart B, Class B (ANSI C63.4/11.4D) 220/240VAC - EN55022 (CISPR Publication 22), Class B EN61000-3-2 (Harmonics) EN61000-3-3 (Flicker)

### Speeds for Continuous Printing After the First Sheet Out

Paper Speed	Color Mode	1Up Transfer	2Up Transfer
Standard (70.5mm per second)	B/W	8+ pages a minute	16+ pages a minute
Half (35.3mm per second)	B/W	1.3+ pages a minute	2.7+ pages a minute
Standard (70.5mm per second)	4 Color	2+ pages a minute	4+ pages a minute
Half (35.3mm per second)	4 Color	0.9+ pages a minute	0.9+ pages a minute

Different print media have different fusing requirements. To ensure the that transferred toner image is permanently bonded to a specific media, printer logic adjusts paper path speed to either slow down or speed up paper travel through the printer. The printer system automatically adjusts speed depending on the type of media that is loaded in the paper trays and by the media related commands sent to the Controller PWB.

Print Media	Color Mode	Speed selected
Standard paper	B/W	Standard (70.5mm per second)
Standard paper	4 Color	Half (35.3mm per second)
Postcards and Envelopes	B/W	Half (35.3mm per second)
Postcards and Envelopes	4 Color	Half (35.3mm per second)
Transparencies	B/W	Standard (70.5mm per second)
Transparencies	4 Color	Half (35.3mm per second)
Label 1	B/W	Half (35.3mm per second)
Label 1	4 Color	Half (35.3mm per second)
Label 2	B/W	Half (35.3mm per second)
Label 2	4 Color	Standard (70.5mm per second)

**Image Registration and Reproduction Tolerances**

Category	Tolerance range
Lead edge registration	Less than $\pm 2.0$ mm
Side edge registration	Less than $\pm 2.5$ mm
Skew (271 mm distance)	Less than $\pm 2.0$ mm
Orthogonality (195 mm distance)	Less than $\pm 1.3$ mm
Parallelism (390 mm distance)	Less than $\pm 2.0$ mm
Straightness in direction of paper travel (390 mm distance)	Less than $\pm 1.0$ mm
Straightness in orthogonal direction of paper travel (271 mm distance)	Less than $\pm 0.7$ mm
Straightness in skew direction of paper travel (383 mm distance)	Less than $\pm 1.5$ mm
Magnification in direction of paper travel (390 mm distance)	Less than $100 \pm 0.8\%$
Magnification in orthogonal direction of paper travel (271 mm distance)	Less than $100 \pm 0.8\%$
Color registration	125 $\mu$ m

## Paper Input Devices

### Optional Large Capacity Input Feeder - Opt1 Tray, Opt2 Tray, and Opt3 Tray

Optional feeder for the Qms Magicolor 330 laser printer. Optional Trays 2, 3, and 4 can each hold up to 250 sheets of B5 to A3, Executive, Letter, and Legal paper.

### MSI (Multipurpose Inserter)

Standard manual feeder for the Qms Magicolor 330 Laser printer. The MSI attaches to the right side of the printer. The MSI holds up to 150 sheets almost any paper from 90mm to 330.2mm wide and from 139.7mm to 457.2mm long.

## Paper Output Devices

### Face Down Tray

Standard output tray for the Qms Magicolor 330 Laser printer. Paper is transported out of the printer face down onto the printer Top Cover. This Tray holds up to 250 sheets of standard paper. The Full Stack Sensor monitors the paper level in the Face Down Tray.

### Face Up Tray

Face Up Tray attaches to the left side of the Qms Magicolor 330 Laser printer. Paper is transported out of the printer face up onto the Face Up Tray. The Tray holds up to 150 sheets of A4, or smaller, to Letter size or 50 sheets of Letter size or larger. There is no Full Stack Sensor on the Face Up Tray.

